



SAFETYQUIP™

The safety professionals!

PRODUCTS & SERVICES



edition 9.1



**Proudly Australian
Owned & Operated**



www.safetyquip.com.au

LOCAL KNOWLEDGE  SAFER WORKERS

Welcome

to SafetyQuip and Edition 9.1 of the
SafetyQuip Products and Services Catalogue.



**Proudly Australian
Owned & Operated**

SafetyQuip is proudly an Australian Owned and Operated Franchise Business with locations around Australia. With over 28 years experience in the Safety and OHS Industry, our Franchise Partners, our customer focused employees and our dedicated National Support Team share the same vision *“To ensure that you and your employees go home safely everyday”*.

SafetyQuip began in 1992 with one location on the Sunshine Coast and a mobile SafetyQuip Van. In 2019, three of our Franchisees purchased the business from the retiring founder. We believe in the philosophy, business and the products and services provided to our customers. Today we have grown to proudly service all of Australia.

We are proud to be a trusted supplier to so many clients around Australia and regard it a privilege to play a role in assisting you to maintain a safe yet productive workplace.

Our section lead-in pages are devoted to providing essential background information on each section topic. Take some time to read them as we are sure they will supplement your OH&S knowledge.

SafetyQuip consistently invests in the training of our team members to ensure that we live up to being *‘The Safety Professionals’*.

SafetyQuip Customer Service Team Members undergo an intensive training program as part of our onboarding process. It assures us and you, that when you purchase from SafetyQuip you get much more than just a product in a box. The quality, service, advice and ongoing support we provide are critical components to our ongoing relationship with you and your business.

Our Safety Centres and Safety Vans – *“The Store that Comes to You”* are a winning combination that has serviced tens of thousands of our valued clients around Australia.

Finally, to all our valued clients around Australia, we thank you for your loyal support over the years. Without you, our vision would not have become what it is today.

Mark Bartlett
Director

Hennie du Plessis
Director

Tim Lewis
Director





<i>SafetyQuip Capabilities</i>	2
<i>A Trusted Safety Supplier</i>	3
<i>A Safe Place To Work</i>	4
<i>Head Protection</i>	5
<i>Eye & Face Protection</i>	11
<i>Hearing Protection</i>	19
<i>Respiratory Protection</i>	27
<i>Workwear</i>	39
<i>Protective Clothing</i>	55
<i>Safety Footwear</i>	67
<i>Hand Protection</i>	77
<i>Height Safety</i>	89
<i>Health & Hygiene</i>	101
<i>Site Safety</i>	111
<i>Product Index</i>	141
<i>Risk Index</i>	143
<i>Corporate Citizenship</i>	145
<i>Store Locations</i>	146



SafetyQuip Capabilities

SALES AND SUPPLY

Pay no more (and often much less) for a range that includes all the top brands. New product demos, expert advice on tap and research for those special needs make SafetyQuip the one-stop shop for safety equipment and PPE compliance. Instant supply, invoicing and back ordering all right there on the spot – and it's all available now!

SafetyQuip is the local face of WHS. Local people who know your workplace and its needs, anchored by a national network with excellent supplier relationships, great IT, centralised tech support and proven business systems.

It's the kind of care and attention you only get when you're dealing with people who own and manage the business.



MOBILE

At whatever interval makes sense, a SafetyQuip Mobile Safety Shop will arrive at your doorstep carrying all your Safety and PPE needs.

All SafetyQuip Mobile Safety Shops are stocked with a broad range of PPE, Footwear and Site Safety Products, this is what makes us different from the rest.

You may choose to receive a scheduled visit and have your Safety needs supplied on the spot or have your special requirements responded to as and when they are needed – such as Workwear Fit outs, Replenishment of PPE Lockers or inspection of Spill Control Kits to name just a few of the ways SafetyQuip can service your business.

There are many ways our Mobile Safety Shops and fully trained Safety Professionals can assist you to stay on top of your Workplace Health and Safety requirements and keep your workplace safe!

SafetyQuip Mobile Safety Shop – The Store that comes to You.

IN STORE / DISTRIBUTION

Should you need to call into our SafetyQuip Safety Shop, our Safety Professionals are here to help.

SafetyQuip trained Customer Service team are able to assist with product choice and selection and provide advice on the use and maintenance of the Safety products you require.

SafetyQuip Safety Shops also act as the service centre for our customers who place orders via phone, website and email. We ensure that your order is processed by Customer Service staff who have experience and knowledge of the products.

Getting your order correct and quickly delivered to you is our top priority.

Efficient over the counter assistance and prompt deliveries are all part of the SafetyQuip service.

ONLINE

SafetyQuip's online ordering option gives you full access to the complete range of personal protective equipment and site safety products.

From simply being able to browse the electronic catalogue right through to ordering the products you need, the SafetyQuip website is there to make life easy.

If you do not currently have an account with SafetyQuip, but are a regular purchaser of our products, you might like to contact your nearest SafetyQuip branch to discuss if opening an online account is the right option for you.

Our website also has some valuable workplace health and safety resources including references guides, videos and technical brochures to assist you further.

Huge range, top brands and reliable advice!



A Trusted Safety Supplier

What makes us credible?

SafetyQuip is an established part of the Industrial Safety Market with over 25 years of experience and knowledge, and counting. Our national network interacts with a broad range of industries and enables us to service multi-state customers with consistency and reliability. Customers have come to rely on the dependability and stability that the SafetyQuip business model offers.

SafetyQuip's unique combination of fulfilment options ensures that it has an edge in responsiveness and customer service that is widely valued and hard to beat in a market often devoid of the personal touch.

We understand that as a supplier of Personal Protective Equipment, Workwear and Site Safety Products, our customers depend on the advice, products and support services that we provide to enable them to meet their duty of care when implementing Risk Control Measures involving a PPE solution.



At SafetyQuip we work hard to deliver on our core premise of 'Local Knowledge - Safer Workers'. To ensure our national network executes effectively across all channels, we have in place a range of business support processes and procedures that provide our customers with the assurances that they are dealing with a credible supplier.

Here's a few of the Safety things that we think are important as a **SPECIALIST SAFETY SUPPLIER**:

- Standards are important, that's why at SafetyQuip we only supply products that meet Australian Standards or a relevant International Standard
- Our internal Learning Management System provides in-house Safety Training Modules for all levels of the SafetyQuip Team.
- We heavily focus on integrated Supplier Training with nationally selected Suppliers.
- When it comes to the selection, use and maintenance of Safety products, our customers have our full attention.
- Our Duty of Care to our customers will always come first

Full Scope Safety Professionals

SafetyQuip offers customers a full scope safety solution that covers workplace needs from head to toe and includes industrial safety & environmental requirements.

Leveraging well established long term supplier relationships, SafetyQuip offers a comprehensive range of leading brands to assist in selecting the best value 'fit-for-purpose' product solutions for all applications.

In conjunction with our nationally selected suppliers additional product support is offered via a range of services including:

- **Respirator fit testing**
- **Hearing fit testing**
- **Height Safety equipment inspection**
- **Spill control replenishment**
- **Signage surveys**
- **Workwear & footwear services**

Your local SafetyQuip store can discuss any needs you may have and provide the most effective and economical solution.

Our local knowledge and staff training enables our sales people to advise customers on correct product choices so that the intended level of protection is achieved.

Compliance

With thousands of lines available, the backup of a national network and service provided by local people who are trained to assist in solving your workplace safety issues, compliance becomes less of a problem.

In fact, if you are worried about Compliance - just ask. Anything we can't answer, our National Support Team can. Or we can organise for economical OH&S Support to be provided by certified specialists.

The SafetyQuip catalogue also provides some useful 'Risk Assessment' background information and 'Safety Tips' for each category of PPE. Refer to our 'A Safe Place To Work' page that follows for some important background information.

Why take the risk when SafetyQuip makes compliance easy.





A Safe Place To Work

CODES OF PRACTICE

The National Workplace Health and Safety (WHS) Act and Regulations include Codes of Practice describing workplace duty of care responsibilities. Some Codes of Practice are specific to a particular work risk (refer to www.safeworkaustralia.gov.au).

One code is devoted to the management of workplace risk. Any person conducting a business or a business undertaking (PCBU - described in the Safe Work Australia website) is expected to conduct their responsibilities in a format that ensures every worker has a safe place of work. The National Codes of Practice help you make informed decisions in the assessment of hazards and the application and management of control measures.

MANAGEMENT COMMITMENT

The Code of Practice “How to Manage Health and Safety Risks” now requires a manager to consult with employees on workplace health and safety issues in which they are involved. If workers are represented by a Safety Representative then that representative must be included in the consultation process.



IMPORTANT TERMS

Hazard – A hazard is a work practice that has the potential to cause harm. Ask yourself the most unlikely “what if” questions when observing workplace and work practices. Under present legislation, hazards now include workplace bullying and violence, poor workplace design, inadequate systems controls or the lack of or no procedures of operation.

Risk – Is an assessment of the likelihood that a specific hazard will produce harmful consequences. A risk assessment should determine a time frame in which to apply control measures, e.g. an immediate machine shutdown.

Risk Control – Risk control is normally a two-step process:

- Eliminate the risk as far as reasonably practicable. Eliminating the hazard to eliminate the risk is the highest ideal.
- Put in place reasonable and practicable control measures that produce a downgrading of the hazard to a lower risk category.

CONTROL MEASURES

Selecting appropriate risk control measures can be a difficult task for persons in charge of a business or undertaking (PCBU). It is important you maintain a structured approach to help eliminate or minimise risks identified in your workplace. For the most effective way to control risks, aim to implement higher stages from the table below, before considering the lower stages.

This table explains how each stage should be implemented:

STAGE	HOW TO IMPLEMENT
Stage 1 - Elimination	Remove the risk of exposure to the hazard completely.
Stage 2 - Substitution	Control the risk by substituting it with a less hazardous or non-hazardous alternative.
Stage 3 - Isolation	Reduce the risk by enclosing or isolating it.
Stage 4 - Engineering	Put engineering controls in place to eliminate or reduce the risk.
Stage 5 - Administration	Implement administrative controls to minimise the risk.
Stage 6 - Personal protective equipment (PPE)	Require your workers to wear PPE (e.g. safety goggles, gloves, iridescent vests and safety boots, while in the vicinity of the risk).

CODES OF PRACTICE AND PPE

WH&S legislation specifies that PPE is only to be selected for worker protection when all higher ranking control measures have been investigated and excluded or PPE is selected as a component of a higher ranked control measure. Under WH&S Regulations a person in charge of a workplace must:

- Select the equipment in accordance with any technical standard published by Safe Work Australia e.g. a relevant Code of Practice.
- The PPE put in place to control a risk is maintained, replaced or tested in order to continue to function as a suitable risk control measure. Furthermore there is an expectation that the quality or performance criteria of that PPE is not altered or downgraded throughout the period of use.
- Ensure that all users of PPE are trained in the use, maintenance, function and performance of each item of PPE specific to each job application.
- Demonstrate ongoing supervision in the correct use of PPE, e.g. toolbox talks, in-house audits, safety committee meeting minutes.

HEAD PROTECTION

APPLICATION

The use of helmets will include the need to protect employees from exposure to falling objects, bumps, electrical contact, sun, heat and fire, low light risk and emergency situations.

RISK ASSESSMENT

The need to wear head protection should be established by conducting a risk assessment. Elimination or control of a hazard should be given first consideration. Key factors influencing a head protection risk assessment:

- The nature and location of the work
- Potential of falling objects
- Contact with fixed or protruding objects
- Contact with electrical hazards
- Exposure to heat, sun, wind, rain and chemicals
- The impact on hearing protection by head/face protection accessories
- Specialist fire & emergency rescue situations



The head comfort of workers exposed to **high temperatures/heat** is important. Ventilated, white safety helmets will provide better heat dissipation.

Hard hat reflective strips are available for **low light** working risks. The tape is available in curved and straight strips and coated in a safe and approved adhesive.

Emergency and Warden safety helmets must always have an

adjustable chin strap fitted. All are required to have the approved identification. The safety helmet colours for Emergency Warden positions are:

1. White - Chief Warden
2. White - Deputy Chief Warden
3. White - Communications Officer
4. Yellow - Area or Floor Warden
5. Red - Warden
6. Green - First Aid Officer - White Cross on a Green Square

Accessory options:

- Cap attachable earmuffs
- Face shield or welding shield
- Visor/muff combinations for brushcutting/chainsaw applications
- Wide brim for additional shade in hot climates
- Neck flaps for protection against weather, molten metal splash, hot substances etc.
- Chin straps

HELMET SERVICE LIFE & INSPECTION

Safety helmet shells generally have a working life of **3 years** from the date of issue. Internal headgear should be replaced every 2 years. Safety helmets and components should be inspected weekly for dents, cracks, scratches or other damage that may reduce the degree of safety originally provided. Helmets showing damage or deterioration to the shell should be immediately disposed of.



SAFETY TIPS

- Employees **MUST** be trained in the use and limitations of protective helmets.
- Mark the issue date on the label provided in the helmet.
- Do not place non-approved stickers on, or paint or mark the helmet with any kind of ink marker.
- Bump caps have no AS compliance but may comply with international bump cap standards.
- A safety helmet placed on the parcel shelf of a car becomes a missile in a collision.
- Do not use any solvent for helmet cleaning - warm soapy water only.
- Match same brand accessories to safety helmets wherever possible.

All workers should be trained in the correct use and maintenance of personal protective equipment.

USEFUL REFERENCES

AS/NZS 1801:1997 Occupational Protective Helmets.

AS/NZS 1800:1998 Occupational Protective Helmets - Selection, care and use.

HARD HATS & VISORS	6
BUMP CAPS	8
SOFT HEADWEAR	9
ACCESSORIES	10

3M

Vented Hard Hat

- Type 1 general purpose ABS safety helmet
- 6-point terylene head harness for greater stability and comfort
- Top venting for cool, comfortable protection
- Accessory slots for attachment of hearing and face protection
- Also available in polycarbonate high heat (Type 2)
- Optional ratchet headband available
- Certified to AS/NZS 1801:1997



CODE	DESCRIPTION	COLOURS	UOM
HC570	Vented ABS	Blue, Green, White, Yellow, Red, Fluoro Orange, Fluoro Yellow, Grey, Orange, Watermelon	Ea
HC570R	Vented ABS Ratchet	Blue, White, Yellow, Red, Fluoro Yellow, Orange	Ea
HC590	Vented Polycarbonate	White, Yellow, Fluoro Yellow, Fluoro Lime	Ea

3M

Reflective Tapes

- For improved visibility for low light/night applications
- Choice of tape format and type (25mm)
- Approved as a safety hard hat accessory
- Some tape options are factory fitted only



CODE	DESCRIPTION	UOM
HCXTA180	Tape Kit - 2 Curved, 1 Straight - Self or Factory Fitted	Ea
HCXTAPE1	2 Side Strips - Silver - Factory Fitted	Ea
HCXTAPE2	3 Strips on Front/Rear - Silver - Factory Fitted	Ea
HCXTAPE4	3 Strips on 4 Sides - White/Yellow/Red - Factory Fitted	Ea

3M

Accessories & Spares

- Accessories and spare parts for 3M™ HC560 and HC570 safety hard hats



CODE	DESCRIPTION	UOM
HCX095	Lambswool Sweat Band	Ea
HCX094	Terry Towel Sweat Band	Ea
HCX175	Elastic Chin Strap	Ea

3M

Logo Printing

- Up to 12 colours for standard size logos
- Up to 6 colours for extra large logos
- Minimum order: 20 units
- One-off setup charge on initial order
- Suitable artwork to be supplied



3M

Safety Logo Hard Hats

- 6-point terylene harness
- Unvented style
- Terry towel sweatband
- 25mm accessory slots
- Certified to AS/NZS 1801:1997



CODE	DESCRIPTION	UOM
HC560F04:GR	Logo Hard Hat "First Aid"	Ea
HC560C92:WH	Logo Hard Hat "Chief Warden"	Ea
HC560R27:RD	Logo Hard Hat "Fire Warden"	Ea
HC560W30:YL	Logo Hard Hat "Area Warden"	Ea
HC560V01:WH	Logo Hard Hat "Visitor"	Ea

3M

Hard Hat Attachable Visor Holder & Visors

Visor Holder

- Compatible with 3M™ HC560 and HC570 safety hard hats
- Accepts all visors - refer to page 17 for full range
- Made from heat resistant nylon, suitable for high temperature work areas
- Peaked version available



Visors

- Wide range of visors available to suit most applications
- High impact, heat resistant and chemical resistant visors available - Refer to page 17 for full range.



CODE	DESCRIPTION	RATING	UOM
HCX500	Visor Holder	Molten Metal/Hot Solids (M) & Chemical Splash Proof (C)	Ea
VVC730	1.0mm P/C - 200 x 385mm	High Impact Resistant	Ea
VVC848	1.0mm P/C - 200 x 300mm	High Impact Resistant	Ea
VVM820	Aluminium Mesh - 150 x 385mm	Low Impact Resistant	Ea



Logo Printing

- Pad print up to five colours on front, back and sides
- Customise hard hats with your logo, or to identify roles or specific project names
- Vinyl cut print options available - no size or position restrictions
- Pad & vinyl printing services will not interfere with the chemical or structural integrity of the materials used in the hard hat



Hard Hat Wide Brim Attachments

- Fits HCV6 style helmets
- Reduces sun exposure to face and neck
- Durable cotton drill fabric or plastic brim models
- Cap not included



CODE	DESCR.	COLOURS	UOM
HCXB173	Cotton Brim	White, Blue, Green, Orange, Yellow	Ea
HCXV6PB	Plastic Brim	White, Blue, Green, Fluoro Orange, Fluoro Yellow	Ea



Hard Hat Attachable Earmuffs

Refer to page 22 for details.

Viper® Universal

- Low clamping force
- Solid, lightweight earcup construction

Python® Slimline HI VIS

- Steel wire headband
- Lightweight earcup with high quality ear cushions



CODE	DESCRIPTION	UOM
ECVIP	Viper® Cap Attachable CL5 - SLC80 26dB(A)	Ea
ECPYTS	Python® Slimline HI VIS Cap Attachable CL5 - 31dB(A)	Ea



Accessories/spares to suit ProChoice HCV6 and HCV6P hard hats.

Cotton Sweat Band

- Replaceable for hygiene & comfort

Elastic Chin Strap

- Adjustable strap

Replacement Harness

- 6-point PushLock harness



CODE	DESCRIPTION	UOM
HCX061	Elastic Chin Strap	Ea
HCX062	Cotton Terry Sweat Band	Ea
HCX060	Replacement PushLock Harness	Ea



V6 Vented Safety Hard Hat

- Lightweight vented ABS plastic shell



- Air vents prevent perspiration build-up
- Extended peak for added protection
- Earmuffs and visors are easily attached via moulded accessory slots
- 6-point PushLock for secure fit
- Cotton sweat band



ProChoice safety caps are certified to AS/NZS 1801

CODE	DESCRIPTION	COLOURS	UOM
HCV6	Vented Cap PushLock	Orange, Green, Fluoro Yellow, Blue, White, Red, Black, Yellow	Ea



Hard Hat Attached Visor Holder & Visors

Visor Holder

- Compatible with ProChoice HCV6 and HCV9 hard hats
- Suits all ProChoice visors
- Fitted with QuickLock clips for easy visor replacement
- Can be used with ProChoice Viper® and Python® earmuffs



Visors

- Anti-fog 2mm polycarbonate (VVC900E excluded)
- 99.9% UV protection
- Certified to AS/NZS 1337.1:2010 for Extra High Impact, Molten Metals and Hot Solids (mesh visor excluded)



CODE	DESCRIPTION	UOM
HCX800	Visor Holder for Visor and/or Muff	Ea
VVC900	Visor Clear P/C - 205mm x 450mm - Anti-fog	Ea
VVS900	Visor Smoke P/C - 205mm x 450mm - Anti-fog	Ea
VVW900	Visor Green Shade - 205mm x 450mm - Anti-fog	Ea
VVC900E	Visor Clear - 205mm x 450mm - Non Anti-fog	Ea
VVM900	Visor Mesh Stainless Steel - 390mm x 197mm	Ea
VVC900CG	Visor Clear P/C Chinguard - 410mm x 260mm - Anti-fog	Ea



V9 Vented Safety Hard Hat

- Low profile and lightweight design in impact resistant ABS material
- Built-in sweatband
- Easy locking harness system for fast on/off application
- Nine points of ventilation
- Webbed harness cradling system
- Also available unvented
- Certified to AS/NZS 1801



HCV9PB
(CAP SOLD SEPARATELY)

CODE	DESCRIPTION	COLOURS
HCV9	Vented Pushlock	Blue, Green, Orange, Fluoro Orange, Red, White, Yellow, Fluoro Yellow, Black, Fluoro Pink
HCV9R	Vented Ratchet	Blue, Green, Orange, Red, White, Yellow, Fluoro Yellow
HCV9PB	Replacement Pushlock Harness	Blue, White, Green, Fluoro Orange, Fluoro Yellow



V6 Full Brim Hard Hat

- Lightweight hat with 6-point ratchet harness
- Extended brim over the neck and ears
- Built-in cotton sweatband
- Available in vented and unvented styles
- Certified to AS/NZS 1801



CODE	DESCRIPTION	COLOURS
HHV6FB	V6 Vented Hat	White, Green, Red, Yellow, Orange
HH6FB	V6 Unvented Hat	Yellow, White



Airborne Micro Peak Industrial Hard Hat

- 10mm micro peak for improved peripheral vision
- Full ABS shell with 6-point HDPE/nylon ratchet harness and adjustable chin strap
- Universal attachment slot for visors & earmuffs
- Airborne Linesman model suitable for use in low voltage installations (EN 50365)
- AS/NZS 1801 certified



HCV6MP

CODE	DESCRIPTION	COLOURS
HC6MP	Airborne Linesman Unvented Micro Peak	White, Yellow, Orange
HCV6MP	Airborne Vented Micro Peak	White, Yellow, Orange



Baseball Style Bump Caps

- Stylish adjustable design in standard or short peak
- 65% cotton, 35% polyester
- EN 812 standards compliant



HCBCG:BG

HCBSP1:FY

CODE	DESCRIPTION	COLOURS	UOM
HCBCG:BG	Baseball Style Bump Cap	Black/Grey	Ea
HCBCO:FO	Baseball Style Bump Cap	Fluoro Orange	Ea
HCBSP1:FY	Baseball Style Bump Cap Short Peak	Fluoro Yellow	Ea
HCBSP2:NV	Baseball Style Bump Cap Short Peak	Navy	Ea

3M PELTOR™

G2000 Lumberjack Kit

- Combines head, face and hearing protection for forestry and gardening industries
- Helmet: G2000 ABS shell - AS/NZS 1801 (Type 1)
- Visor: V4C stainless steel mesh - AS/NZS 1337.2 (Low Impact)
- Earmuff: H31 cap attached - AS/NZS 1270 (SLC80 28dB(A) - Class 5)
- Includes rainshield neck protection



CODE	DESCRIPTION
HCVMK2000	G2000 Lumberjack Kit - Orange
VVM4G	Low Impact Steel Mesh Visor Matt Finish 130mm x 155mm
VVM4B	Low Impact Polyamide Mesh Visor Matt Finish 130mm x 155mm
VVCV2C	High Impact Polycarbonate Visor Clear AF/AS 308mm x 210mm
VVCV4K	High Impact Polycarbonate Visor Clear AF/AS 455mm x 247mm



Tuffmaster 1 Wide Brim Hard Hat

- Unvented style
- 50mm wide brim
- Adjustable headband
- Lightweight shell, ABS Type 1 or polycarbonate Type 2 for high temperatures
- 6-point terylene harness



CODE	DESCRIPTION	COLOURS
HH40	ABS Type 1 Hat	White, Green, Red, Yellow, Orange, Blue, Grey
HH44	Polycarbonate Type 2 Hat	White, Green, Red, Orange



Bushfire Helmet

- Approved Type 3 for bushfire/ wildfire applications
- Polycarbonate heat and chip resistant material
- Lightweight design
- 6-point nylon webbing headgear
- Includes sweat band, FR neck protector and reflective tape
- Certified to AS/NZS 1801:1997



HEBHF44V

CODE	DESCRIPTION	COLOURS
HEBHF44	Polycarbonate Type 3 c/w Chin Strap	White, Orange, Yellow
HEBHF44V	Polycarbonate Type 3 c/w Chin Strap/Visor	White



First Base 3 Bump Caps

- Lightweight and comfortable
- Mesh ventilation
- Moisture wicking fabric sweatband
- EN 812 standards compliant



HCB23CRP

HCB23ERP

CODE	DESCRIPTION	COLOURS	UOM
HCB23CRP	Classic Reduced Peak (55mm Peak)	Black, HI VIS Orange, HI VIS Yellow, Navy	Ea
HCB23CMP	Classic Micro Peak (25mm Peak)	Navy	Ea
HCB23ERP	Elite Reduced Peak (55mm Peak)	Navy/Grey	Ea



Nullarbor Hat Standard

- Cool cotton drill and open cell foam laminate
- Squashable, flexible brim
- Absorbent, soft terry towelling lining
- UPF 50+



CODE	COLOURS	SIZES
HS300	Navy, Khaki, Black, Green, Grey	S - 3XL



Nullarbor Hat Micro Mesh HI VIS

- Double sided cotton drill brim with micro mesh gusset
- Absorbent, soft terry towelling lining
- Squashable, flexible brim
- UPF 50+



CODE	COLOURS	SIZES
HS200	Navy or Green Brim with either Yellow or Orange Gusset	S - 3XL



Nullarbor Hat Breeze

- Mesh gusset provides excellent airflow
- Squashable, flexible brim
- Comfortable and cool
- Cotton drill and open cell foam laminate
- Top and brim UPF 50+



CODE	COLOURS	SIZES
HS400	Navy, Khaki, Black, Green, Grey	S - 3XL



Canning Hat Breeze

- Made from premium, water resistant canvas with a durable yet soft feel finish
- 9cm brim with brimlock edging
- Built in absorbent brow lining
- Breathable open mesh gusset
- Top and brim UPF 50+



CODE	COLOURS	SIZES
HS925	Black, Khaki, Sand	S - 3XL



Earmuff Hat

- Sun protection while you're wearing earmuffs
- Wear with or without regular earmuffs (earmuffs not included)
- Extremely durable
- Cotton drill
- Flexible brim
- UPF 50+



CODE	COLOURS	SIZES
HS800	Navy, Khaki, Green, Grey	S - XL



Canning Hat Standard

- Made from premium, water resistant canvas with a durable yet soft feel finish
- 9cm brim with brimlock edging
- Built in absorbent brow lining
- UPF 50+



CODE	COLOURS	SIZES
HS900	Black, Blue, Khaki, Orange, Pink, Sand, Yellow	S - 3XL



Straw Hat

- Wide brim sun protection
- HI VIS orange band
- Durable
- Lightweight
- Adjustable toggle strap
- Available in four sizes: S=55cm, M=57cm, L=59cm, XL=61cm



CODE	COLOURS	SIZES
HSH	Orange HI VIS Band	S, M, L, XL



Sun Hat

- Wide protective brim
- Polyester/cotton fabric
- Adjustable chin strap
- Available in four sizes: S=55cm, M=57cm, L=59cm, XL=61cm
- UPF 50+



CODE	COLOURS	SIZES
HSCSH	White, Navy Blue, Green	S, M, L, XL



Tammin Hat

- Lightweight, cool and comfortable broad brim hat with long neck flap
- Microfibre fabric
- UPF 50+ head and neck protection



CODE	COLOURS	SIZES
HSTM	Blue, Green, Stone, White, Navy, HI VIS Orange, HI VIS Yellow	S - 2XL



Gobi Over Hat

- Micro mesh
- Fits over most hard hats
- Releasable back panel
- UPF 50+ head and neck protection
- Also available in 100% cotton
- Also available in Fire Retardant



CODE	COLOURS	SIZES
HSGBM	Navy, Pink, HI VIS Orange, HI VIS Yellow	One Size



Hard Hat Flap

- Quick and easy elasticised method to attach to the brim of hard hats
- Lightweight, cool and comfortable micro mesh
- UPF 50+ head and neck protection
- Also available in Fire Retardant



CODE	COLOURS	SIZES
HSHHFM	Navy, HI VIS Orange, HI VIS Yellow	One Size



Attach-A-Flap

- Lightweight, micro mesh adjustable head covering that attaches to your hard hat or cap
- Can be worn with earmuffs
- UPF 50+ head and neck protection
- Also available in Fire Retardant



CODE	COLOURS	SIZES
HSAAF	Grey, White, Navy, Aqua, Bone, HI VIS Orange, HI VIS Yellow	One Size



Easy View Net

- Extra long net for use over hard hats, peak caps, broad brim hats etc.
- Provides protection from flies and mosquitoes
- Hat not included



CODE	COLOURS	SIZES
HSEVN	Black	One Size



Brim 'N Shade

- Adds exceptional sun protection to most hard hats
- Durable polycotton
- Generous neck flap
- Wide brim for extra protection
- Easy to attach for a secure fit
- Packs flat for easy storage
- UPF 50+



CODE	COLOURS	SIZES
HSBNS	Standard - Navy, Orange, White, Silver Grey	One Size
HSBNSR	Fire Retardant - Orange	One Size



Hard Hat Emblems

- Vinyl self sticking material

51mm diameter (pack of 4)



SSD42241



SSD42232



SSD45332



SSD42284



SSD49573



SSD42245

56mm diameter (each)



SSD845736



SSD845734



SSD845735



SSD845738



SSD845739



SSD838414

EYE & FACE PROTECTION

APPLICATION

When engineering and administrative controls are unable to remove the potential for eye and/or face injuries, suitable PPE must be worn. This assessment must also apply to passers-by and nearby workers.

RISK ASSESSMENT

When determining a need for eye protection, carry out a risk assessment of the task to ensure that the correct specification for eye protection is chosen. Never assume that the present choice is the right one.

Consider:

- Prescription eyewear for workers with vision weaknesses. Be aware of the risk of reader inserts in standard protective eyewear ie. the capacity to distort walking vision eg. on stairs.
- Low, Medium, High and Extra High (switching work) energy impact risks.
- Chemical, microbiological, hot materials and cryogenic liquids (chin guard attachments are essential for splash risk). LPG re-gassing is a cryogenic liquid eye injury risk.
- Welding operations require careful risk assessment including protection for welder's assistants.
- Laser protection for Classes 3, 3A and 4 must comply with the laser manufacturer's recommendations.
- Provision of emergency eyewash and first aid. Refer to the Health & Hygiene and Site Safety sections of this catalogue.
- Eye Protection Signs conforming to AS 1319:1994 - Safety signs for the occupational environment.

AS/NZS 1337.1:2010 lists four impact ratings. These are Low, Medium, High and Extra High. Impact protection situations are listed in that standard. Extra High Impact rating visors must be used for electrical maintenance - refer page 57.

MARKING OF EYE PROTECTORS

In line with the proposed ISO standard, the following lens markings for Eye Protectors may apply:

TYPE OF LENS	LENS MARKING
Outdoor Use Untinted	"O"
Low Impact	"S" - optional
Medium Impact	"I" or "F"
High Impact	"V" or "B"
Extra High Impact	"A"
Splash Proof	"C" or "3"
Molten Metal	"M" or "9"
High Temperature	"H"

SAFETY PRESCRIPTION EYE PROTECTION

Amendments to AS/NZS 1337.6 Prescription Eye Protectors against Low and Medium Impact, state that prescription eye protection must be compliant with a standards testing protocol in order to be worn in the workplace. This standard now requires manufacturers of workplace prescription safety eyewear to be licensed.



SAFETY TIPS

- Spectacle arms can compromise hearing protection when ear muffs are worn.
- Eye protection may be compromised by respiratory protection. Check the two together.
- Grinding and cutting protection must include both a high impact face shield AND medium impact safety spectacles.
- Do not allow workers on site with non-compliant eyewear eg. fashion sunglasses.
- Ensure that a welding cover/chipping lens has a suitable impact rating.

All workers should be trained in the correct use and maintenance of personal protective equipment.

USEFUL REFERENCES

AS/NZS 1336:2014 Eye and face protection guidelines.

AS/NZS 1337.6:2012 Personal eye protection - Prescription eye protectors against low and medium impact.

AS/NZS 1337.1:2010/Amdt 1:2012 Eye and face protection for occupational applications.

AS/NZS 1338.1:2012 Filters for eye protectors.

SPECTACLES	12
GOGGLES	16
FACE SHIELDS	17
WELDING PROTECTION/ACCESSORIES	18

bolle

SAFETY



VSS1662302

Rush+

- Ultra lightweight
- Co-moulded temple tips for superior comfort and grip
- Platinum® anti-scratch/anti-fog lens coating (both sides) as indicated
- Adjustable PVC nose bridge

Rush+ Seal

- Features an SBR "positive seal" gasket and strap kit to maximise protection in dusty environments



VSC1662301FB

Rush+ Small

- Adopts all the features of the Rush+, just in a smaller fit



VSC1672301

CODE	DESCRIPTION	FRAME	LENS
VSC1662301	Rush+	Red/Black	Clear AS/AF
VSS1662302			Smoke AS/AF
VSM1662310			Twilight AS/AF
VSM1662318			Contrast AF
VSM1662306			ESP AF
VSC1662301FB	Rush+ Seal	Red/Black	Clear AS/AF
VSS1662302FB			Smoke AS/AF
VSS1662310FB			Twilight AS/AF
VSC1672301	Rush+ Small	Blue/Black	Clear AS/AF
VSS1672302			Smoke AS/AF

bolle

SAFETY

Rush

- Ultra lightweight
- Adjustable PVC nose bridge
- Co-moulded temple tips for superior comfort and grip
- Anti-scratch/anti-fog lens coating



CODE	LENS	CODE	LENS
VSC1652301	Clear AS/AF	VSM1652310	Twilight AS/AF
VSS1652302	Smoke AS/AF	VSARUSHPSJ	Amber AS/AF

bolle

SAFETY

Silex/Silex+

- Extended browguard
- Co-injected PC/TPR temples
- Soft and pliable 160° FLEX temples
- Ultra sleek sporty styling with panoramic vision
- Platinum® anti-scratch/anti-fog lens coating (both sides) as indicated



CODE	LENS SILEX	CODE	LENS SILEX+
VSCSILEXPSI	Clear AS/AF	VSCSILEXPPSI	Clear AS/AF
VSSSILEXPSF	Smoke AS/AF	VSSSILEXPPSF	Smoke AS/AF
VSASILEXPSJ	Yellow AS/AF	VSCSILEXCSP	CSP AS/AF

bolle

SAFETY

Ness/Ness+

- Ultra wrap-around frame
- Panoramic field of vision
- Non-slip nose bridge
- Linear temple design - Ness+ includes co-injected PC/TPR temples
- Anti-scratch/anti-fog lens coating - Ness+ Platinum® coating (both sides) as indicated



CODE	LENS	CODE	LENS
VSCNESSPSI	Clear AS/AF	VSCNESSPPSI	Clear AS/AF
VSSNESSPSF	Smoke AS/AF	VSSNESSPPSF	Smoke AS/AF
		VSCNESSPCSP	CSP AS/AF

bolle

SAFETY

Prism

- Ultra lightweight frame
- All polycarbonate frame with no metal parts
- Anti-scratch/anti-fog lens coating as indicated



CODE	LENS	CODE	LENS
VSC1614401	Clear AS/AF	VSM1614403	Silver Flash HC
VSS1614402	Smoke AS/AF	VSB1614404	Bronze AS/AF

bolle

SAFETY

Blade

- Lightweight, all polycarbonate frame
- High contour 10 base curve lens
- Anti-scratch/anti-fog lens coating



CODE	LENS	CODE	LENS
VSC1668201	Clear AS/AF	VSS1668202	Smoke AS/AF

bolle

SAFETY

Ultim8

- PC/TPR pivoting temples
- TPR waterproof foam
- Adjustable and removable strap
- Platinum® anti-scratch/anti-fog lens coating (both sides)



CODE	LENS
VSCULTIPSI	Clear AS/AF

bolle

SAFETY

Baxter

- Wrap-around frame
- Removable waterproof foam strap
- Protection against sprays of solids, liquids and dusts (no chemical rating)
- Platinum® anti-scratch/anti-fog coating (both sides) as indicated



CODE	LENS	CODE	LENS
VSC1678101	Clear AS/AF	VSC1678118	CSP AS/AF
VSS1678102	Smoke AS/AF	VSP1678107	Smoke Polarised HC

BOLLÉ SAFETY eyewear is certified to AS/NZS 1337.1:2010 for Medium Impact Protection HC=Hard Coat, AS=Anti-Scratch, AF=Anti-Fog

bolle SAFETY

Tryon

- Ultra wrap-around frame with sports styling
- Adjustable non-slip bridge
- PC/TPR co-injected temples
- Temples 160° FLEX
- **P** Platinum® anti-scratch/anti-fog lens coating (both sides) as indicated



CODE	LENS	CODE	LENS
VSCTRYOPSI	Clear P AS/AF	VSCTRYOCSP	CSP P AS/AF
VSSTRYOPSF	Smoke P AS/AF	VSMTRYOFLASH	Blue Flash HC

bolle SAFETY

Tryon OTG

- Premium over-the-glasses frame
- Temples 160° FLEX
- PC/TPR adjustable co-injected temples
- Flexible upper forehead protection (TPR)
- **P** Platinum® anti-scratch/anti-fog lens coating (both sides)



CODE	LENS	CODE	LENS
VSCTRYOTGPSI	OTG Clear P AS/AF	VSSTRYOTGPSF	OTG Smoke P AS/AF

bolle SAFETY

Hurricane

- Dual lens spectacle with lightweight hydrated nylon frame
- Black velvet finish
- Anti-scratch/anti-fog lens coating as indicated



CODE	LENS	CODE	LENS
VSC1662201	Clear AS/AF	VSM1662204	Blue Flash HC
VSS1662202	Smoke AS/AF	VSP1662215	Green Polarised HC

bolle SAFETY

Prowler

- Black, high gloss, dual material frame delivers superior strength & flexibility
- Co-moulded temple arms with TP rubber
- Anti-scratch/anti-fog lens coating as indicated



CODE	LENS	CODE	LENS
VSC1626401	Clear AS/AF	VSM1626403	Silver Flash HC
VSS1626402	Smoke AS/AF	VSM1626404	Blue Flash HC

bolle SAFETY

Phantom

- Gloss, jet black nylon frame
- Rubber nose pads and temple tips for a non-slip, comfortable fit
- Anti-scratch/anti-fog lens coating as indicated



CODE	LENS	CODE	LENS
VSS1651102	Smoke AS/AF	VSP1651107	Grey Polarised HC

bolle SAFETY

Contour / Contour Metal

- High gloss, dark gunmetal frame
- Comfort nose pads & temple tips
- **P** Platinum® anti-scratch/anti-fog lens coating (both sides) as indicated



CODE	LENS	CODE	LENS
VSC1615501	Clear P AS/AF	VSP1652107	Grey Polarised HC
VSS1615502	Smoke P AS/AF	VSCCONTMPSI	Clear Metal AS/AF
VS1615505	Bronze P AS/AF	VSSCONTMPSF	Smoke Metal AS/AF
VSA1615503	Amber P AS/AF	VSMCONTMESP	ESP Metal AS
VSM1615504	ESP Dark AF		

bolle SAFETY

Silium+

- Ultra lightweight frame
- Straight, highly flexible ergonomic temples
- Non-slip adjustable nose bridge
- **P** Platinum® anti-scratch/anti-fog lens coating (both sides)



CODE	LENS	CODE	LENS
VSC1676101	Clear P AS/AF	VSC1676118	CSP P AS/AF
VSS1676102	Smoke P AS/AF		

bolle SAFETY

Hustler

- Black, high gloss frame
- Rubber nose pads and EVA temple tip inserts
- Provides true colour definition while fighting harsh glare - 99.9% UV protection
- Anti-scratch/anti-fog lens coating as indicated



CODE	LENS	CODE	LENS
VSS1652602	Smoke AS/AF	VSP1652618	Blue Mirror Polarised AS/AF
VSP1652607	Grey/Green Polarised HC		

bolle SAFETY

Voodoo

- Translucent polycarbonate frame
- Rubber nose pads and EVA temple tip inserts
- Distortion free lens
- Anti-scratch/anti-fog lens coating as indicated



CODE	LENS	CODE	LENS
VSS1652702	Smoke AS/AF	VSP1652707	Grey/Green Polarised HC
VS1652705	Brown AS/AF	VSP1652719	Brown Polarised HC



Cirrus

- Super flexible with ergonomic lens design
- Co-injected arms for soft temple tips and ultimate comfort
- Anti-fog and anti-scratch lens
- 99.9% UV protection for outdoor wear

CODE	LENS	CODE	LENS
VSC9180	Clear HC/AF	VSS9182	Smoke HC/AF
VSC9188	Indoor/Outdoor HC/AF	VSA9185	Amber HC/AF



Harpoon 261

- Polycarbonate one-piece lens
- Nylon side arms
- Comfortable, soft and flexible temple ends
- Anti-scratch/anti-fog lens coating as indicated

CODE	LENS	CODE	LENS
VSC261	Clear HC	VSC261AF	Clear HC/AF
VSS261	Smoke HC	VSS261AF	Smoke HC/AF
VSM261:BL	Blue Mirror HC	VSM261:SL	Silver Mirror HC



The General

- 99.9% UV protection
- Polycarbonate lightweight frame
- Anti-scratch/anti-fog lens coating
- Optional soft TPR gasket for exceptional protection against dust, mist and particles

CODE	LENS	CODE	LENS
VSC6400	Clear HC/AF	VSA6405	Amber HC/AF
VSS6402	Smoke HC/AF	VSB6409	Brown HC/AF



Vortex

- Lightweight one-piece polycarbonate lens
- Wrap-around styling
- Frosted arms and nose bridge
- Anti-fog/anti-scratch lens coating as indicated

CODE	LENS	CODE	LENS
VSC212	Clear HC	VSC212AF	Clear HC/AF
VSS212	Smoke HC	VSS212AF	Smoke HC/AF



Richter

- Ultra lightweight, wrap-around style spectacle
- Nine base curve
- Flexible temple tips
- Anti-scratch/anti-fog lens coating

CODE	LENS	CODE	LENS
VSC6300	Clear HC/AF	VSM6309	Brown Silver Flash HC/AF
VSS6302	Smoke HC/AF		



Citron 296

- One-piece lens
- Sleek wrap-around design
- Flexible rubber nose pads
- Lightweight and comfortable
- Anti-scratch/anti-fog lens coating as indicated

CODE	LENS	CODE	LENS
VSC296	Clear HC	VSC296AF	Clear HC/AF
VSS296	Smoke HC	VSS296AF	Smoke HC/AF



Mercury

- Lightweight, durable polycarbonate frame
- Adjustable nose bridge
- Anti-scratch/anti-fog lens coating

CODE	LENS	CODE	LENS
VSC8200	Clear HC/AF	VSS8202BK	Smoke HC/AF
VSS8202	Smoke HC/AF	VSP8212	Smoke Polarised HC/AF



Maverick 242

- Two-piece lens
- Feathered nose pads
- Soft, rubberised temple ends
- Anti-scratch, hard coat lens coating

CODE	LENS	CODE	LENS
VSS242	Smoke HC	VSP242	Smoke Polarised HC



Visitors Economy Safety Glasses

- One-piece lens provides unobstructed 180° view
- Deep frame design for use with prescription glasses

CODE	LENS	CODE	LENS
VSC160	Clear	VSS161	Smoke



Reader 101

- Two-piece bifocal lens
- Rubber insert temple ends
- Also available in smoke, silver mirror and plano options

*Note: Reader 101 is not certified to AS/NZS 1337.1:2010

CODE	LENS	CODE	LENS
VSC101R:1.5	1.5 Mag Clear H/C	VSC101R:2.5	2.5 Mag Clear H/C
VSC101R:2.0	2.0 Mag Clear H/C	VSC101R:3.0	3.0 Mag Clear H/C

PROCHOICE safety eyewear is certified to AS/NZS 1337.1:2010 for Medium Impact Protection

HC = Hard Coat (Anti-Scratch)
AF = Anti-Fog

VISIONSAFE safety eyewear is certified to AS/NZS 1337.1:2010 for Medium Impact Protection*



Helios

- Stylish, lightweight, wrap-around design
- Contoured nine base lens
- Flexible, vented, TPR padded pillow flex side arms
- Clip-on/off dust guard for improved seal available
- Adjustable spectacle strap available
- Anti-static lenses with anti-scratch/anti-fog coating



DUST GUARD
VXS915DG



CODE	FRAME	LENS	CODE	FRAME	LENS
VSC9151	Black/Red	Clear H/P HC/AF	VSB9155	Black/Grey	Brown HC/AF
VSS9152	Red	Smoke H/P HC/AF			



Buster

- Floating lens
- 100% UV protection
- Wrap-around sports style
- Co-moulded temple arms
- Anti-scratch/anti-fog lens coating as indicated



CODE	LENS	CODE	LENS
VSC101	Clear HC/AF	VSA101	Amber HC/AF
VSS101	Smoke HC	VSM101	Blue Mirror HC



Wasp

- Wrap-around design
- Soft nose pads
- Lightweight, anti-static nine base lens
- Flexible, co-moulded, padded side arms
- Anti-scratch/anti-fog lens coating



CODE	LENS	CODE	LENS
VSC0131	Clear HC/AF	VSS0132	Smoke HC/AF



Bark Hut

- Smooth rubberised frame
- Soft fit facial feel
- Options include clip-on/off dust guard
- Anti-scratch/anti-fog lens coating



POLARISED
OPTION

CODE	LENS	CODE	LENS
VSS007	Smoke HC/AF	VSP007	Smoke Polarised HC/AF
VSS007DG	Smoke HC/AF Dustguard		



Ecko

- Ultra lightweight design
- 100% UV protection
- Wrap-around polycarbonate frame
- Anti-scratch/anti-fog lens coating as indicated



CODE	LENS	CODE	LENS
VSC170	Clear HC/AF	VSM170	Clear Mirror HC
VSS170	Smoke HC		



Hypershock

- Lightweight, wrap-around frame provides increased side protection
- Streamlined padded temples and a moulded nose piece for a secure, comfortable fit
- Anti-scratch/anti-fog lens coating as indicated



POLARISED
OPTION



CODE	LENS	CODE	LENS
VSC1024851	Clear AF	VSB1024854	Expresso HC
VSC1024852	Clear HC	VSP1024856	Expresso Polarised HC
VSB1024853	Expresso AF	VSP1024858	Black Polarised HC



A700

- Sports style wrap-around design
- Nine base polycarbonate lens
- Soft temple tip pads for a secure fit
- Anti-scratch/anti-fog lens coating as indicated



CODE	LENS	CODE	LENS
VSC1015360	Clear AF	VSA1015441	Amber HC
VSS1015351	Grey AF	VSM1015442	Light Brown Mirror AF



Pinnacle

- Soft temple tips provide a comfortable fit for all day wear
- 100% dielectric with no metal parts
- Anti-fog/anti-scratch lens coating



CODE	LENS	CODE	LENS
VSC1037540	Clear HC/AF	VSA1037544	Amber HC/AF
VSS1037542	Grey HC/AF	VXS1037541	Positive Seal Foam Gasket



Chill

- Lightweight design
- Flexible temples
- Comfort moulded nose piece
- Wrap-around nine base
- Anti-scratch/anti-fog lens coating as indicated



CODE	LENS	CODE	LENS
VSC200XV	Clear HC	VSC205XV	Clear AF
VSS201XV	Grey HC	VSS206XV	Grey AF



XC®

- Lightweight 36gm
- Wrap-around styling
- Extendable arm lengths and temple pivot points
- Optional RX insert for prescription use
- Anti-scratch/anti-fog lens coating as indicated



CODE	LENS	CODE	LENS
VSC1011027	Clear AF	VSM1011023	Light Silver Mirror AS
VSS1011025	Smoke Grey AF	VSM1011022	Silver Mirror AS

3M safety eyewear is certified to AS/NZS 1337.1:2010 for Medium Impact Protection

HC = Hard Coat (Anti-Scratch)
AF = Anti-Fog

HONEYWELL safety eyewear is certified to AS/NZS 1337.1:2010 for Medium Impact Protection

bolle SAFETY

Blast Goggle

- Low profile PVC frame
- Vent options
- Polycarbonate lens with anti-scratch/anti-fog lens coating
- Can be worn over spectacles and disposable respirators
- Close-cell foam seal for dust protection



VGX1669203

CODE	DESCRIPTION	UOM
VGC1669101	Clear/Top Vent Closed AS/AF	Ea
VGC1669201	Clear/Indirect Vents AS/AF	Ea
VGC1669203	Clear/Indirect Vents c/w Mouth Guard AS/AF	Ea
VGX1669204	Mouth Guard	Ea

bolle SAFETY

Pilot 2 Goggle

- Ventilated frame
- Fits over prescription glasses
- *P Platinum® anti-scratch/anti-fog lens coating



CODE	DESCRIPTION	UOM
VGC1679110	Clear *P AS/AF	Ea
VGS1679112	Smoke *P AS/AF	Ea

bolle SAFETY

Atom Goggle

- Comfortable, compact and lightweight TPR frame
- Fits over prescription spectacles
- *P Platinum® anti-scratch/anti-fog lens coating



CODE	LENS/FRAME	UOM
VGC1652801	Clear *P AS/AF Indirect Vents Top/Bottom	Ea
VGC1652821	Clear *P AS/AF Top Vents Closed	Ea
VGS1652802	Smoke *P AS/AF Indirect Vents Top/Bottom	Ea
VGS1652822	Smoke *P AS/AF Top Vents Closed	Ea

VISION Safe

Flex 440 Goggle

- Fully flexible twin lens frame with side vents & soft foam seal
- Wide fit adjustable headband
- Anti-scratch/anti-fog lens coating



CODE	DESCRIPTION	UOM
VGC440	Clear HC/AF	Ea
VGS440	Smoke HC/AF	Ea

PRO PRO CHOICE SAFETY GEAR

Vadar Goggle/Mask Combo

- Wide peripheral vision and face coverage
- Anti-fog lens
- Multiple vents for increased airflow and minimal lens fogging
- Goggle and face shield can detach
- 99.9% UV protection for outdoor



CODE	DESCRIPTION	UOM
VGC5000	Clear AF	Ea
VGS5002	Smoke AF	Ea

PRO PRO CHOICE SAFETY GEAR

Cyclone Goggle

- Spherical anti-fog, liquid splash protection lens
- 99.9% UV protection
- Foam bound, wide head strap & indirect vents enhances user comfort



VG6000

VG66FRO

CODE	DESCRIPTION	UOM
VGC6000	Cyclone Clear AF	Ea
VGS6002	Cyclone Smoke AF	Ea
VG66FRO	Inferno Fire Retardant AF/AS Foam Bound Indirect Vents	Ea

3M

GoggleGear™ 500 Series Goggle

- Low profile design
- Indirect ventilation
- Medium impact polycarbonate lens with 3M™ Scotchgard™ Anti-fog Technology
- Adjustable neoprene head strap
- Prescription lens insert available



CODE	DESCRIPTION	UOM
VGC501	Clear AF	Ea
VGZ500P1	Prescription Lens Insert	Ea

Honeywell

Maxx Pro™ Goggle

- Compact low profile design
- Splash and impact protection rated
- Anti-fog/anti-scratch lens
- Indirect venting system
- Fabric head strap



CODE	DESCRIPTION	UOM
VGC1011072	Clear HC/AF	Ea
VGS1011072	Smoke HC/AF	Ea

All safety eyewear on this page is certified to AS/NZS 1337.1:2010 for Medium Impact Protection

HC = Hard Coat
AS = Anti-Scratch
AF = Anti-Fog

All safety eyewear on this page is certified to AS/NZS 1337.1:2010 for Medium Impact Protection



Face Shield System

- High impact browguard
- Friction pivoting system for lifting and lowering
- Ratchet adjustable headband
- 1mm polycarbonate high impact visor
- Range of alternative visors to suit most applications
- AS/NZS 1337.1:2010 High Impact



VF105



CODE	DESCRIPTION	UOM
VF105	Face Shield c/w Clear P/C Visor 200mm x 300mm	Ea
VB997	Browguard	Ea
VWC848	Clear 1mm Visor Bound 200mm x 300mm	Ea



Polycarbonate High Impact Visors

- 1mm bound or unbound
- Safe operating temperature 105° C
- Resistance to water based liquids
- AS/NZS 1337.1:2010 High Impact & Splash



VVC730

CODE	DESCRIPTION	UOM
VWC848	Clear 1mm Visor Bound 200mm D x 300mm W	Ea
VVC730	Clear 1mm Visor Unbound 200mm D x 385mm W Flared	Ea
VVC501	Clear 1mm Visor Unbound 230mm D x 400mm W Chinguard	Ea



Thermotuff+ Heat/Chemical/High Impact Visors

- 1mm bound Thermotuff+
- Safe operating temperature 125° C
- Protection against harsh chemicals & splash
- AS/NZS 1337.1:2010 High Impact & Splash & Molten Metal



VVC875

CODE	DESCRIPTION	UOM
VVC875	1mm Visor Bound 200mm x 300mm	Ea
VVC876	1mm Visor Bound 200mm x 400mm Flared	Ea
VVC882	1mm Visor Unbound 250mm x 400mm Flared	Ea



Mesh Visors

- Metal mesh visors approved for protection against high levels of radiant heat
- Nylon (Forestry) mesh approved for protection against large dust particles and abrasion
- Low impact protection only: additional eye protection should be worn



VVMFCMY

CODE	DESCRIPTION	UOM
VVM602B	Brass Mesh 200mm x 300mm	Ea
VVM820	Aluminium Mesh 150mm x 385mm	Ea
VVMFCMY	Nylon Mesh 185mm x 360mm	Ea



Face Shield System

- Lightweight, ratchet adjustable browguard made from durable polyethylene
- Cotton sweat band
- QuickLock clips for quick and easy visor replacement
- Anti-fog polycarbonate visor
- Certified to AS/NZS 1337.1:2010 Extra High Impact, Molten Metal & Hot Solids Resistant



VF900



VB900 BROWGUARD ONLY

CODE	DESCRIPTION	UOM
VF900	Face Shield c/w Clear P/C Visor 405mm x 205mm	Ea
VB900	Browguard	Ea



Visor Range

- Anti-fog polycarbonate as indicated
- Clear/smoke with 99.9% UV protection
- Certified to AS/NZS 1337.1:2010 for Extra High Impact, Molten Metal & Hot Solids Resistant (Mesh Visor excluded)



VVC900CG



VVC900

VS900

VVW900

VVC900E

VVM900

CODE	DESCRIPTION	UOM
VVC900	Clear Visor P/C - 205mm x 450mm - Anti-fog	Ea
VS900	Visor Smoke P/C - 205mm x 450mm - Anti-fog	Ea
VVW900	Visor Green Shade - 205mm x 450mm - Anti-fog	Ea
VVC900E	Visor Clear - 205mm x 450mm - Non Anti-fog	Ea
VVM900	Visor Mesh Stainless Steel 390mm x 197mm	Ea
VVC900CG	Visor Clear P/C Chinguard - 410mm x 260mm - Anti-fog	Ea



Sphere Face Shield System

- Ultra wrap-around fit
- Adjustable headgear
- Tilting polycarbonate shield - 205mm x 394mm
- Splash protection
- High impact to AS/NZS 1337.1 2010



CODE	DESCRIPTION	UOM
VF1652501	Clear Face Shield	Ea
VVC1652513	Clear Visor	Ea
VFX1652525	Headgear Replacement	Ea



Welder's Face Shield

- High Impact gloss browguard
- Heat resistant Thermotuff+ shade 5 visor
- Browguard and visor sold separately
- AS/NZS 1337.1:2010 for Medium Impact Protection



CODE	DESCRIPTION	UOM
VB997	Browguard	Ea
VW901	Green Shade 5 Visor 200mm x 300mm	Ea



Tracker 2 Welder's Spectacle

- Rubberised eye seal
- Adjustable head strap
- Anti-scratch/anti-fog lens coatings
- Infrared absorbing dyes for total eye protection
- Available in two shades
- AS/NZS 1337.1.2010 for Medium Impact Protection



CODE	DESCRIPTION	LENS COLOUR	UOM
VSW1652016	Tracker 2 Spectacle	Shade 3 HC/AF	Ea
VSW1652017	Tracker 2 Spectacle	Shade 5 HC/AF	Ea

bolla SAFETY Cleaning Solutions & Accessories



VSXTB401
Cleaning Tissues Dry Pack



VSXSB600
Reusable Cleaning Station



VSXFB411
Lens Cleaner Spray



VSXWB100
Alcohol-free Lens Wipes



VSP3111408
Semi-hard Spectacle Case



VSXCUNIS
Universal Spectacle Strap

CODE	DESCRIPTION	UOM
VSXTB401	Multi-function Cleaning Tissues Dry Pack	Box/200
VSXSB600	Reusable Station c/w 500ml Spray, 2x200 Tissues	Ea
VSXFB411	Anti-reflective, Anti-static Lens Cleaner Spray 250ml	Ea
VSXWB100	Anti-reflective, Anti-static Wipes Dispenser	Box/100
VSP3111408	Semi-hard Spectacle Case	Ea
VSXCUNIS	Adjustable Spectacle Strap (Rush+/Tryon/Ultim8/ Ness/ Ness+)	Ea

Honeywell Cleaning Solutions



VSXS1011380
Disposable Cleaning Station



VSXS1011377
Reusable Cleaning Station



VSXW1011332
Alcohol-free Lens Wipes



VSXW16779
Anti-fog Wipes



VSXT1011379
Cleaning Tissues Dry Pack



VSXF1011378
Cleaning Solution Spray

CODE	DESCRIPTION	UOM
VSXS1011380	Disposable Station c/w Tissues & Spray Cleaner	Ea
VSXS1011377	Reusable Station c/w Tissues & Spray Cleaner	Ea
VSXW1011332	Lens Cleaning Wipes Alcohol-free Box	Box/100
VSXW16779	Reusable Dry Anti-fog Wipes Alcohol-free Box	Box/100
VSXT1011379	Lens Cleaning Tissues Dry Pack Box	Box/500
VSXF1011378	Lens Cleaning Fluid - Alcohol-free Spray 500ml	Ea

PRO SAFETY Cleaning Solutions & Accessories



VSPSP
Spectacle Pouch



VSXWAF100
Cleaning Wipes Anti-fog

CODE	DESCRIPTION	UOM
VSPSP	Microfabric Spectacle Pouch with Drawstring	Ea
VSXWAF100	Anti-fog Lens Clean Wipes Alcohol Free	Box/100

VISION Safe Accessories



VSXC500
Knitted Spectacle Cord



VSXC550
Cloth Tube Spectacle Strap

CODE	DESCRIPTION	UOM
VSXC500	Knitted Cord - Various colours available	Ea
VSXC550	Cloth Tube Strap - Various colours available	Ea



HEARING PROTECTION

APPLICATION

When higher ranking noise control measures are unable to reduce the exposure to noise **to or below the National Standard** (www.safeworkaustralia.gov.au), employees should be supplied with, and be trained on, the wearing and maintenance of effective personal hearing protectors.

RISK ASSESSMENT

The risk of over-exposure of workers to noise in a workplace must be assessed by conducting a **noise survey**. The purpose of a survey is to identify all work areas and work practices likely to expose workers to noise above the national 8 hour day standard (presently 85dB(A)) and must include work hour calculations if work hours exceed 8. The survey must also explain and record noise dose and identify peak noises.

A noise survey should audit the effectiveness of any existing measures and include recommendations that direct employers to measures that will reduce noise. Employers are required to provide appropriate PPE and train employees in the use and maintenance of personal hearing protectors.

When selecting hearing protectors the following must be considered:

- Weight and clamping force (for earmuffs) - refer to our quick reference guide at the end of this section.
- Suitability of protection for use and fit with other PPE such as helmets, spectacles, respirators etc.
- The inherent problems of comfort and supervising compliance.
- The interference of fit when wearing head clothing like hair nets, hoodies and beanies.

CLASSIFICATION TABLE

Hearing protectors are grouped into five classes that range from class 1 to class 5 based upon Australian Standards governed testing (Specified SLC 80, dB) as shown below:

SPECIFIED SLC80 FOR DETERMINATION OF CLASS		
Class	Specified SLC80, dB(A)	Effective Noise Range
1	10 - 13	90dB(A)
2	14 - 17	95dB(A)
3	18 - 21	100dB(A)
4	22 - 25	105dB(A)
5	26 or greater	110dB(A)

SLC80 (Sound Level Conversion) is a single number rating commonly used in Australia and New Zealand to compare the acoustic performance of hearing protectors. The subscript '80' indicates that in well-managed hearing protector programmes, the protection provided is expected to equal or exceed the SLC80 in 80% of protector-wearer noise spectrum combinations.



USEFUL REFERENCES

AS/NZS 1269.0:2005 Part 0 Occupational noise management - Overview and general requirements.

AS/NZS 1269.3:2005 Occupational noise management - hearing protector programme.

SAFETY TIPS

- Over-protection may cause wearers to remove hearing protection to communicate or miss warning sounds.
- Safety spectacle side arms and certain hair styles may affect the air seal of an earmuff.
- Replacement hygiene kits (ear cushions and foam inserts) will help maintain earmuff performance.
- Using earplugs in addition to earmuffs may add up to 3 decibels to the earmuff rating.
- Exposure to noise combined with certain chemicals absorbed into the blood stream will cause an ototoxic effect, accelerating noise induced hearing loss - wear protective gloves.
- Define extensive noise areas with appropriate signage

All workers should be trained in the correct use and maintenance of personal protective equipment.

EARPLUGS	20
EARMUFFS	22
ELECTRONIC/SPECIALTY MUFFS	25
PERFORMANCE GUIDE	26

3M E-A-R

E-A-Rsoft™ Neon Earplugs

- Smooth texture, tapered shape
- Single use
- Neon colour for compliance sighting
- Sizes available
- Extra soft foam for softer feel and lower ear canal pressure
- Corded and uncorded styles
- Earplugs correctly and consistently dispensed with the One-Touch™ Pro Dispenser - features 'No Waste Funnel' system



EP3111251 EPD3910000 EP3911004

CODE	DESCRIPTION	UOM
EP3121250	Neon Regular Uncorded CL4 - SLC80 23dB(A)	Box/200Pr
EP3111251	Neon Regular Corded CL4 - SLC80 23dB(A)	Box/200Pr
EPD3910000	One-Touch Pro Dispenser (Earplugs not included)	Ea
EP3911004	Dispenser Refill Neon Reg. CL4 - SLC80 23dB(A)	Box/500Pr

3M E-A-R

E-A-R™ Express™ Pod Earplugs

- Unique pod design for easy insertion
- Push-in fit, no roll-down required
- Reusable, washable, no sizing
- Soft, flexible grip for hygienic insertion
- Corded and uncorded styles

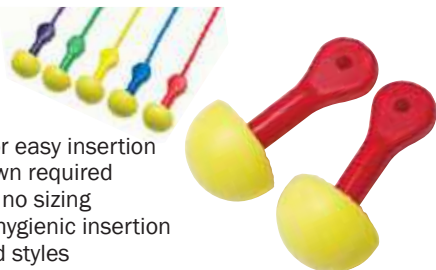

CODE	DESCRIPTION	UOM
EP3213200	Express Uncorded CL3 - SLC80 19dB(A)	Box/100Pr
EP3212115	Express Corded CL3 - SLC80 19dB(A)	Box/100Pr

3M E-A-R

E-A-R™ UltraFit™ Reusable Earplugs

- Pre-moulded soft plastic
- Reusable, washable, no sizing
- Corded and uncorded styles
- Triple flange tip for performance & comfort



CODE	DESCRIPTION	UOM
EP3404001	UltraFit Uncorded c/w Case CL3 - SLC80 18dB(A)	Box/50Pr
EP3404002	UltraFit Corded c/w Case CL3 - SLC80 18dB(A)	Box/50Pr
EP3404004	UltraFit Corded CL3 - SLC80 18dB(A)	Box/100Pr

3M E-A-R

Skull Screws™ Ear Plugs

- Push-to-fit design for easy and hygienic fitting
- Tough look of threaded metal, but feel of soft foam
- Corded and uncorded styles



CODE	DESCRIPTION	UOM
EP1300	Skull Screws Uncorded CL5 - 27dB	Box/120Pr
EP1301	Skull Screws Corded CL5 - 27dB	Box/120Pr

3M E-A-R

E-A-R™ Classic™ Earplugs

- Soft, energy absorbing foam
- Non-irritating
- Moisture resistant
- Flame resistant
- Corded and uncorded styles

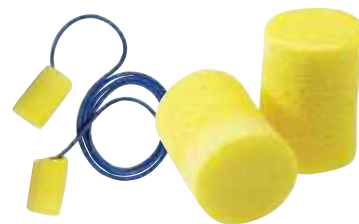

CODE	DESCRIPTION	UOM
EP3121201	Classic Uncorded CL4 - SLC80 23dB(A)	Box/200Pr
EP3111101	Classic Corded CL3 - SLC80 21dB(A)	Box/200Pr

3M E-A-R

E-A-Rsoft™ TaperFit™ II Earplugs

- Non-irritating polyurethane foam
- Single use, 'plus' size available
- Tapered shape for easy insertion and secure fit
- Corded and uncorded styles



CODE	DESCRIPTION	UOM
EP3121219	TaperFit II Regular Uncorded CL5 - SLC80 26dB(A)	Box/200Pr
EP3121221	TaperFit II Plus Uncorded CL5 - SLC80 26dB(A)	Box/200Pr
EP3121224	TaperFit II Plus Corded CL5 - SLC80 26dB(A)	Box/200Pr

3M E-A-R

E-A-Rsoft™ SuperFit™ Earplugs

- Soft foam with red line to indicate best fit
- Smooth texture tapered shape
- Single use, large size available
- Corded and uncorded styles



CODE	DESCRIPTION	UOM
EP3121256	Superfit Regular Uncorded CL4 - SLC80 24dB(A)	Box/200Pr
EP3121254	Superfit Regular Corded CL4 - SLC80 24dB(A)	Box/200Pr

3M E-A-R

E-A-Rsoft™ Metal Detectable Earplugs

- Soft foam for all day comfort
- Metal detectable
- Breakaway cord
- Single use, regular sizing

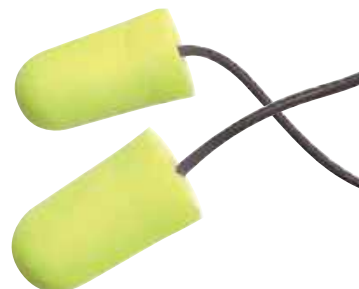

CODE	DESCRIPTION	UOM
EP3114106	Metal Detectable Corded CL4 - SLC80 23dB(A)	Box/200Pr

3M E-A-R

E-A-R™ Swerve™ Banded Earplugs

- Adjustable band for best fit and positioning
- Lightweight, durable plastic
- Includes 'Flex 28' and 'Comfort Pod' tip ends for wearer choice



CODE	DESCRIPTION	UOM
EP3222000	Swerve with Flex 28 CL3 - SLC80 20dB(A) and Comfort Pods CL4 - 23dB(A)	Pair

3M™ E-A-R™ earplugs are certified to AS/NZS 1270:2002

Honeywell Max® Polyurethane Earplugs



- Bell shaped polyurethane foam for maximum comfort
- Smooth, soil resistant skin prevents dirt build-up
- Contoured for easy insertion



CODE	DESCRIPTION	UOM
EPMAX1	Max Uncorded CL5 - SLC80 26dB(A)	Box/200Pr
EPMAX30	Max Corded CL5 - SLC80 26dB(A)	Box/100Pr
EPC400MAX1	Max Uncorded Refill Canister	Canister/400Pr

Honeywell Max Lite® Polyurethane Earplugs



- Contoured T-shape for easy handling and fit: ideal for people with smaller ear canals
- Low pressure PU foam
- Smooth, soil resistant skin



CODE	DESCRIPTION	UOM
EPLPF1	Max Lite Uncorded CL4 - SLC80 25dB(A)	Box/200Pr
EPLPF30	Max Lite Corded CL4 - SLC80 25dB(A)	Box/100Pr
EPC400LPF1	Max Lite Uncorded Refill Canister	Canister/400Pr

Honeywell Laser Trak® Detectable Earplugs



- Single use earplug
- Metalised polycord
- Non-ferrous metal grommet
- Visual and metal detectability
- Self-adjusting polyurethane foam
- Contoured T-shape for easy insertion

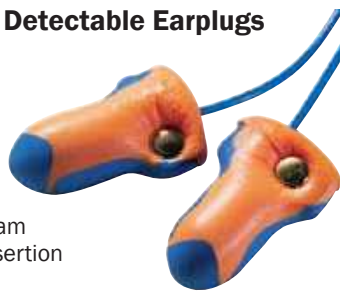

CODE	DESCRIPTION	UOM
EPLT30	Laser Trak Corded CL4 - SLC80 25dB(A)	Box/100Pr

Honeywell Earplug Dispenser & Kits



- Mount dispenser on the wall or place on tabletop for instant access
- Simply twist the knob to dispense one earplug at a time, saving expenses and eliminating package waste
- Canisters contain 400 pairs of earplugs

CODE	DESCRIPTION	UOM
EPD400	HL400 Earplug Dispenser Unit Plastic Base (Earplugs not included)	Ea
EPDK400LL1	Earplug Dispenser Kit - HL400 c/w Laser Lite Plugs	Ea
EPDK400LPPF1	Earplug Dispenser Kit - HL400 c/w MAX Lite Plugs	Ea
EPDK400MAX1	Earplug Dispenser Kit - HL400 c/w MAX Plugs	Ea
EPDK400XTR1	Earplug Dispenser Kit - HL400 c/w X-treme Plugs	Ea

Honeywell Laser Lite® Foam Earplugs



- Contoured T-shape for easy insertion and fit
- Vibrant colours for high visibility
- Smooth, soil resistant skin
- Self-adjusting polyurethane foam expands to fit



CODE	DESCRIPTION	UOM
EPLL1	Laser Lite Uncorded Plug CL4 - SLC80 25dB(A)	Box/200Pr
EPLL30	Laser Lite Corded Plug CL4 - SLC80 25dB(A)	Box/100Pr
EPC400LL1	Laser Lite Uncorded Refill Canister	Canister/400Pr

Honeywell X-treme® Tapered Earplugs



- Smooth tapered shape for easy insertion
- Brightly coloured, offering high visibility for worker compliance
- Polyurethane foam for comfort and high SLC80 ratings

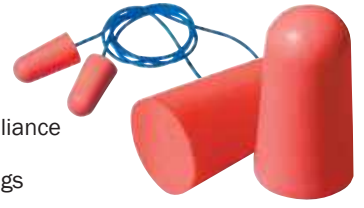

CODE	DESCRIPTION	UOM
EPXTR1	X-treme Uncorded CL5 - SLC80 26dB(A)	Box/200Pr
EPXTR30	X-treme Corded CL5 - SLC80 26dB(A)	Box/100Pr
EPC400XTR1	X-treme Uncorded Refill Canister	Canister/400Pr

Honeywell AirSoft® Reusable Earplugs



- Advanced air pocket design features internal noise blocking fins
- Rounded four flange profile
- Firm stem facilitates easy insertion and removal
- Supplied with storage case



CODE	DESCRIPTION	UOM
EPAS1	AirSoft Uncorded c/w Case CL5 - SLC80 26dB(A)	Box/50Pr
EPAS30R	AirSoft Corded c/w Case CL5 - SLC80 26dB(A)	Box/50Pr

Honeywell Quiet® Banded Aural Earplugs



- Patented band design prevents ear pods from touching contaminated surfaces
- Three ergonomic pod designs for maximum protection
- Replaceable PVC foam pods
- Lightweight & portable - designed for intermittent noise hazards

CODE	DESCRIPTION	UOM
EPQB1	QB1 Quiet Band CL2 - SLC80 16dB(A)	Ea
EPQB2	QB2 Quiet Band CL3 - SLC80 21dB(A)	Ea
EPQB3	QB3 Quiet Band CL3 - SLC80 20dB(A)	Ea

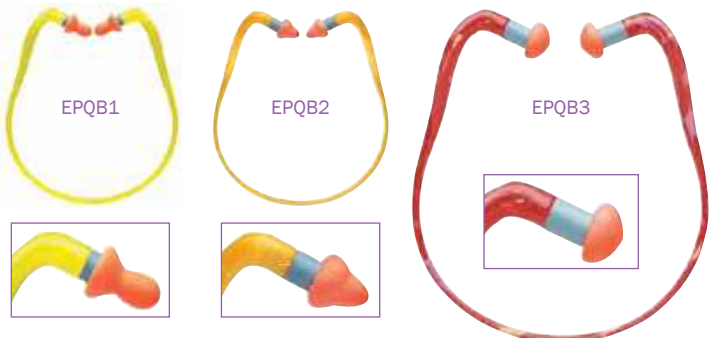

HOWARD LEIGHT earplugs are certified to AS/NZS 1270:2002



ProBullet™ Disposable Earplugs

- Brightly coloured HI VIS PU foam - bullet shape
- Single use disposable
- Corded and uncorded styles available
- Suitable for noise levels to 110dB(A)
- Dispenser packaging available



CODE	DESCRIPTION	UOM
EPOC	ProBullet Corded CL5 - SLC80 27dB(A)	Box/100Pr
EPOU	ProBullet Uncorded CL5 - SLC80 27dB(A)	Box/200Pr
EPDS500R	ProBullet Uncorded Dispenser Refill	Bag/500Pr
EPOU50	ProBullet Uncorded Dispenser Trade Pack	Pack/50Pr
EPDS500A	ProBullet Dispenser (Earplugs not included)	Ea



ProBell™ Disposable Earplugs

- Brightly coloured HI VIS PU foam - bell shape
- Single use disposable
- Corded and uncorded styles available
- Suitable for noise levels to 110dB(A)
- Dispenser packaging available



CODE	DESCRIPTION	UOM
EPYC	ProBell Corded CL5 - SLC80 27dB(A)	Box/100Pr
EPYU	ProBell Uncorded CL5 - SLC80 27dB(A)	Box/200Pr
EPYU500R	ProBell Uncorded Dispenser Refill	Bag/500Pr
EPDS500A	ProBell Dispenser (Earplugs not included)	Ea



ProBell™ Metal Detectable Earplugs

- Internal metal ball and blue colour for visual and automated inspections
- Detectable metallised cord
- Bell shape plug design for ease of insertion and fit
- Disposable PU foam in individual polybag



CODE	DESCRIPTION	UOM
EPBMDC	ProBell Metal Detectable CL5 - SLC80 27dB(A)	Box/100Pr



ProSil™ Reusable Earplugs

- Corded or uncorded options
- 3-flange design for fit and performance
- Reusable silicone material
- Resealable plastic case

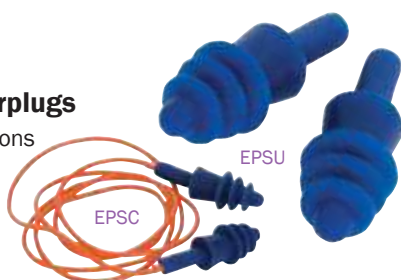

CODE	DESCRIPTION	UOM
EPSU	ProSil Uncorded CL3 - SLC80 18dB(A)	Pair
EPSC	ProSil Corded CL3 - SLC80 18 dB(A)	Pair



Python® Slimline HI VIS Earmuff Range

- High performance hearing protection
- Steel wire headband for strength and durability
- Padded foam headband minimises pressure
- Lightweight earcup with high quality ear cushions



CODE	DESCRIPTION	UOM
EMPYTS	Python Slimline HI VIS Headband CL5 - SLC80 31dB(A)	Ea
EMPYTNB	Python Slimline HI VIS Neckband CL4 - 23dB(A)	Ea
ECPYTS	Python Slimline HI VIS Cap Attachable CL5 - 31dB(A)	Ea
EMZHKPYT	Hygiene Kit	Ea



Viper® Universal Earmuff Range

- General purpose with three-position headband
- Low clamping force to minimise pressure
- Solid, lightweight earcup construction
- Cushioned headband for comfort
- Cap attachable option



CODE	DESCRIPTION	UOM
EMVIP	Viper Headband CL5 - SLC80 26dB(A)	Ea
ECVIP	Viper Cap Attachable CL5 - SLC80 26dB(A)	Ea
EMZHKVIP	Hygiene Kit	Ea



Adder Earmuff System

- Versatile earmuff system
- High performance wire headband earmuff
- Browguard protection
- Mesh or polycarbonate visor options



CODE	DESCRIPTION	UOM
EMADD	Adder Headband Earmuff - CL5 - 32dB(A)	Ea
VFEADDM	Adder Faceshield Earmuff Kit c/w Mesh Visor	Ea
VFEADDCE	Adder Faceshield Earmuff Kit c/w Polycarbonate Clear Visor	Ea



VeriShield™ 100 Series Earmuffs

- Designed to provide optimum comfort over long periods of use
- Large dimension range to fit a wide range of head sizes
- Wide cup opening - ideal for workers with larger ears, or who wear hearing aids
- Steel wire construction with padded headband and precision micro adjustments
- ABS moulded with internal baffle design for lighter weight, patent pending
- Unique memory foam ear cushions for greater comfort and attenuation
- Air Flow Control technology for optimum attenuation across all frequencies



EM120



EM120FHV

EM120N

CODE	DESCRIPTION	UOM
EM120	VeriShield VS120 Headband CL5 - 30dB(A)	Ea
EM120FHV	VeriShield VS120 Headband/Folding HV CL5 - 31dB(A)	Ea
EM120F	VeriShield VS120 Headband/Folding CL5 - 31dB(A)	Ea
EM120N	VeriShield VS120 Neckband CL5 - 27dB(A)	Ea
EC120H	VeriShield VS120 Cap Attachable CL5 - 28dB(A)	Ea
EMZHK12HK	VeriShield Hygiene Kit for VS120 Series	Ea



Mach™ 1 Earmuff

- Economical design
- Extremely lightweight construction
- Comfort for intermittent and long term wearers
- Dielectric design



CODE	DESCRIPTION	UOM
EM1010421	MACH 1 Headband CL4 - SLC80 25dB(A)	Ea



Impact Sport Earmuff

- Built-in directional microphones
- Amplifies low-level sound safely to 82dB
- Sleek low profile design
- Up to 350 hours battery life
- Automatic 4-hour shut-off
- AUX input



EMS1013530

CODE	DESCRIPTION	COLOUR	UOM
EMS1013530	Impact Sports Earmuff CL4 - SLC80 24dB(A)	Green	Ea
EMS1030942	Impact Sports Earmuff CL4 - SLC80 24dB(A)	Black	Ea



SYNC Electro FM Earmuffs

- 10 pre-set channels
- Combines passive hearing with sound amplification and FM radio (separate controls for sound amplification and radio volume)
- Enhances ambient sound to 85dB(A)
- Batteries included



EMS1030333



EMS1030334

CODE	DESCRIPTION	UOM
EMS1030333	SYNC Electro FM Radio Headband Earmuff CL5 - SLC80 26dB(A)	Ea
EMS1030334	SYNC Electro FM Radio Cap Attach Earmuff CL4 - SLC80 23dB(A)	Ea



Sync® Wireless Earmuff with Bluetooth®

- Bluetooth® connectivity
- Answer calls or stream information via mobile phone
- Robust boom microphone
- Lithium Ion battery 16+ hours
- Includes USB cord and wall charger



CODE	DESCRIPTION	UOM
EMS1053017	Sync Wireless Headband CL5 - SLC80 31dB(A)	Ea



SYNC Digital AM/FM Radio Stereo Earmuff

- 10 pre-set channels
- Digital tuning with LCD display
- AUX input to connect to MP3
- Includes 3.5mm cable
- Radio volume does not exceed 82dB(A)
- HI VIS green for extra visibility
- Batteries included



CODE	DESCRIPTION	UOM
EMS1030332	SYNC AM/FM Radio Headband Earmuff CL5 - SLC80 26dB(A)	Ea

HONEYWELL HOWARD LEIGHT earmuffs are certified to AS/NZS 1270:2002

3M PELTOR™

Extreme Earmuffs H10 Series

- High performance earmuff range
- Padded stainless steel headbands with 4-point suspension
- Liquid & foam filled cushions



CODE	DESCRIPTION	UOM
EMH10A	Peltor H10A Headband CL5 - SLC80 33dB(A)	Ea
EMH10B	Peltor H10B Neckband CL5 - SLC80 34dB(A)	Ea
ECH10P	Peltor H10P Cap Attach CL5 - SLC80 33dB(A)	Ea
EMZHY10	Hygiene Kit	Ea

3M PELTOR™

Select Earmuffs H9 Series

- Lightweight, comfortable and effective earmuff range
- Padded stainless steel headbands with 4-point suspension
- Liquid & foam filled cushions



CODE	DESCRIPTION	UOM
EMH9A	Peltor H9A Headband CL4 - SLC80 24dB(A)	Ea
EMH9B	Peltor H9B Neckband CL4 - SLC80 24dB(A)	Ea
ECH9P	Peltor H9P Cap Attach CL4 - SLC80 24dB(A)	Ea
EMZHY5	Hygiene Kit	Ea

3M PELTOR™

Deluxe Earmuffs H7 Series

- Protection for severe and high noise level areas
- Padded stainless steel headbands with 4-point suspension
- Liquid & foam filled cushions



CODE	DESCRIPTION	UOM
EMH7A	Peltor H7A Headband CL5 - SLC80 30dB(A)	Ea
EMH7B	Peltor H7B Neckband CL5 - SLC80 28dB(A)	Ea
EMH7F	Peltor H7F Folding CL5 - SLC80 31dB(A)	Ea
ECH7P	Peltor H7P Cap Attach CL5 - SLC80 30dB(A)	Ea
EMH7FHV	Peltor H7F Folding HI VIS CL5 - SLC80 31dB(A)	Ea
EMZHY7	Hygiene Kit	Ea

3M PELTOR™

Premium Earmuff X4 and X5 Series

- Lightweight, low profile earmuffs designed for protection against low level industrial noise and other loud sounds
- Electrically insulated wire headband



WS-CUSH Wireless Communication Accessory

- Bluetooth wireless technology
- Noise-cancelling microphone
- 8hrs talk/streaming time



CODE	DESCRIPTION	UOM
EMX4A	Peltor X4A Headband CL5 - SLC80 31dB(A)	Ea
EMX5A	Peltor X5A Headband CL5 - SLC80 35dB(A)	Ea
EMX4B	Peltor X4B Neckband CL5 - SLC80 27dB(A)	Ea
EMX5B	Peltor X5B Neckband CL5 - SLC80 31dB(A)	Ea
ECX4P	Peltor X4P Cap Attach CL5 - SLC80 27dB(A)	Ea
ECX5P	Peltor X5P Cap Attach CL5 - SLC80 31dB(A)	Ea
EMZWSCUSH	Peltor WS-CUSH Accessory	Ea

3M PELTOR™

Kids Earmuff H510K

- Small sized earmuff, specifically designed for children
- Attenuates harmful noise levels without shutting out other ambient sounds
- Recommended for use by children up to age 7
- Neon pink or neon green for high visibility and fun

CODE	DESCRIPTION	UOM
EMH5A:GR	Peltor Kids Earmuff H510K Neon Green	Ea
EMH5A:PK	Peltor Kids Earmuff H510K Neon Pink	Ea



3M™ PELTOR™ earmuffs are certified to AS/NZS 1270:2002

3M PELTOR™

Lite-Com™ Plus Headsets

- Designed for workers where communication is essential - hands free up to 1km
- 69 two-way radio channels, 121 sub-channels
- Sudden impulse noise at harmful levels are immediately attenuated
- Built in active-sound function so ambient sounds can be heard
- Separate PTT (push to talk) button for the auxiliary input, where a mobile phone, radio, or other audio source can be connected
- Rechargeable lithium-ion battery (approx. 20hrs use)



EMSH7A4310AZ

EMSH7P3E4310AZ

CODE	DESCRIPTION
EMSH7A4310AZ	Peltor Lite-Com Plus Headband CL5 - SLC80 32dB (A)
EMSH7B4310AZ	Peltor Lite-Com Plus Neckband CL5 - SLC80 30dB (A)
EMSH7P3E4310AZ	Peltor Lite-Com Plus Cap Attach CL5 - SLC80 27dB (A)

3M PELTOR™

ProTac™ III Level-Dependent Earmuffs

- Digital level-dependent function for ambient listening
- Standard headset for high attenuation - Slim headset for medium attenuation
- Voice guided menu system
- 3.5mm jack: listen only stereo input to connect to external devices
- Dual shell design to protect electronics
- Two AA batteries included (approx. 100hrs use)



EMS13H220A

EMS13H220P3E

CODE	DESCRIPTION
EMS13H220A	Peltor ProTac III Headband Slim CL5 - SLC80 26db(A)
EMS13H220P3E	Peltor ProTac III Cap Attach Slim CL4 - SLC80 24db(A)
EMS13H221A	Peltor ProTac III Headband STD CL5 - SLC80 30db(A)
EMS13H221P3E	Peltor ProTac III Cap Attach STD CL5 - SLC80 30db(A)

3M PELTOR™

WS ProTac™ XPI BlueTooth Headset Range

- Bluetooth 4.2 including MultiPoint
- MMI menu set-up for easier handling in daily operations
- Noise cancelling water resistant speech microphone - improved speech intelligibility and IP68 rated - supports VOX
- Support for Bluetooth A2DP, streaming (selectable in Set-up mode)
- Auto power off after 4 hrs of non use to save battery
- Low-battery warning
- New FLX2 accessory jack options



EMS15H7AWS6

EMS15H7P3EWS6

EMS15H7BWS6FLX2

CODE	DESCRIPTION
EMS15H7AWS6	Peltor WS PROTAC XPI Headband CL5 - SLC80 32dB(A)
EMS15H7P3EWS6	Peltor WS PROTAC XPI Cap Attach CL5 - SLC80 27dB(A)
EMS15H7AWS6FLX2	Peltor WS PROTAC XPI FLX2 Headband CL5 - SLC80 32dB(A)
EMS15H7BWS6FLX2	Peltor WS PROTAC XPI FLX2 Neckband CL5 - SLC80 29dB(A)
EMS15H7P3EWS6FLX2	Peltor WS PROTAC XPI FLX2 Cap Attach CL5 - SLC80 27dB(A)

3M PELTOR™

High Attenuation Standard Headsets

- Microphone/speaker system with excellent attenuation
- Optimised acoustic design for best possible sound quality and comfort
- Quick positioning, dynamic speech boom microphone with effective noise compensation for clear, reliable communication
- Beam mounted earphones for minimal resonance and distortion
- Stainless steel headband
- Fluid filled ear cushions
- Standard J11 connection (Nexus TP-120)



EMSMT7H79A

EMSMT7H79P3E

CODE	DESCRIPTION
EMSMT7H79A	Peltor High Attenuation Headband CL5 - SLC80 31dB(A)
EMSMT7H79B	Peltor High Attenuation Neckband CL5 - SLC80 26dB(A)
EMSMT7H79P3E	Peltor High Attenuation Cap Attach CL5 - SLC80 29dB(A)

3M PELTOR™

WorkTunes™ Pro Headsets

- High attenuating hearing protector
- FM or AM/FM radio headset with built-in antenna
- Auto power off after 4hrs non use
- Voice guided menu system
- Digital station search - stores up to 5 stations
- 3.5mm jack: listen-only stereo input to connect to external devices
- Two AA batteries included



EMSHRXS221A

EMSHRXS221P3E

CODE	DESCRIPTION
EMSHRXS221A	Peltor WorkTunes Pro Headband FM CL5 - SLC80 32db(A)
EMSHRXS221P3E	Peltor WorkTunes Pro Cap Attach AM/FM CL5 - SLC80 30db(A)

3M PELTOR™

ProTac™ Hunter & Shooter Headsets

- Digital level-dependent function for ambient listening
- Large user-friendly push buttons
- Dual shell design to protect electronics
- Stainless steel wire headband
- Voice guided menu system
- 3.5mm jack: listen-only stereo input to connect to external devices
- Two AA batteries included (approx. 100hrs use)



EMS13H223A

CODE	DESCRIPTION
EMS13H222A	Peltor ProTac Hunter Headband CL5 - SLC80 26db(A)
EMS13H223A	Peltor ProTac Shooter Headband CL5 - SLC80 32db(A)

3M™ PELTOR™ earmuffs are certified to AS/NZS 1270:2002

HEARING PROTECTION QUICK REFERENCE GUIDE

TYPE	CODE	DESCRIPTION	BRAND	CLASS	SLC80	WEIGHT (GRAMS)	CLAMPING FORCE (N)	PAGE
EARPLUGS	EPOU	UNCORDED PROBULLET	PRO CHOICE	5	27dB	-	-	22
	EPOC	CORDED PROBULLET	PRO CHOICE	5	27dB	-	-	22
	EPYC	CORDED PROBELL	PRO CHOICE	5	27dB	-	-	22
	EPYU	UNCORDED PROBELL	PRO CHOICE	5	27dB	-	-	22
	EPBMDC	CORDED PROBELL DETECTABLE	PRO CHOICE	5	27dB	-	-	22
	EP1300	UNCORDED SKULL SCREWS	3M E•A•R	5	27dB	-	-	20
	EP1301	CORDED SKULL SCREWS	3M E•A•R	5	27dB	-	-	20
	EPMAX1	UNCORDED MAX PLUG	HONEYWELL HOWARD LEIGHT	5	26dB	-	-	21
	EPMAX30	CORDED MAX PLUG	HONEYWELL HOWARD LEIGHT	5	26dB	-	-	21
	EPXTR1	UNCORDED X-TREME TAPERED PLUG	HONEYWELL HOWARD LEIGHT	5	26dB	-	-	21
	EPXTR30	CORDED X-TREME TAPERED PLUG	HONEYWELL HOWARD LEIGHT	5	26dB	-	-	21
	EPAS1	UNCORDED SAIR-SOFT REUSEABLE PLUG	HONEYWELL HOWARD LEIGHT	5	26dB	-	-	21
	EPAS30R	CORDED AIR-SOFT REUSEABLE PLUG	HONEYWELL HOWARD LEIGHT	5	26dB	-	-	21
	EP3121219	UNCORDED TAPERFIT II R PLUG	3M E•A•R	5	26dB	-	-	20
	EP3121221	UNCORDED TAPERFIT II PLUS PLUG	3M E•A•R	5	26dB	-	-	20
	EP3123224	CORDED TAPERFIT II PLUS PLUG	3M E•A•R	5	26dB	-	-	20
	EPLPF1	UNCORDED MAX LITE TAPERED PLUG	HONEYWELL HOWARD LEIGHT	4	25dB	-	-	21
	EPLPF30	CORDED MAX LITE TAPERED PLUG	HONEYWELL HOWARD LEIGHT	4	25dB	-	-	21
	EPLL1	UNCORDED LASER LITE PLUG	HONEYWELL HOWARD LEIGHT	4	25dB	-	-	21
	EPLL30	CORDED LASER LITE PLUG	HONEYWELL HOWARD LEIGHT	4	25dB	-	-	21
	EPLT30	CORDED LASER TRAK DETECTABLE PLUG	HONEYWELL HOWARD LEIGHT	4	25dB	-	-	21
	EP3121256	UNCORDED SUPERFIT REGULAR PLUG	3M E•A•R	4	24dB	-	-	20
	EP3121254	CORDED SUPERFIT REGULAR PLUG	3M E•A•R	4	24dB	-	-	20
	EP3121201	UNCORDED CLASSIC BARREL PLUG	3M E•A•R	4	23dB	-	-	20
	EP3121250	UNCORDED NEON PLUG	3M E•A•R	4	23dB	-	-	20
	EP3111251	CORDED NEON PLUG	3M E•A•R	4	23dB	-	-	20
EP3114106	CORDED DETECTABLE PLUG	3M E•A•R	4	23dB	-	-	20	
BANDED EARPLUGS	EP3111101	CORDED CLASSIC BARREL PLUG	3M E•A•R	3	21dB	-	-	20
	EP3213200	UNCORDED EXPRESS POD PLUG	3M E•A•R	3	19dB	-	-	20
	EP3212115	CORDED EXPRESS POD PLUG	3M E•A•R	3	19dB	-	-	20
	EP3404001	UNCORDED ULTRAFIT W CASE	3M E•A•R	3	18dB	-	-	20
	EP3404002	CORDED ULTRAFIT W CASE	3M E•A•R	3	18dB	-	-	20
	EP3404004	UNCORDED ULTRAFIT	3M E•A•R	3	18dB	-	-	20
	EPSU	UNCORDED PROSIL	PRO CHOICE	3	18dB	-	-	22
	EPSC	CORDED PROSIL	PRO CHOICE	3	18dB	-	-	22
	EP3222000	SWERVE BANDED COMFORT PODS	3M E•A•R	4	23dB	-	-	20
	EPQB2	QB2 QUIET BANDED PLUG	HONEYWELL HOWARD LEIGHT	3	21dB	-	-	21
	EP3222000	SWERVE BANDED FLEX28 PODS	3M E•A•R	3	20dB	-	-	20
	EPQB3	QB3 QUIET BANDED PLUG	HONEYWELL HOWARD LEIGHT	3	20dB	-	-	21
	EPQB1	QB1 QUIET BANDED PLUG	HONEYWELL HOWARD LEIGHT	2	16dB	-	-	21
	EARMUFFS	EMX5A	X5A HEADBAND MUFF	3M PELTOR	5	35dB	352	11.1
EMH10B		H10 SERIES NECKBAND MUFF	3M PELTOR	5	34dB	282	11.2	24
EMH10A		H10 SERIES HEADBAND MUFF	3M PELTOR	5	33dB	296	10.3	24
EMX5B		X5B NECKBAND MUFF	3M PELTOR	5	31dB	200	13	24
EMX4A		X4A HEADBAND MUFF BLACK	3M PELTOR	5	31dB	183	12	24
EMH7F		H7F SERIES FOLDING MUFF	3M PELTOR	5	31dB	236	10.6	24
EMH7FHV		H7F SERIES HI VIS FOLDING MUFF	3M PELTOR	5	31dB	236	10.6	24
EMPYTS		PYTHON SLIMLINE HEADBAND MUFF	PRO CHOICE	5	31dB	366	12.5	22
EM120FHV		VERISHIELD VS120 FOLDING MUFF HV	HONEYWELL HOWARD LEIGHT	5	31dB	227	11.3	23
EM120F		VERISHIELD VS120 FOLDING MUFF	HONEYWELL HOWARD LEIGHT	5	31dB	227	11.3	23
EMH7A		H7 SERIES HEADBAND MUFF	3M PELTOR	5	30dB	216	12.9	24
EM120		VERISHIELD VS120 HEADBAND MUFF	HONEYWELL HOWARD LEIGHT	5	30dB	191	10.2	23
EMH7B		H7 SERIES NECKBAND MUFF	3M PELTOR	5	28dB	202	11.9	24
EM120N		VERISHIELD VS120 NECKBAND MUFF	HONEYWELL HOWARD LEIGHT	5	27dB	169	12.3	23
EMX4B		X4B NECKBAND MUFF	3M PELTOR	5	27dB	222	12.2	24
EMVIP		VIPER HEADBAND MUFF	PRO CHOICE	5	26dB	210	10.8	22
EM1010421		MACH 1 HEADBAND MUFF	HONEYWELL HOWARD LEIGHT	5	25dB	136	7.2	23
EMH9B		H9 SERIES NECKBAND MUFF	3M PELTOR	4	24dB	139	12.2	24
EMH9A		H9 SERIES HEADBAND MUFF	3M PELTOR	4	24dB	150	10.8	24
EMPYTNB		PYTHON SLIMLINE NECKBAND MUFF	PRO CHOICE	4	23dB	255	14.4	22
CAP ATTACHED EARMUFFS	ECH10P	H10P SERIES CAP ATTACH MUFF	3M PELTOR	5	33dB	320	9.1	24
	ECPYTS	PYTHON SLIMLINE CAP ATTACH	PRO CHOICE	5	31dB	301	13	22
	ECX5P	X5P CAP ATTACH MUFF BLACK	3M PELTOR	5	31dB	353	10.5	24
	ECH7P	H7P SERIES CAP ATTACH MUFF	3M PELTOR	5	30dB	240	11.0	24
	EC120H	VERISHIELD VS120CAP ATTACH MUFF	HONEYWELL HOWARD LEIGHT	5	28dB	195	10.5	23
	ECX4P	X4P CAP ATTACH MUFF	3M PELTOR	5	27dB	238	10.2	24
	ECVIP	VIPER CAP ATTACH MUFF	PRO CHOICE	5	26dB	223	9.4	22
	ECH9P	H9P SERIES CAP ATTACH MUFF	3M PELTOR	4	24dB	177	11.2	24



RESPIRATORY PROTECTION

APPLICATION

An employer is required to demonstrate compliance to AS/NZS 1715 or any of the legislated Codes of Practice in terms of risk management. It is also an employer responsibility to ensure other means of hazard control have been investigated prior to introducing respiratory protection initiatives.

RISK ASSESSMENT

The AS/NZS 1715:2009 describes respiratory risk assessment along with a Respiratory Protection Programme and the appointment of a Programme Administrator where respiratory protective equipment (RPE) is required to be worn. Some of the risk assessment requirements are:

- Ensure the workplace is not a confined space. This can only be determined by measurement of the risk atmosphere for safe oxygen levels throughout the working period. Negative pressure respiratory protection cannot supplement oxygen.

FILTER CLASSES & IDENTIFICATION

TYPE	COLOUR	APPLICATION	PROTECTION LEVEL (NEGATIVE PRESSURE)*		WHEN TO CHANGE
			HALF FACE	FULL FACE	
PARTICLE FILTERS			For levels up to:		
P1	White	Mechanically generated particles	10 x WES	N/A	Particulate filters should be changed when unacceptable breathing resistance is experienced or in accordance with a locally specified change schedule.
P2	White	Mechanically/thermally generated particles	10 x WES	50 x WES	
P3	White	Toxic & mechanically/thermally generated particles	10 x WES	100 x WES	
GAS & VAPOUR FILTERS			Whichever level is lower of:		
A1	Brown	Organic gases/vapours with boiling points > 65°C	10 x WES or 1000ppm	50 x WES or 1000ppm	Charcoal filters should be changed when breakthrough/smell/taste is detected or in accordance with a locally specified change schedule.
A2	Brown	Organic gases/vapours with boiling points > 65°C	10 x WES or 1000ppm	100 x WES or 5000ppm	
AX	Brown	Organic gases/vapours with boiling points < 65°C	N/A	50 x WES or 5000ppm	
B1	Grey	Inorganic gases/vapours	10 x WES or 1000ppm	50 x WES or 1000ppm	
E1	Yellow	Acid gases	10 x WES or 1000ppm	50 x WES or 1000ppm	
K1	Green	Ammonia & ammonia derivatives	10 x WES or 300ppm	300ppm	Note: Ammonia has an IDLH value of 300ppm and filtering respirators should not be used above this concentration.

This guide is based on AS/NZ 1715:2009 with specific reference to tables 4.3, 4.4 and 4.5

WES = Workplace Exposure Standard - see Safework Australia website <http://hcis.safeworkaustralia.gov.au/ExposureStandards>

Additional filter types are available for specific chemicals.

Combination filters have the same limitations as for each component.

*Note: protection levels for PAPR and face/head top combinations may vary.

- Evaluate tasks to determine if RPE will compromise vision, communications or other PPE.
- The employer must provide training in the cleaning, safe use and limitations of RPE at the commencement of employment.
- The Programme Administrator must ensure a compliant fit test has been carried out for all users of RPE and maintain suitable records. The AS/NZS 1715:2009 describes both Qualitative and Quantitative fit test methods.

SAFETY TIPS

- Facial hair has the potential to compromise the face seal of respirators - being clean shaven is best!
- Consider the impacts of other forms of PPE.
- Keep RPE in optimum condition for best performance.
- Store RPE in a clean/dry condition and away from harmful atmospheres.
- Inspect RPE before use and check performance.

All workers should be trained in the correct use and maintenance of personal protective equipment.

USEFUL REFERENCES

AS/NZS 1715:2009 Selection, use and maintenance of respiratory protective equipment.

AS/NZS 1716:2012 Respiratory protective devices.

DISPOSABLE RESPIRATORS	28
HALF & FULL FACE RESPIRATORS	30
PAPR UNITS	33
AIRLINE & SCBA	36
GAS DETECTION	38



P2 Disposable Respirators

- P2 rating for protection against mechanically and thermally generated particles
- Latex free dual straps for a firm, comfortable fit
- Moulded nose piece for better fit and close seal
- Exhalation ProValve option for extra air flow
- Internal flange for a perfect seal
- Colour coded valves (where fitted) and packaging
- Also available in Valved Carbon Filter
- TGA approved



RD4036



RD4037



RD4057

CODE	DESCRIPTION	UOM
RD4036	ProChoice P2 Cup Respirator	Box/20
RD4037	ProChoice P2 Valved Cup Respirator	Box/12
RD4057	ProChoice P2 Valved & Active Carbon Filter Cup Respirator	Box/12



P2 ProMesh Disposable Respirators

- P2 rating for protection against mechanically and thermally generated particles
- Flexible mesh for optimum shape retention
- Moulded nose piece for close fit
- Quick lock straps for easy fit and release
- Exhalation ProValve option for extra air flow
- Also available in Valved Carbon Filter



RD3821



RD3822



RD3823

CODE	DESCRIPTION	UOM
RD3821	ProMesh P2 Cup Respirator	Box/12
RD3822	ProMesh P2 Valved Cup Respirator	Box/12
RD3823	ProMesh P2 Valved & Active Carbon Filter Cup Respirator	Box/12



P1 Disposable Respirators

- P1 rating for protection against mechanically generated particles
- Latex free dual straps for a firm, comfortable fit
- Colour coded nose pieces, valves (where fitted) and packaging
- Exhalation ProValve option for extra air flow



RD4031



RD4035

CODE	DESCRIPTION	UOM
RD4031	ProChoice P1 Cup Respirator	Box/20
RD4035	ProChoice P1 Valved Cup Respirator	Box/12



P2 Horizontal Flat Fold Respirators

- P2 rating for protection against mechanically and thermally generated particles
- Exhalation valve for extra comfort
- Dual straps to give firm and comfortable fit
- RD2122 has aluminium-free nose clip to reduce risk of ignition
- RD2132 has mouldable foam nose piece for contoured fit



RD2122



RD2132

CODE	DESCRIPTION	UOM
RD2122	ProChoice P2 Horizontal Flat Fold Valved Respirator	Box/12
RD2132	ProChoice P2 Horizontal Flat Fold Valved Respirator	Box/10



FilterSpec™ PRO P2 Goggle/Mask Combo

- A goggle and mask in one
- Anti-fog, anti-scratch, medium impact protection lens, certified to AS/NZS 1337.1:2010
- Mask certified to AS/NZS 1716:2102 Lic 1508, P2 rating plus protection against nuisance-level organic vapours
- Can be worn over most prescription eyewear



CODE	DESCRIPTION	UOM
VGCFSPG	FilterSpec PRO P2 Goggle/Mask Combo c/w Three Filters	Ea
RDFSPG531	FilterSpec PRO P2 Replacement Mask with Carbon Filter	Box/10

PROCHOICE respirators meet the performance requirements of AS/NZS 1716:2003



VFlex™ N95 Disposable Respirator

- Folded v-shaped pleats that expand, giving you a spacious feel and flex with mouth movement
- Side tabs act as handles to aid in positioning of the respirator
- Adjustable, embedded metal nose clip helps provide a custom and secure seal



CODE	DESCRIPTION	UOM
RD1804	VFlex™ N95 Particulate Respirator 1804, Standard Size	Box/50
RD1804S	VFlex™ N95 Particulate Respirator 1804S, Small Size	Box/50



Acid Gas/Organic Vapour P1 Disposable Respirators

- Activated carbon layer helps reduce exposure to nuisance levels* of acid gas or organic vapour and odour
- P1 rated filter protects against dusts, mists and fumes
- 3M™ Cool Flow™ exhalation valve option to reduce heat build-up
- Robust shell and cup design
- Mouldable nose clip for a better seal and fit - reduces eyewear fogging



CODE	DESCRIPTION	UOM
RD9916	Acid Gas Respirator 9916 P1 Valved	Box/10
RD9913V	Organic Vapour Respirator 9913V GP1 Valved	Box/10
RD9913	Organic Vapour Respirator 9913 GP1	Box/15



Maintenance-Free Reusable Half Face 4000+ Series Respirator

- Enhanced exhalation valve assembly reduces breathing resistance by over 30%
- Ready-to-use with integrated filters
- Resealable bag provides hygienic storage and longer filter life
- Low-profile and ergonomic design



CODE	DESCRIPTION	UOM
RHF4251	Respirator 4251+ A1P2	Ea
RHF4255	Respirator 4255+ A2P2	Ea
RHF4277	Respirator 4277+ A1B1E1P2	Ea
RHF4279	Respirator 4279+ A1B1E1K1P2	Ea



Qualitative Fit Testing Kit

- Easy to use method for performing qualitative fit testing
- Kit contains a hood and collar assembly, sensitivity solution, test solution, 2 nebulisers & instructions
- Available with: FT-10 Sweet (Saccharin) and FT-30 Bitter (Bitrex) solutions



CODE	DESCRIPTION	UOM
RZFT10	FT-10 Qualitative Fit Test Apparatus Kit - Sweet (Saccharin)	Ea
RZFT30	FT-30 Qualitative Fit Test Apparatus Kit - Bitter (Bitrex)	Ea



9300+ Aura™ Series Disposable Respirators

- Ingenious 3-panel collapse resistant design provides better fit
- 3M™ high performance filter media for low breathing resistance and comfortable wear
- 3M™ Cool Flow™ valve on RD9312 and RD9322 respirators reduces heat and moisture build-up
- New embossed top panel reduces fogging of eyewear
- Individually packaged for easy storage and dispensing



RD9322



RD9320



RD9312



RD9310

CODE	DESCRIPTION	UOM
RD9322	Flat Fold Respirator 9322A+ P2 Valved	Box/10
RD9320	Flat Fold Respirator 9320A+ P2	Box/20
RD9312	Flat Fold Respirator 9312A+ P1 Valved	Box/10
RD9310	Flat Fold Respirator 9310A+ P1	Box/20



8000 Classic Series Disposable Respirators

- Staple-free: features welded straps
- Mould nose clip to the wearer's nose shape to help reduce eyewear fogging and for a better seal and fit
- Natural rubber latex free
- 3M™ Cool Flow™ exhalation valve option to help remove your hot exhaled air for a cooler and drier wear



RD8822



RD8210



RD8812



RD8710

CODE	DESCRIPTION	UOM
RD8822	Cupped Respirator 8822 P2 Valved	Box/10
RD8210	Cupped Respirator 8210 P2	Box/20
RD8812	Cupped Respirator 8812 P1 Valved	Box/10
RD8710	Cupped Respirator 8710 P1	Box/20

Sundström

SR100 Half Face Respirator & Kits

RHFK6211

- Premium silicone face piece
- Single filter design for simple use and maintenance
- Twin exhalation valves
- Baffles for dust and mist protection
- V-shaped adjustable elastic head harness
- Can be fitted with SR307 airline attachment
- Additional sizes available in some kits



RHF100
(FILTER SOLD SEPARATELY)

CODE	DESCRIPTION	SIZE
RHF100	Sundström SR100 Half Face Respirator	S/M, M/L, L/XL
RHFK5482	Sundström Asbestos Kit c/w SR100 Half Face Respirator and P3 Filter	M/L
RHFK6211	Sundström Silica Dust Kit c/w SR100 Half Face Respirator and P3 Filter	M/L
RHFK5465	Sundström Pro Kit c/w SR100 Half Face Respirator and A1B1E1 Filter	M/L
RHFK6339	Sundström Premium Kit c/w SR100 Half Face Respirator and A1P3 Filter	M/L

Sundström Respirator Accessories



RFZ307

RHZ905

RHZ02820

RFZ05776

CODE	DESCRIPTION	UOM
RFZ307	Sundström SR307 Airline Attachment	Ea
RHZ905	Sundström SR905 Remote Filter Holder with Twin Hose	Ea
RHZ02820	Sundström Storage Box for Half Face Respirators SR100 / SR90-3 / SR90	Ea
RFZ05776	Sundström Storage Box for SR200 Full Face Respirator	Ea

Sundström Filter Selection Guide



CODE	RF510	RF217	RF218	RF315	RF294	RF297	RF299	RF316	RF295	RFP221
TYPE	P2/P3*	A1	A2	A1B1E1	A2B2E2	A1B1E1K1	A1B1E1K1HgP3	K1	K2	Pre-Filter
APPLICATION	Solid & liquid hazardous particles such as dusts, mists, smoke, fumes, bacteria and viruses.	Gases and vapours from organic compounds with boiling point >65°C.		Organic, inorganic and acidic gases & vapours.		Organic, inorganic and acidic gases & vapours including ammonia and specific amines.	Organic, inorganic and acidic gases & vapours including ammonia, specific amines, mercury & particulates.	Ammonia and certain amines.		Sorts out coarse wet & dry particles, protects the main filter and prolongs its service life.
UOM	Each	Each		Each		Each	Each	Each		Each
COLOUR										

* P2 when used with SR100, SR90/3 and SR900 and P3 when used with SR200 Full Face Respirator.

Sundström

SR900 Half Face Respirator & Kits

RHFK6152

- Thermoplastic elastomer face piece
- Two exhalation valves
- Detachable filter holder which enables connection to SR905 remote filter holder, PAPR units or compressed air attachment
- Respirator available in 3 sizes



RHF900

CODE	DESCRIPTION	SIZE	UOM
RHF900	Sundström SR900 Half Face Respirator	S, M, L	Ea
RHFK6152	Sundström Basic Box c/w SR900 Half Face Respirator and A1 Filter	M	Ea
RHFK6153	Sundström Basic Box c/w SR900 Half Face Respirator and ABEK1 Filter	M	Ea

Sundström

SR200 Full Face Respirator & Kit

RFF200C
(FILTER SOLD SEPARATELY)

- Lightweight 450gms silicone face seal
- Polycarbonate lens
- Cloth head harness
- Twin exhalation valves for minimum exhalation resistance
- Can be fitted with SR307 compressed airline attachment



RFFK5947

CODE	DESCRIPTION	SIZE	UOM
RFF200C	Sundström SR200 Full Face Respirator	One Size	Ea
RFFK5947	Sundström Kit c/w SR200 Full Face Respirator and A1B1E1K1 Filter	One Size	Ea

SUNDSTRÖM respirators meet the performance requirements of AS/NZS 1716:2012



6000 Series Half Face Respirator & Kits

- Lightweight elastomeric face piece
- Low profile and well balanced twin filter design
- Cradle head harness and easy to fasten neck strap
- Incorporates the 3M™ Bayonet Connection System for filter attachment



RHF6228

RHF6000: FILTERS SOLD SEPARATELY

CODE	DESCRIPTION	SIZE	UOM
RHF6000	3M Half Face Respirator 6000 Series	S, M, L	Ea
RHFK6228	3M Welding Respirator Kit c/w 6000 Series Half Face Respirator and GP2 Filters	M	Ea
RHFK6251	3M Spraying Respirator Kit c/w 6000 Series Half Face Respirator and A1P2 Filters	S, M, L	Ea
RHFK6225	3M Dust/Particle Respirator Kit c/w 6000 Series Half Face Respirator and P2 Filters	S, M, L	Ea
RHFK6259	3M Multi-Gas Respirator Kit c/w 6000 Series Half Face Respirator and A1B1E1K1P2 Filters	S, M, L	Ea



7500 Series Half Face Respirator & Kits

- Soft silicone for comfort and durability
- Low profile, well-balanced twin filter design
- 3M™ Cool Flow™ Exhalation valve helps reduce fogging when wearing eye protection
- Ideal for working in hot, humid conditions or during prolonged use



RHF7551

RHF7500: FILTERS SOLD SEPARATELY

CODE	DESCRIPTION	SIZE	UOM
RHF7500	3M Half Face Respirator 7500 Series	S, M, L	Ea
RHFK7528	3M Welding Respirator Kit c/w 7500 Series Half Face Respirator and GP2 Filters	M	Ea
RHFK7551	3M Spraying Respirator Kit c/w 7500 Series Half Face Respirator and A1P2 Filters	S, M, L	Ea
RHFK7535	3M Asbestos/Dust Respirator Kit c/w 7500 Series Half Face Respirator and P2 Filters	S, M, L	Ea



6500QL Series Half Face Respirator & Kits

- Comfortable silicone face seal
- Low profile design for compatibility
- Convenient Quick Latch mechanism for easy donning and doffing
- 3M™ Cool Flow™ valve helps reduce heat and moisture build-up
- 3M™ bayonet connection for compatibility with all bayonet style 3M™ cartridges



RHF6551

RHF6500QL

CODE	DESCRIPTION	SIZE	UOM
RHF6500QL	3M Half Face Respirator 6500QL	S, M, L	Ea
RHFK6528	3M Welding Respirator Kit c/w 6500QL Series Half Face Respirator and GP2 Filters	S, M, L	Ea
RHFK6535	3M Construction Respirator Kit c/w 6500QL Series Half Face Respirator and P2/P3 Filters	S, M, L	Ea
RHFK6551	3M Spraying Respirator Kit c/w 6500QL Series Half Face Respirator and A1P2 Filters	S, M, L	Ea



6000 Series Full Face Respirator & Kits

- Lightweight elastomeric face piece
- Simple and easy to use
- Polycarbonate lens, molten metal and high impact resistant
- Low profile and well-balanced twin filter design



RFF6835

RFF6000: FILTERS SOLD SEPARATELY

CODE	DESCRIPTION	SIZE	UOM
RFF6000	3M Full Face Respirator 6000 Series	S, M, L	Ea
RFF6835	3M Asbestos/Dust Full Face Respirator Kit c/w RFF6000, P3 Filters, Earplugs, Wipes	S, M, L	Ea
RFF6851	3M Spraying+/Painting Respirator Kit c/w RFF6000, A1P2 Filters, Earplugs, Wipes	S, M, L	Ea



Filters for 6000 & 7500 Series Respirators



RFX501 RETAINER

CODE	RF2125	RF2128	RF2138	RF5925	RF6051	RF6057	RF6059
TYPE	P2	GP2	GP2/GP3**	P2	A1	A1B1E1	A1B1E1K1
APPLICATION	Certain dusts, mists and fumes such as sanding, grinding, cutting, drilling metal, masonry, wood and concrete.	Welding fumes, ozone, polishing and grinding particles. Also for spraying pesticides or herbicides with vapour pressure <1.3 Pa @ 25°C.	Toxic particulates, nuisance level* acid gas and organic vapours with low vapour pressure.	Dusts and mists, including those containing oil. For use with the 6000 series cartridges. Requires RFX501 retainer (ordered separately).	Organic solvents (boiling point >65°C) eg. toluene and MEK. Also degreasing, mixing, using paint thinner, lacquers and glues.	Organic vapours (boiling point >65°C), inorganic & acid gases.	Multi-gas; Organic vapours (boiling point >65°C), inorganic & acid gases, ammonia, methylamine.
UOM	Pack/2	Pack/2	Pack/2	Box/5Pr	Pack/2	Pack/2	Pack/2
COLOUR							

* Not to be used when spraying isocyanate based paints.

* Nuisance levels are those levels below the Workplace Exposure Standards.

** Higher P3 protection factors only achieved with a 3M Full Face Respirator, otherwise P2 protection level when worn on a 3M Half Face Respirator.

3M respirators meet the performance requirements of AS/NZS 1716:2012



Secure Click™ HF-800SD Series Half Mask Reusable Respirator

- Next generation comfort, breathability and simplicity
- Patented silicone flex-joint face seal
- Unique filter click connection
- Dual-flow filters with 4 airflow paths
- Swept back filter design
- Speaking diaphragm
- Push button seal check



CODE	DESCRIPTION	SIZE	UOM
RHF800SD	3M Secure Click™ Half Mask Respirator	S, M, L	Ea

3M Gas & Vapour Filters



CODE	RF8051	RF8055	RF8059	RF8094	RF8095
TYPE	A1	A2	A1B1E1K1	A1B1E1K1P3*	A2P3*
APPLICATION	Organic gases/vapours with boiling points > 65°C	Organic gases/vapours with boiling points > 65°C	Organic gases/vapours with boiling points > 65°C, inorganic gases/vapours, acid gases, ammonia & ammonia derivatives	Organic gases/vapours with boiling points > 65°C, inorganic gases/vapours, acid gases, ammonia & ammonia derivatives, toxic & mechanically/thermally generated particles	Organic gases/vapours with boiling points > 65°C, toxic & mechanically/thermally generated particles
UOM	Pack/4 Pair	Pack/4 Pair	Pack/4 Pair	Pack/4 Pair	Pack/4 Pair
COLOUR					

3M Replaceable Particulate Filters



CODE	RFX701
DESCRIPTION	Filter Retainer for RF7925/7935. Suitable for use in environments containing solid and liquid particles
UOM	Each

3M Particulate Filters



CODE	RF3125	RF3128	RF3135	RF3138
TYPE	P2	P2 with Nuisance Level Organic Vapour/Acid Gas	P3*	P3* with Nuisance Level Organic Vapour/Acid Gas
APPLICATION	Mechanically/thermally generated particles	Mechanically/thermally generated particles, nuisance level* acid gas and organic vapours with low vapour pressure	Toxic & mechanically/thermally generated particles	Toxic & mechanically/thermally generated particles, nuisance level* acid gas and organic vapours with low vapour pressure
UOM	Pack/10 Pair	Pack/10 Pair	Pack/10 Pair	Pack/10 Pair



CODE	RF7925	RF7935
TYPE	P2	P3*
APPLICATION	Mechanically/thermally generated particles	Toxic & mechanically/thermally generated particles
UOM	Pack/20 Pair	Pack/20 Pair

* Higher P3 protection factors only achieved with a 3M Full Face Respirator, otherwise P2 protection level when worn on a 3M Half Face Respirator.

3M respirators meet the performance requirements of AS/NZS 1716:2012



Aviva40 Half Face Respirator & Ready-Paks

- Soft, flexible TPE
- Hybrid reflex face seal
- Easy to use leak check mechanism
- Single filter half mask utilising the Pro2000 range of filters
- Goggle pinch improved eyewear PPE integration
- Ready-Pak option for clean storage and easy transportation



RHF8000645



RHF800500

CODE	DESCRIPTION	SIZE	UOM
RHF800500	3M Aviva40 Half Face Respirator	S, M, L	Ea
RHF8000643	3M Aviva40 Asbestos/Dust Ready-Pak c/w Aviva40 Half Face Respirator and PF10 P2 Filter	S, M, L	Ea
RHF8000645	3M Aviva40 Spraying Ready-Pak c/w Aviva40 Half Face Respirator and c/w A2P2 Filter	S, M, L	Ea



FM3 Promask PAPP Full Face Mask & Proflow SC 160 ReadyPak

- Slimline halo-butyl face piece with polycarbonate visor
- Approval rating PAPP P3
- ReadyPak includes:
 - FM3 Promask
 - Proflow SC 160 PAPP Unit
 - Battery and charger,
 - EPDM hose
 - Two Pro2000 P3 filters
 - Storage container
- Battery time is typically 6-7 hours for a single charge



RPFK5064594



RPF1268

CODE	DESCRIPTION	SIZE	UOM
RPF1268	3M FM3 Promask Full Face (Use with SC 160)	S, M/L	Ea
RPFK5064594	3M Proflow SC 160 FM3 Promask ReadyPak c/w P3 Filters	M/L	Ea



Pro2000 DIN Filters



CODE	RF052670	RF042670	RF042671	RF042674	RF042799	RF052691	RFX052692
TYPE	PF10 P3*	CF22 A2P3R*	CF22 B2P3R*	CF22 A2B2P3*	CF32 A2B2E2K2P3*	Pre-Filter	Pre-Filter Holder Kit
APPLICATION	Solid/liquid particulates, radioactive/toxic particles, bacteria, viruses, fumes/mists.	Organic gases & vapours (with boiling point >65°C), solid/liquid particles. For use with Proflow SC 120 only.	Inorganic gases & vapours eg. formaldehyde, solid & liquid particles. For use with Proflow SC 120 only.	Organic, inorganic gases & vapours, solid & liquid particles. For use with Proflow SC 120 only.	Organic/inorganic & acid gases/vapours, ammonia & ammonia derivatives, solid/liquid particles. For use with Proflow SC 120 only.	Protects the main filter against early clogging by larger particles.	Pre-filter kit for Pro2000 filters (includes two holders and six pre-filters).
UOM	Each	Each	Each	Each	Each	Pack/20	Each
COLOUR							

*Note: The particulate rating on the above filters is P2 when worn with half mask respirators as shown.

3M Versaflo™ PAPR Headtops



- RPH133**
 - PETG visor with polypropylene hood
 - Integrated harness
 - General purpose
- RPH333**
 - Polycarbonate visor with polypropylene hood
 - Integrated harness
 - General purpose
- RPH433**
 - PETG visor with polypropylene hood
 - Neck/shoulder coverage
 - Integrated harness



- RPF206 / RPF207 (FR FACE SEAL)**
 - High impact visor
 - Dust, spraying, chemicals and silica stone cutting/grinding/polishing
- RPF306**
 - High impact visor & helmet
 - Dust, spraying & chemicals
 - Hard hat rated
- RPF406 / RPF407 (FR FACE SEAL)**
 - High impact visor & helmet with neck/shoulder protection
 - Dust, spraying & chemicals

3M Versaflo™ TR-600 PAPR Headtop Kits

- Kits include selected headtop, TR-602E turbo unit, standard battery, charger, tube and P3 filter & filter cover



RPFKTR6M307

CODE	DESCRIPTION	UOM
RPFKTR6M307	Versaflo™ TR-600 Kit c/w M-307FR Helmet	Ea
RPFKTR6M407	Versaflo™ TR-600 Kit c/w M-407FR Helmet	Ea

3M Versaflo™ TR-300+ PAPR Headtop Kits

- Kits include selected headtop, TR-302E turbo unit, standard battery, charger, tube and P3 filter & filter cover



RPHKTRS433C

CODE	DESCRIPTION	UOM
RPHKTRS333C	Versaflo™ TR-300 Kit c/w S-333 Headcover	Ea
RPHKTRS433C	Versaflo™ TR-300 Kit c/w S-433 Headcover	Ea
RPFKTRM206C	Versaflo™ TR-300 Kit c/w M-206 Faceshield	Ea
RPFKTRM306C	Versaflo™ TR-300 Kit c/w S-306 Helmet	Ea
RPFKTRM406C	Versaflo™ TR-300 Kit c/w M-406 Helmet	Ea

3M Jupiter™ PAPR Headtop Kits

- Kits include selected headtop, Jupiter turbo unit, standard belt, battery, charger, tube and P3 filter & filter cover





RPFK9020381

CODE	DESCRIPTION	UOM
RPFK9020381	Jupiter™ Kit c/w M-206 Faceshield	Ea
RPFK9020393	Jupiter™ Kit c/w M-207 Faceshield FR Face Seal	Ea
RPFK9020382	Jupiter™ Kit c/w M-306 Helmet	Ea
RPHK9020337	Jupiter™ Kit c/w S-133 Headcover	Ea
RPHK9020343	Jupiter™ Kit c/w S-433 Headcover	Ea

3M Versaflo™ TR-600 PAPR Unit & Filters



CODE	RF6600	RF6580	RF6310	RF6820
TYPE	Pre-Filter*	A1B1E1HgP3	A1P3	P3+ Nuisance Odour
UOM	Each	Each	Each	Each
COLOUR				

* Specific pre-filter holders required for each filter - additional filter options available

CODE	DESCRIPTION	UOM
RPPKTR619A	Versaflo Turbo Starter Kit c/w TR-602E Turbo/Battery/Charger/P3/Cover/Tube/Belt	Ea
RPX20	BT-20 Standard Breathing Tube 735mm	Ea

3M Versaflo™ TR-300 PAPR Unit & Filters





CODE	RF3600	RF3712E	RF3802E	RF3822E
TYPE	Pre-Filter	P3	P3 + Nuisance Organic Vapour	P3 + Nuisance Acid Gas
UOM	Each	Each	Each	Each
COLOUR				

CODE	DESCRIPTION	UOM
RPPKTR315A	Versaflo Turbo Starter Kit c/w TR-302E Turbo/Battery/Charger/P3/Cover/Tube/Belt	Ea
RPX30	BT-30 Standard Breathing Tube 735mm	Ea

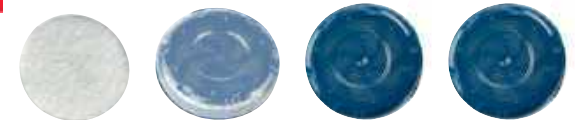
3M Jupiter™ PAPR Unit & Filters



CODE	RF4610002P24	RF4500025	RF4530025	RF4530925
TYPE	Pre-Filter	P3	A1P3	A1B1E1K1P3 PAPR
UOM	Pack/24	Pair	Pair	Pair
COLOUR				

CODE	DESCRIPTION	UOM
RPP9020179	Jupiter Turbo c/w Turbo/Battery	Ea
RPZ0030058	Jupiter Battery Charger	Ea
RPX20	BT-20 Standard Breathing Tube 735mm	Ea

RESPIRATORY PROTECTION

CleanSpace
RESPIRATORS

CleanSpace2™ Power System



- Includes power unit, filter, charger, harness, neck pads, flow test cap and storage bag
- Powerful micro-turbine motor delivers positive pressure to mask ensuring high level of protection
- Battery life typically >6 hrs
- Ratchet adjustment for close and comfortable fit

CleanSpace
RESPIRATORS

CleanSpace™ EX Power System



- Intrinsically safe, certified for use in potentially explosive atmospheres
- Includes power unit, filter, charger, harness, neck pads, flow test cap and storage bag
- Powerful micro-turbine motor delivers positive pressure to mask and P3 TM3 protection levels
- Battery life approx. 8hrs
- Ratchet adjustment for close and comfortable fit

CleanSpace
RESPIRATORS

CleanSpace™ ULTRA Power System



- Rating IP66 for use in decontamination showers
- Includes power unit, filter, charger, harness, neck pads, flow test cap and storage bag
- Powerful micro-turbine motor delivers positive pressure to mask ensuring high level of protection
- Battery life approx. 8hrs
- Ratchet adjustment for close and comfortable fit

CODE	DESCRIPTION
RPP0034	CleanSpace2™ PAPR Power System

CODE	DESCRIPTION
RPP0060	CleanSpace™ EX PAPR Power System

CODE	DESCRIPTION
RPP0070	CleanSpace™ ULTRA PAPR Power System

CleanSpace
RESPIRATORS

Powered Air Respirator Half Face Mask

- Low profile design ensures maximum visibility and awareness for the wearer
- Clear, hygienic and washable medical grade silicone
- Neck mounted with no cables or hoses for high mobility
- Simple clip enables mask to be easily changed between wearers
- High quality exhalation valve - easy to breathe and talk
- Compatible with many forms of head and face protection
- Available in 3 sizes



MASK SHOWN WITH PAPR POWER UNIT

CODE	DESCRIPTION	SIZES
RPH0033	CleanSpace™ Half Mask	S, M, L

CleanSpace
RESPIRATORS

Powered Air Respirator Full Face Mask

- Soft, hygienic, non allergenic medical grade silicone face mask
- 5 point head harness with neck mounting - no cables or hoses for high mobility
- Simple clip enables mask to be easily changed between wearers
- Easily removed oronasal inner mask
- Available in two sizes: S and M/L



MASK SHOWN WITH PAPR POWER UNIT

CODE	DESCRIPTION	SIZES
RPF1014	CleanSpace™ Full Face Mask	S, M/L

CleanSpace
RESPIRATORS

Filters



CODE	RF0035	RF0036	RF0037	RF0076	RF0091	RF0057	RPX0038
TYPE	P3	Particulate Pre-Filter	P3	A1B1E1K1P3	A1B1E1P3	Pre-Filter	Filter Adaptor
APPLICATION	Solid and liquid particulates including dusts, mists, fumes, fibres, bacteria and viruses.	Flame retardant pre-filter, extends the life of the CleanSpace2™ particulate filters.	Solid and liquid particulates including dusts, mists, fumes, fibres, bacteria and viruses.	Organic/ inorganic & acid gases/vapours, ammonia & ammonia derivatives, solid/ liquid particles.	Organic gases & vapours, inorganic gases, vapours & acid gases, solid/ liquid particles.	Designed to remove coarse particles and enhance the life of the Particulate P3 Filter.	Adaptor - for CleanSpace2™ PAPR Unit Gas & P3 High Capacity Filters.
UOM	Pack/3	Pack/10	Each	Each	Each	Pack/20	Each
COLOUR							

CleanSpace™ respirators meet the performance requirements of AS/NZS 1716:2012

Sundström PAPR SR500& SR700 Kits

SR900 Half Face Mask

- Thermoplastic elastomer face piece
- Two exhalation valves for minimum exhalation resistance
- 2 sizes available (M, L)

PICTURED WITH SR952 HOSE



SR200 Full Face Mask

- Lightweight 450gms silicone face seal
- Twin exhalation valves
- Polycarbonate lens
- Cloth head harness

PICTURED WITH SR550 HOSE



SR570 Supplied-Air Face Shield

- Quick-release hose connection
- New adjustable head harness
- Flip-up visor
- Super-flex breathing hose
- Internal airflow deflection

INCLUDES SR571 HOSE



SR700 Fan Unit

- Standard battery: 8 hours (normal)
- Complete with belt and charger
- Includes 2x SR510 filters, 10x pre-filters, 2x filter adaptors, 2x pre-filter holders



SR500 Fan Unit

- Standard battery: 8 hours (normal)
- Complete with belt and charger
- Includes 2x SR510 filters, 10x pre-filters, 2x filter adaptors, 2x pre-filter holders









CODE	DESCRIPTION
RPHK06000	Kit c/w SR700 Fan Unit, SR900 Half Face Mask & SR952 Hose
RPFK05667	Kit c/w SR700 Fan Unit & SR200 Full Face Mask & SR550 Hose
RPFK06162	Kit c/w SR700 Fan Unit & SR570 Face Shield & SR571 Hose

CODE	DESCRIPTION
RPHK06024	Kit c/w SR500 Fan Unit, SR900 Half Face Mask & SR952 Hose
RPFK05004	Kit c/w SR500 Fan Unit & SR200 Full Face Mask & SR550 Hose
RPFK06161	Kit c/w SR500 Fan Unit & SR570 Face Shield & SR571 Hose

Sundström Filter Selection



CODE	RF510	RF710	RF518	RF515	RF597	RF599	RFP221
TYPE	P3	P3	A2	A1B1E1	A1B2E2K1	A1B2E2K1HgP3	Pre-Filter
UOM	Each	Each	Each	Each	Each	Each	Each
COLOUR							

CAN ONLY BE USED WITH SR500

SUNDSTRÖM respirators meet the performance requirements of AS/NZS 1716:2012

Honeywell

Airvisor MV Refinishers Kit Supplied Air Respirator

- Disposable fabric face skirt cassette
- Additional spray gun hose assembly
- Clear acetate visor
- Includes waist belt with airflow regulator
- AS/NZS 1716:2003



CODE	DESCRIPTION	UOM
RAH0201	Honeywell Airvisor MV Refinishers Kit	Ea
RAX1504	Acetate Visor	Ea
RAX1507	Peel Off Visors	Pk/10

Honeywell

Airvisor MV Industrial Kit Supplied Air Respirator

- Disposable fabric face skirt cassette
- Clear polycarbonate visor
- Includes waist belt with airflow regulator
- AS/NZS 1716:2003



CODE	DESCRIPTION	UOM
RAH0203	Honeywell Airvisor MV Industrial Kit	Ea
RAX1503	Polycarbonate Visor	Ea

Honeywell

Spray Painters Kit

- Complete respiratory protective system - ideal for applying two-pack paint
- Supplied with airvisor, 7.5m auxiliary air hose for spray tool, waist belt regulator and Clearflow II wallmount filter
- 2 person combination filter set including airline fittings
- Kit is packed in a reusable plastic storage container
- Optional airline hose lengths: 3.5m, 7.5m, 15m, 30m



CODE	DESCRIPTION	UOM
RAHK100SPW	Honeywell Spray Painters Kit	Ea
RAX1404	Carbon Cartridge for Waistbelt Regulator	Ea
RAXAH150C	Airline Hose 15m	Ea



Promask Combi Airline Mask

- Constant flow compressed airline system
- Halo-butyl face piece
- Polycarbonate visor
- Includes airline hose with self-closing hose connector
- Can be used with Pro2000 filters
- Requires RAX2017250 regulator



AIRLINE REGULATOR

Scott™ Airline Regulator

- Waist-mounted control valve for use with a medium pressure compressed airline system
- Adjustable airflow to the respirator
- For use with 3M Promask Combi

CODE	DESCRIPTION	SIZE	UOM
RAF12781	Promask Combi Airline Mask c/w Hose	M/L	Ea
RAF5012674	Promask Combi Airline Mask c/w Hose	S	Ea
RAX062580	Control Valve c/w Belt	-	Ea



PVC Airline Hose

- Durable, black PVC airline hose
- CEJN double action airline fittings
- Certified to AS/NZS 1716:2012



CODE	DESCRIPTION	UOM
RAXAH10C	10m PVC Airline Hose c/w Fittings	Ea
RAXAH20C	20m PVC Airline Hose c/w Fittings	Ea
RAXAH30C	30m PVC Airline Hose c/w Fittings	Ea



Flite COV Airline Breathing Apparatus

- Bandolier harness with padded shoulder strap
- Optional 10 or 15 minute air supply
- Requires 3M Promask full face mask
- Switchover to emergency cylinder air supply is immediately activated when primary air supply is interrupted
- Warning whistle informs user when cylinder air in use



CODE	DESCRIPTION	UOM
RAB2030177	Flite COV Bandolier	Ea
RAF013190	Promask PP LQF Full Face Mask	Ea
RAC2031535	Flite 200 BAR 10min. Steel Cylinder c/w Hose & Pouch	Ea
RAC2031537	Flite 200 BAR 15min. Steel Cylinder c/w Hose & Pouch	Ea



ELSA Escape Breathing Set

- Rechargeable 15 min cylinder breathing set
- Adjustable shoulder strap
- Automatic activation upon opening the carry bag - delivers constant flow of air
- Integrated warning whistle on low air condition
- Cubic hood design allows wearing by users with beards



CODE	DESCRIPTION	UOM
RSK2009419	ELSA Escape Unit c/w 15min. Cylinder	Ea



M206 HEADTOP



Versaflor™ Air Supply Respirator Kits

- Kits include selected faceshield head top with V-500E air regulator & breathing tube
- V-500E has locking adjustment knob and integrated low air flow warning whistle, silencer, replacement carbon filter, auxiliary port and user instructions

CODE	DESCRIPTION	UOM
RAF9020384	Versaflor M-206 Faceshield & Belt Regulator Airline Spray Painters Kit	Ea
RAF9020386	Versaflor M-406 Faceshield c/w Shroud & Belt Regulator Airline Kit	Ea
RAX9020217	Versaflor V-500E Airline Regulator c/w Breathing Tube	Ea



Airline Filter

- Designed to be installed directly at point of use
- Two types of filtration:
 - Oil vapours
 - Liquid aerosols & solid particles



CODE	DESCRIPTION	UOM
RABA21BOPT	Airline Filter Regulator - 2 Person	Ea



RSKCOMP6T2

Sigma 2 Type 2 SCBA Compliance Set

- Designed for marine, industrial, confined space entry, rescue or industrial firefighting
- Compact first breath activated demand valve with bypass - approx. 45min. duration
- Ergonomically designed lightweight backplate and Type 2 harness
- Kevlar® blend flame retardant webbing with Kevlar® cylinder band
- Certified to AS/NZS 1716:2012 and EN137:2006 Type 2 MED

CODE	DESCRIPTION	UOM
RSKCOMP6T2	Sigma 2 Type 2 SCBA Compliance Set	Ea
RSB2023034	Sigma 2 Type 2 SCBA Backplate/Harness/Pneumatics	Ea
RAF013190	Promask PP LQF Full Face Mask	Ea
RSC1118245T	Carbon Fibre 6.8L 300 BAR Cylinder	Ea

Honeywell

GasAlertMicroClip XL/X3 Series Detectors & Kits

- Honeywell BW™ MicroClip X3 for extended reliability with 3-year warranty
- Honeywell BW™ MicroClip XL for standard operation with 2-year warranty
- Guaranteed to run an entire shift, even at -20 °C
- IP68 rating - unmatched water protection
- Compact, lightweight and easy to use - with one-button operation and no extensive training
- Device management with Honeywell Safety Suite
- Flashing green IntelliFlash™ light for compliance at a glance
- Reflex™ Technology ensures sensor responsiveness for safety, uptime and worker confidence protection



H₂S CO O₂ LEL

CODE	DESCRIPTION
RGMMCXLYAU	MicroClip XL 4-Gas Detector LEL/O ₂ /H ₂ S/CO Yellow
RGMCX3YAU	MicroClip X3 4-Gas Detector LEL/O ₂ /H ₂ S/CO Yellow
RGMKMCXK1STD	MicroClip XL 4-Gas Detector Kit LEL/O ₂ /H ₂ S/CO Yellow
RGMKMCX3STD	MicroClip X3 4-Gas Detector Kit LEL/O ₂ /H ₂ S/CO Yellow

Honeywell

BW™ ICON Four Gas Detector

- Fixed-life, 2-year, 4-gas detector for the gas hazards that workers face most often
- Simple icon display for gas levels/device status including 2 bell icons for gas alarms and indicators next to sensor for fast decision making
- Easy to use: one-button operation
- Small, lightweight and wearable
- The latest in low power LEL infrared technology with no sensor poisoning
- No service required: activate and use for two years
- Bluetooth included for ease of downloading and sending reports via the Safety Suite App
- 2 months of battery runtime on a 4.5-hour charge (up to 4 months if you turn off the detector at the end of each shift)
- Compatible with IntelliDoX instrument management system and Honeywell Device Configurator App



CODE	DESCRIPTION
RGMICONH	BW Icon (O ₂ , LEL IR, H ₂ S, CO) Yellow or Black
RGMICONS	BW Icon (O ₂ , LEL, H ₂ S, SO ₂) Yellow or Black
RGXCOMP01MC5	5-Way Cradle Charger for BW Icon and BW Flex

Honeywell

IntelliDoX Automated Instrument Management System

- Industry-leading fast bump test that eliminates bottlenecks, while avoiding costly purge cycles that waste gas
- Gangable up to five modules, each with its own LCD screen and keypad for independent operation
- Easy to connect via ethernet to a network
- USB port to easily configure dock module settings or retrieve data without network access
- Automated bump test and span calibration operation
- Device management with Honeywell Safety Suite
- Bump testing, calibration, configuration, and record-keeping support for compatible detectors
- User updatable settings
- Requires Enabler Kit

CODE	DESCRIPTION
RGZDXULTRA	IntelliDOX Docking Station for BW Ultra
RGZDXBWC4	IntelliDOX Docking Station for BW Clip4
RGZDXMCLP	IntelliDOX Docking Station for GasAlertMicroClip

CODE	DESCRIPTION
RGZDXSOLO	IntelliDOX Docking Station for BW Solo
RGZDXENBLAU	Enabler Kit



Honeywell

BW™ Ultra Multi-Gas Detector

- Tamper-proof operation with one-button operation
- Intuitive LCD icons for quick decision making
- Easy service and maintenance
- IntelliFlash™ and also Reverse IntelliFlash™ for clear compliance
- Scratch-resistant display protector
- Honeywell Connected Worker compatible
- Honeywell TouchConnect™ Technology for activating a feature
- Honeywell SafetySuite for unit configuration and reporting
- Ergonomically designed for easy use
- Quick bump & calibration with IntelliDoX system



H₂S CO O₂ LEL VOC CO₂ SO₂ NH₃ H₂ Cl₂ NO₂ HCN NO

CODE	DESCRIPTION
RGMULTRA100YA	Ultra 4-Gas Detector O ₂ /LEL/H ₂ S/CO
RGMULTRA1Q1YA	Ultra 5-Gas Detector O ₂ /LEL/H ₂ S/CO/VOCS
RGMULTRA1B1YA	Ultra 5-Gas Detector O ₂ /LEL/H ₂ S/CO/CO ₂ IR
RGMULTRA1S1YA	Ultra 5-Gas Detector O ₂ /LEL/H ₂ S/CO/SO ₂

Honeywell

BW™ Solo Serviceable Single Gas Detector

- The easiest single-gas detector to service
- Complete with an extensive selection of sensor options
- The first single-gas detector with the 1-Series sensor for CO, H₂S and O₂
- Compatible with IntelliDoX: save time and centralize data with automated bump testing, calibration and instrument management
- Use IntelliDoX docking stations with Honeywell SafetySuite Device Configurator software



H₂S CO O₂ NH₃ SO₂ HCN Cl₂ NO NO₂ PH₃ ETO ClO₂ O₃ H₂

CODE	DESCRIPTION
RGMSOLOHLY	BW Solo H ₂ S Standard Yellow
RGMSOLOMLY	BW Solo CO Standard Yellow
RGMSOLOSAY	BW Solo NH ₃ Standard Yellow
RGMSOLOZY	BW Solo HCN Standard Yellow



WORK WEAR

APPLICATION

When engineering and administrative control measures are unable to reduce exposure to hazards that may impact the torso of the body, employees should be supplied with, and wear effective workwear. This will include the ability to see a worker in all light conditions.

RISK ASSESSMENT

The process of carrying out a risk assessment should include a site survey that identifies workplace activities, lists the hazards present and assesses the level of risk that needs to be covered through the provision of protective clothing.

Determining the level of protection required should include which parts of the body require protection, the type of protection and with reference to appropriate standards should they exist.

Research should be carried out to identify products that provide the required level of protection and should be supported with appropriate documentation and product labelling. Specific attention should be given to the functionality of garments that are multi-layered or are worn in conjunction with other types of PPE.

Wearer trials are an important part of the evaluation process and obtaining wearer feedback is critical to ensure product suitability. Issues relating to sizing, ease of maintenance and durability are important factors.

HIGH VISIBILITY

AS/NZS 4602.1:2011 specifies garment parameters for high visibility clothing where high risk applications exist. These design requirements are structured around the needs of road and rail traffic workers. However, it is often recommended that workers in industrial workplaces with similar risk factors adopt this standard.

Specific garment design may vary depending on the workplace environment such as weather, type of work being undertaken and comfort considerations.

Garment Classifications:

The garments specified in this Standard are classified as follows:

- (a) Class D - A garment designed for daytime use.
- (b) Class N - A garment designed for night use using retroreflected light.
- (c) Class D/N - A garment designed for day and night use.

USEFUL REFERENCES

AS/NZS 4501 Set:2008 Occupational protective clothing Set.

AS/NZS 4602.1:2011 High visibility safety garments Part 1: Garments for high risk applications

AS/NZS 4399:1996 Sun protective clothing - Evaluation and classification.

SUN PROTECTION

AS/NZS 4399 sets out requirements for determining the rated ultraviolet protection factor of fabrics used for sun protection garments and other items of personal apparel (such as hats) which are worn in close proximity to the skin. It also specifies appropriate detailed labelling requirements.



Protection ratings:

- UPF 15, 20** Good Protection
- UPF 25, 30, 35** Very Good Protection
- UPF 40, 45, 50** Excellent Protection

Note: UPF ratings should not be confused with Sun Protection Factor (SPF) ratings which are not applicable to textiles.

SAFETY TIPS

- Ensure protective clothing is maintained with instructions to ensure optimum performance.
- Where possible select HI VIS colours that contrast to the prevailing background in the work area.
- Garments should be critically examined at 3-6 month intervals for damage, excessive fading, or the retroreflective material has ceased to be fit for purpose.
- Procedures covering the handling of contaminated clothing should be established eg. toxic chemicals & dusts.

All workers should be trained in the correct use and maintenance of personal protective equipment.

SHIRTS	40
TROUSERS	42
SPECIALTY RANGES	43
WOMEN'S WORKWEAR	47
OUTDOOR	48
POLAR FLEECE	53
POLO SHIRTS	54

Cool Lightweight Drill Shirts



Cool Lightweight Taped HI VIS Shirt

- 100% cotton preshrunk drill - 155gsm
- Full gusset sleeve cuff
- Vertical back & underarm cotton mesh ventilation
- Two chest pockets with button-down flaps
- 3M™ 8910 reflective tape
- AS/NZS 4602.1:2011 Class D/N

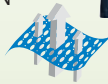

*Refer to inside back cover for details

CODE	COLOURS	SIZES
WBS6896T	Yellow/Navy, Orange/Navy, Yellow/Green	XS - 6XL
WBS6896TP	Pink/Navy - NBCF Logo*	S - 6XL



Cool Lightweight Taped HI VIS Shirt

- 100% cotton preshrunk drill - 155gsm
- Two button adjustable sleeve cuff
- Vertical back & underarm cotton mesh ventilation
- Two chest pockets with button-down flaps
- 3M™ 8910 reflective tape
- AS/NZS 4602.1:2011 Class D/N



*Refer to inside back cover for details

CODE	COLOURS	SIZES
WBS6696T	Yellow/Navy, Orange/Navy, Yellow/Royal, Yellow/Charcoal, Yellow/Khaki, Lime/Charcoal	S - 6XL
WBS6696TP	Yellow/Pink, Orange/Pink - NBCF Logo*	S - 6XL



Cool Lightweight Shoulder Taped HI VIS Shirt

- 100% cotton preshrunk drill - 155gsm
- Vertical back & underarm cotton mesh ventilation
- Two chest pockets with button-down flaps
- 3M™ 8910 reflective tape
- AS/NZS 4602.1:2011 Class D/N

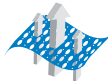

CODE	COLOURS	SIZES
WBS6432T	Yellow/Navy, Orange/Navy	S - 6XL



Cool Lightweight HI VIS Shirts

- 100% cotton preshrunk drill - 155gsm
- Vertical back & underarm cotton mesh ventilation
- Two chest pockets with button-down flaps
- AS/NZS 4602.1:2011 Class D

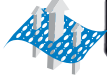

CODE	DESCR.	COLOURS	SIZES
WBS1895	Short Sleeve	Yellow/Navy, Orange/Navy, Yellow/Green	XS - 6XL
WBS6895	Long Sleeve	Yellow/Navy, Orange/Navy, Yellow/Green	XS - 6XL



Cool Lightweight Taped HI VIS Shirt

- 100% cotton preshrunk drill - 155gsm
- Vertical back & underarm cotton mesh ventilation
- Two chest pockets with button-down flaps
- 3M™ 8910 reflective tape
- AS/NZS 4602.1:2011 Class D/N

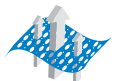

CODE	COLOURS	SIZES
WBS6897T	Orange	XS - 6XL



Cool Lightweight Shirts

- 100% cotton preshrunk drill - 155gsm
- Vertical back & underarm cotton mesh ventilation to help keep you cool
- Two chest pockets with button-down flaps

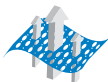

CODE	DESCRIPTION	COLOURS	SIZES
WBS1893	Short Sleeve	Navy, Khaki	S - 6XL
WBS6893	Long Sleeve	Navy, Khaki	S - 6XL



Taped Biomotion Cool Lightweight HI VIS Shirt

- 100% cotton preshrunk drill - 155gsm
- Reflective tape hoop pattern around body
- Over the shoulder tape with bio-motion taping around sleeves
- Cotton mesh back & underarm ventilation
- Two button adjustable sleeve cuff
- AS/NZS 4602.1:2011 Class D/N



CODE	COLOURS	SIZES
WBS6016T	Orange	S - 6XL



Taped X Back Biomotion Cool Lightweight HI VIS Shirt

- 100% cotton preshrunk drill - 155gsm
- Perforated reflective tape H pattern around body
- X back with biomotion taping around sleeves
- Cotton mesh back & underarm ventilation
- Two button adjustable sleeve cuff
- AS/NZS 4602.1:2011 Class D/N



CODE	COLOURS	SIZES
WBS6166XT	Orange	XS - 6XL

Regular Weight Drill Shirts



Regular Weight Taped HI VIS Shirt

- 100% cotton preshrunk drill - 190gsm
- Two chest pockets with button-down flaps
- 3M™ 8910 reflective tape
- Two button adjustable sleeve cuffs
- AS/NZS 4602.1:2011 Class D/N



CODE	COLOURS	SIZES
WBS6456T	Yellow/Navy, Orange/Navy, Yellow/Green	S - 6XL



Regular Weight Shoulder Taped HI VIS Shirt

- 100% cotton preshrunk drill - 190gsm
- Two chest pockets with button-down flaps
- 3M™ 8910 reflective tape
- Two button adjustable sleeve cuffs
- AS/NZS 4602.1:2011 Class D/N



CODE	COLOURS	SIZES
WBS6267T	Yellow/Navy, Orange/Navy	S - 6XL



Regular Weight Taped Closed Front HI VIS Shirt

- Half closed button front placket
- 100% cotton preshrunk drill - 190gsm
- Two chest pockets with button-down flaps
- 3M™ 8910 reflective tape
- Two button adjustable sleeve cuffs
- AS/NZS 4602.1:2011 Class D/N



CODE	COLOURS	SIZES
WBS6456T	Yellow/Navy, Orange/Navy	S - 6XL

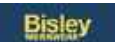

Regular Weight HI VIS Shirt Long Sleeve

- 100% cotton pre-shrunk drill - 190gsm
- Two chest pockets with button-down flaps
- Two button adjustable sleeve cuffs
- AS/NZS 4602.1:2011 Class D



CODE	COLOURS	SIZES
WBS6267	Yellow/Navy, Orange/Navy, Yellow/Green	XS - 6XL



Regular Weight Closed Front HI VIS Shirt

- Half closed button front placket
- 100% cotton preshrunk drill - 190gsm
- Two chest pockets with button-down flaps
- Two button adjustable sleeve cuffs
- AS/NZS 4602.1:2011 Class D



CODE	COLOURS	SIZES
WBS6267	Yellow/Navy, Orange/Navy, Yellow/Green	S - 6XL



Regular Weight HI VIS Shirt Long Sleeve

- 100% cotton preshrunk drill - 190gsm
- Two chest pockets with button-down flaps
- Two button adjustable sleeve cuffs
- Open and closed front styles available
- AS/NZS 4602.1:2011 Class D



CODE	DESCR.	COLOURS	SIZES
WBS6339	Open Front	Orange	S - 6XL
WBS6433	Closed Front	Orange	S - 6XL



Regular Weight Shirt Short Sleeve

- 100% cotton preshrunk drill - 190gsm
- Two chest pockets with button-down flaps
- Two button adjustable sleeve cuffs
- Open and closed front styles available



CODE	DESCR.	COLOURS	SIZES
WBS1433	Open Front	Navy, Khaki, Green, Black	S - 6XL
WBS6433	Closed Front	Navy, Khaki, Green	



Regular Weight Shirt Long Sleeve

- 100% cotton preshrunk drill - 190gsm
- Two chest pockets with button-down flaps
- Two button adjustable sleeve cuffs
- Open and closed front styles available



CODE	DESCR.	COLOURS	SIZES
WBS6433	Open Front	Khaki, Navy, Green, Black	S - 6XL
WBS6433	Closed Front	Khaki, Navy, Green, Royal	S - 6XL, XS - 6XL

Drill, Denim Work Trousers



Original Cotton Drill Work Trousers

- 100% cotton preshrunk drill - 310gsm
- Single front pleats
- Mobile phone pocket
- YKK® zipper

AS/NZS 4602.1:

2011 taped option:

- 3M™ 8910 reflective tape Class:
- Orange D/N
- Navy N



CODE	DESCR.	COLOURS	SIZES
WBT6007	Untaped	Navy, Khaki, Green	77 - 112R, 87 - 132S, 74 - 94L
WBT6007T	Taped	Navy, Orange	



Original Cotton Drill Cargo Trousers

- 100% cotton preshrunk drill - 310gsm
- Adjustable side tabs on waistband
- 8 pocket cargo design
- YKK® zipper

AS/NZS 4602.1:

2011 taped option:

- 3M™ 8910 reflective tape Class N



CODE	DESCR.	COLOURS	SIZES
WBT6007	Untaped	Navy, Khaki, Green, Black	77 - 112R, 87 - 132S, 74 - 94L
WBT6007T	Taped	Navy	



Rough Rider Denim Jean

- 100% cotton stone-wash denim - 465gsm
- Classic 5 pocket styling
- Double stitched seams
- YKK® zipper

AS/NZS 4602.1: 2011 taped option:

- 3M™ 8910 reflective tape Class N



CODE	DESCR.	COL.	SIZES
WBT6050	Untaped	Denim	77 - 112R, 92 - 132S, 74 - 94L
WBT6050T	Taped	Denim	



Taped Biomotion Cotton Drill Trousers

- 100% cotton preshrunk drill - 310gsm
- 3M™ biomotion tape around upper and lower leg
- Standard or cargo pocket options
- YKK® zipper

AS/NZS 4602.1: 2011 taped option:

- 3M™ 8910 reflective tape Class N



CODE	DESCR.	COLOURS	SIZES
WBT6003T	Original	Navy	77 - 112R, 92 - 132S
WBT6003T	Cargo	Navy	



Taped Biomotion Stretch Cotton Drill Cargo Trousers

- 97% cotton, 3% elastane cotton drill - 280gsm
- Stretch reflective tape with biomotion configuration
- Modern fit, slim straight leg
- Stretch mid-rise fit
- Curved waistband
- Multi-functional pockets
- Bisley Fresche® bacterial treatment to prevent odour



CODE	COLOURS	SIZES
WBT6008T	Navy	77 - 112R, 87 - 132S, 74 - 94L



Permanent Press Trousers

- 65% polyester/ 35% viscose gaberdine - 235gsm
- Dupont™ Stain ReGuard finish
- Single pleat front
- Easy fit adjustable waist
- 5 pocket styling
- YKK® zipper



CODE	COLOURS	SIZES
WBT6123	Navy, Black	77 - 112R, 87 - 132S



Cool Lightweight Utility Trousers

- 100% cotton preshrunk drill - 240gsm
- Eyelet ventilation between legs
- Double layered knee
- Utility pocket on right hand side
- Cargo pocket with gusset on left hand side
- YKK® zipper



CODE	DESCR.	COLOURS	SIZES
WBT6999	Untaped	Navy, Khaki, Green, Black	77 - 112R, 87 - 132S, 74 - 94L
WBT6999T	Taped	Navy	



Cool Lightweight Work Trousers

- 100% cotton preshrunk drill - 190gsm
- Eyelet ventilation between legs
- Double layered knee
- Utility pocket on right hand side
- Cargo pocket with gusset on left hand side
- YKK® zipper



CODE	COLOURS	SIZES
WBT6899	Navy	77 - 112R, 87 - 132S, 74 - 94L

Bisley
WORKWEAR

Double HI VIS

- AS/NZS 4602.1: 2011
- Taped options: Class D/N
- Non taped: Class D



Taped Mesh Polo - Short Sleeve

- 100% polyester mesh - 130gsm
- Contrast HI VIS accents
- Perforated tape



Taped Mesh Polo - Long Sleeve

- 100% polyester mesh - 130gsm
- Contrast HI VIS accents
- Biomotion taping on sleeves



Taped Softshell Jacket

- 100% polyester mechanical stretch twill/bonded fleece - 310gsm
- Contrast HI VIS accents
- Biomotion taping on sleeves



Short

- 65% polyester/35% cotton twill - 245gsm
- Contrast HI VIS accents
- Mobile phone pocket



Taped Biomotion Pant

- 65% polyester/35% cotton twill - 245gsm
- Contrast HI VIS accents
- Mobile phone pocket

CODE	DESCR.	COLOURS	SIZES	CODE	DESCRIPTION	COLOURS	SIZES	CODE	DESCR.	COLOURS	SIZES
WBP1223T	Polo S/S	Yellow/Orange	XS - 6XL	WBJ6222T	Softshell Jacket	Yellow/Orange	XS - 6XL	WBT6411T	Biomotion Pant	Yellow/Orange	72 - 112R
WBP6223T	Polo L/S	Orange/Yellow	XS - 6XL	WBD1411	Short	Orange/Yellow	72 - 132			Orange/Yellow	87 - 132S

Bisley
WORKWEAR

Shorts



Original Work Short

- Cotton preshrunk drill - 310gsm
- Single pleat front
- Mobile phone pocket



Utility Short

- Cotton preshrunk drill - 240gsm
- Eyelet leg ventilation
- Cargo pocket



Cargo Short

- Cotton preshrunk drill - 310gsm
- 8 pocket cargo style
- Adjustable waist side tabs



Cool Vented Lightweight Cargo Short

- Cotton preshrunk drill - 190gsm
- 11 pocket cargo style
- Gusset ventilation

CODE	DESCRIPTION	COLOURS	SIZES	CODE	DESCR.	COLOURS	SIZES
WBD1007	Work Short	Navy, Khaki, Green	77 - 132	WBDC1007	Cargo Short	Navy, Khaki, Green, Black	77 - 132
WBD1999	Utility Short	Navy, Khaki, Green, Black	77 - 132	WBD1431	Vented Cargo	Navy	77 - 132

Bisley
WORKWEAR

Overalls

- 100% cotton preshrunk drill
- Front press stud fastening
- Double layered knee
- Various pocket configurations depending on style
- AS/NZS 4602.1: 2011:
 - 3M 8910 reflective tape Class D/N
 - Non taped 2-Tone HI VIS Class D



WBO0007



WBO6007



WBO6357



WBO6719T



WBO0359T

CODE	DESCRIPTION	COLOURS	SIZES	CODE	DESCRIPTION	COLOURS	SIZES
WBO0007	310gsm Action Back Overall	Navy		WBO6719T	190gsm Two-Tone Taped Coverall	Yellow/Navy, Orange/Navy	77 - 117R, 92 - 132S, 74 - 94L
WBO6007	310gsm Coverall	Navy	77 - 117R, 92 - 132S, 74 - 94L	WBO0359T	310gsm Two-Tone Taped Action Back Overall	Yellow/Navy, Orange/Navy	77 - 117R, 92 - 132S
WBO6357	310gsm Two-Tone Coverall	Yellow/Navy, Orange/Navy					

Flex & Move™ Range



Flex & Move™ Mechanical Stretch Shirts

- 100% cotton twill - 145gsm
- Mechanical stretch fabric for extra comfort and movement
- Two button adjustable sleeve cuff
- Contrast polyester patches
- 3M™ reflective piping
- Two chest pockets with touch tape closure



CODE	DESCRIPTION	COLOURS	SIZES
WBS1133	Short Sleeve	Black , Charcoal	XS - 6XL
WBS6133	Long Sleeve	Black , Charcoal	Active Fit



Flex & Move™ X Taped HI VIS Utility Shirts

- 98% cotton/2% spandex poplin - 145gsm
- Stretch cotton poplin fabric for extra comfort and movement
- Perforated reflective tape
- Fabric pre-rinse washed for worn in look
- AS/NZS 4602.1:2011 Class D/N



BACK

CODE	DESCR.	COLOURS	SIZES
WBS1177XT	Short Sleeve	Yellow/Navy,	XS - 6XL
WBS6177XT	Long Sleeve	Orange/Navy	Active Fit



Flex & Move™ Utility Work Shirts

- 98% cotton/ 2% spandex poplin - 145gsm
- Stretch cotton poplin fabric for extra comfort and movement
- Multi-functional utility inspired chest pockets
- Enzyme washed to create worn-in look



CODE	DESCR.	COLOURS	SIZES
WBS1144	Short Sleeve	Navy, Black, Stone, Charcoal	XS - 6XL
WBS6144	Long Sleeve		Active Fit



Flex & Move™ Cotton Hoodie Tee

- 100% cotton jersey - 160gsm
- 3 button placket with contrast tipping
- Contrast lined hood with draw cord
- Double layer sleeve opening
- Chest welt pocket



CODE	COLOURS	SIZES
WBP6220	Blue, Charcoal, Green, Grey	XS - 6XL Active Fit



Flex & Move™ Puffer Fleece Hooded Jacket

- 100% nylon oxford - 136gsm
- Contrast poly/cotton knit fleece sleeves & hood
- Quilted with polyester wadding for extra warmth
- Adjustable lined quilted hood
- Two waist pockets with zip closure



CODE	COLOURS	SIZES
WBJ6944	Black	XS - 6XL Active Fit



Flex & Move™ Stretch Cargo Short

- 100% cotton duck weave canvas - 265gsm
- Curved waistband to prevent gaping
- 6 pocket styling
- YKK® zipper
- Contrast cotton/spandex stretch canvas - front, back upper hip and back inner thigh



CODE	COLOURS	SIZES
WBD1130	Navy, Black, Khaki, Stone, Charcoal	72 - 132 Active Fit



Flex & Move™ Stretch Trousers

- Contrast stretch cotton canvas fabrics with spandex
- Multi-purpose utility and cargo pocket options depending on style
- Two angled side pockets & two back pockets
- Hem boot cut-out with reinforced patch at back
- 7 reinforced belt loops
- YKK® zipper



WBT6130

WBTC6330

WBTC6331

CODE	DESCRIPTION	COLOURS	SIZES
WBT6130	Stretch Trouser	Navy, Black, Khaki, Stone, Charcoal	72 - 112R, 87 - 132S
WBTC6330	Stretch Utility Zip Cargo Trouser	Navy, Black, Stone, Charcoal	72 - 112R, 87 - 117S
WBTC6331	Stretch Utility Cargo Trouser	Navy, Black, Stone, Charcoal	72 - 112R, 87 - 117S

X Airflow™ Ripstop Range



X Airflow™ Ripstop Taped HI VIS Shirt

- 100% cotton Ripstop - 150gsm
- X Airflow ventilation at multiple heat stress areas - 100% cotton open mesh 125gsm
- Modern fit sizing
- 3M™ 8910P perforated reflective tape
- Two button adjustable sleeve cuff
- AS/NZS 4602.1:2011 Class D/N



CODE	COLOURS	SIZES
WBS6415T	Orange/Navy, Yellow/Navy, Yellow/Charcoal, Lime/Charcoal	S - 6XL



X Airflow™ Ripstop HI VIS Shirt

- 100% cotton Ripstop - 150gsm
- Modern fit sizing
- X Airflow ventilation at multiple heat stress areas - 100% cotton open mesh 125gsm
- Contoured shape two piece sleeve
- Two button adjustable sleeve cuff
- AS/NZS 4602.1:2011 Class D



CODE	COLOURS	SIZES
WBS6415	Orange/Navy, Yellow/Navy	S - 6XL



X Airflow™ Ripstop Taped HI VIS Shirt

- 100% cotton Ripstop - 150gsm
- Modern fit sizing
- X Airflow ventilation at multiple heat stress areas - 100% cotton open mesh 125gsm
- 3M™ 8910P perforated reflective tape
- Two button adjustable sleeve cuff
- AS/NZS 4602.1:2011 Class D/N



CODE	COLOURS	SIZES
WBS6416T	Orange	S - 6XL



X Airflow™ Ripstop Short Sleeve Shirt

- 100% cotton Ripstop - 150gsm
- Modern fit sizing
- Two button adjustable sleeve cuff
- Two chest pockets with touch tape closure
- X Airflow ventilation at multiple heat stress areas - 100% cotton open mesh 125gsm



CODE	COLOURS	SIZES
WBS1414	Black, Charcoal, Khaki, Navy	S - 6XL



X Airflow™ Ripstop Long Sleeve Shirt

- 100% cotton Ripstop - 150gsm
- Modern fit sizing
- Roll-up sleeve tab
- Two chest and sleeve patch pockets with touch tape closure
- X Airflow ventilation at multiple heat stress areas - 100% cotton open mesh 125gsm
- Two button adjustable sleeve cuff



CODE	COLOURS	SIZES
WBS6414	Black, Charcoal, Khaki, Navy	S - 6XL



X Airflow™ Ripstop Vented Work Short

- 100% cotton Ripstop - 240gsm
- Back yoke & gusset ventilation - 100% cotton open mesh 125gsm
- Curved waistband to prevent gaping at back
- Modern lower waist fit
- Multi-purpose pocket with flap on left hand side



CODE	COLOURS	SIZES
WBD1474	Khaki, Charcoal, Black, Navy	77 - 132



X Airflow™ Ripstop Vented Work Trousers

- 100% cotton twill Ripstop - 240gsm
- Back yoke and gusset ventilation - 100% cotton mesh
- Modern lower waist fit
- Curved waistband to prevent gaping at back
- Double layered knee patches with options to insert knee pads (not included)
- Taped option includes 3M™ 8910P (perforated) - AS/NZS 4602.1:2011 Class N



CODE	DESCR.	COLOURS	SIZES
WBT6474	Untaped	Black, Navy, Charcoal	77 - 112R, 87 - 132S
WBT6474T	Taped	Navy	



X Airflow™ Ripstop Engineered Cargo Work Trousers

- 100% cotton twill Ripstop - 240gsm
- Modern engineered fit with lower waist and contoured leg
- Curved waistband to prevent gaping at back
- Double layer contoured knee
- Hem boot cuff
- Taped option includes 3M™ 8910P (perforated) - AS/NZS 4602.1:2011 Class N



CODE	DESCR.	COLOURS	SIZES
WBTC6475	Untaped	Black, Khaki Navy, Charcoal	77 - 112R, 87 - 132S
WBTC6475T	Taped	Navy	

Night Safety Range



Bisley

Taped Night Shirt

- 100% cotton preshrunk drill - 190gsm
- 3M™ 8910 biomotion taping
- AS/NZS 4602.1:2011 Class N



CODE	COLOURS	SIZES
WBS6807T	White	S - 6XL

Bisley

Taped ¼ Zip Night Pullover

- 65% polyester/ 35% cotton fleece - 300gsm
- 3M™ 8910 biomotion taping
- Elasticised rib knit hem and cuff
- AS/NZS 4602.1:2011 Class N



CODE	COLOURS	SIZES
WBP6321XT	White	XS - 6XL

Bisley



Taped Night Drill Trouser

- 100% cotton preshrunk drill - 310gsm
- 3M™ 8910 biomotion taping
- Improved fit with internal reinforced front rise
- AS/NZS 4602.1:2011 Class N

CODE	COL.	SIZES
WBT6808T	White	77 - 112R, 87 - 132S

Bisley



Taped Night Drill Overall

- 100% cotton preshrunk drill - 310gsm
- 3M™ 8910 biomotion taping on sleeves/legs
- Double layered knee
- AS/NZS 4602.1:2011 Class N

CODE	COL.	SIZES
WBO6806T	White	77 - 117R, 92 - 132S

Painter's Whites Range



Bisley

Painters Contrast Polo Shirt

- 100% polyester mesh - 130gsm
- Lightweight, breathable and quick dry mesh fabric
- Contrast side panels, knit rib collar and sleeve stripes



CODE	COLOURS	SIZES
WBP1423	White	XS - 6XL

Bisley

Painters Contrast Cargo Short

- 97% cotton/3% spandex - 280gsm
- Stretch cotton canvas
- Contrast grey oxford highlights
- Multifunctional cargo pockets



CODE	COLOURS	SIZES
WBDC1422	White	72 - 132

Bisley



Painters Contrast Cargo Trouser

- 97% cotton/3% spandex - 280gsm
- Stretch cotton canvas
- Contrast grey oxford highlights
- Multifunctional cargo pockets
- Double layer shaped knee

CODE	COL.	SIZES
WBTC6422	White	72 - 112R, 87 - 132S

Bisley



Painters Contrast Bib & Brace Overall

- 97% cotton/3% spandex - 280gsm
- Stretch cotton canvas - elastic back
- Contrast grey oxford highlights
- Multifunctional pockets
- Double layer shaped knee

CODE	COL.	SIZES
WBO0422	White	72 - 117R, 92 - 132S

Women's Workwear Range



Cool Lightweight Taped HI VIS Shirt

- 100% cotton preshrunk drill - 155gsm
- Panelled front with bust and waist shaping
- Two button down chest pockets
- Underarm/back mesh ventilation
- 3M™ 8910 tape
- AS/NZS 4602.1:2011 Class D/N



MATERNITY STYLE AVAILABLE

*Refer to inside back cover for details

CODE	COLOURS	SIZES
WBSL6896T	Yellow/Navy, Orange/Navy	8 - 24
WBSL6896TP	Pink/Navy - NBCF Logo*	8 - 24
WBSL6696T	Yellow/Pink, Orange/Pink - NBCF Logo*	8 - 24



Regular Weight Taped HI VIS Shirt

- 100% cotton preshrunk drill - 190gsm
- Panelled front with bust and waist shaping
- Two button down chest pockets
- Underarm/back mesh ventilation
- 3M™ 8910 tape
- AS/NZS 4602.1:2011 Class D/N



CODE	COLOURS	SIZES
WBSL6456T	Yellow/Navy, Orange/Navy	8 - 24



X Airflow™ Ripstop Taped HI VIS Shirt

- 100% cotton Ripstop - 150gsm
- Cotton mesh Bisley X Airflow™ ventilation at multiple heat stress areas
- Perforated 3M™ 8910P reflective tape
- Twin chest patch pockets with touch tape closure
- AS/NZS 4602.1:2011 Class D/N



CODE	COLOURS	SIZES
WBSL6415T	Yellow/Navy, Orange/Navy	8 - 24



Regular Weight HI VIS Shirt

- 100% cotton preshrunk drill - 190gsm
- Panelled front with bust and waist shaping
- Two button down chest pockets
- Two button adjustable sleeve cuff
- AS/NZS 4602.1:2011 Class D



CODE	COLOURS	SIZES
WBSL6267	Yellow/Navy, Orange/Navy	8 - 24



Regular Weight Shirt

- 100% cotton preshrunk drill - 190gsm
- Panelled front with bust and waist shaping
- Two button down chest pockets
- Two button adjustable sleeve cuff



CODE	COLOURS	SIZES
WBSL6339	Navy	8 - 24



Cool Vented Lightweight Trousers

- 100% cotton preshrunk drill - 190gsm
- Back yoke with open mesh vents
- Two angled side pockets
- Two welt pockets with touch tape closure
- Back patch pocket
- 3M™ 8910 tape option - AS/NZS 4602.1:2011 Class N



CODE	DESCR.	COLOURS	SIZES
WBTL6431	Untaped	Navy	6 - 24
WBTL6431T	Taped	Navy	



Original Cotton Drill Trousers

- 100% cotton preshrunk drill - 310gsm
- Two angled side pockets
- Two welt pockets with touch tape closure
- Mobile phone pocket on RHS
- YKK® zipper
- 3M™ 8910 tape option - AS/NZS 4602.1:2011 Class N



MATERNITY STYLE AVAILABLE

CODE	DESCR.	COLOURS	SIZES
WBTL6007	Untaped	Navy	6 - 24
WBTL6007T	Taped	Navy	



Cool Lightweight Utility Shorts

- 100% cotton preshrunk drill - 240gsm
- Two angled side pockets
- Utility pocket with touch tape on right hand side
- Cargo pocket with touch tape on left hand side
- YKK® zipper



CODE	COLOURS	SIZES
WBDL1999	Navy, Khaki	6 - 24

Heavy Duty Winter Waterproof Jackets & Combos



Bisley
WORKWEAR

Taped HI VIS 5-in-1 Jacket

- Combination jacket & vest
- 5 wear options

Jacket:

- 100% polyester Oxford with PU coating - 300D
- Waterproof and breathable fabric
- Fully seam sealed
- Mesh lined

Vest:

- Zip out reversible padded body warmer with detachable zip-out sleeves
- 100% polyester fleece lining
- Heavy duty two-way zippered front opening
- AS/NZS 4602.1:2011 Class D/N



CODE	DESCRIPTION	COLOURS	SIZES
WBJ6975	5-in-1 Jacket/Vest	Yellow/Navy, Orange/Navy	XS - 6XL
CRT6965T	Rain Trousers	Orange/Navy	XS - 6XL



Max Cross Back 4-in-1 HI VIS Jacket & Vest

- Waterproof polyester Oxford PU coated - 150D
- Polyester mesh lined jacket
- Detachable hood
- Zip-out reversible vest
- 130gsm polar fleece lined vest
- X back HI VIS jacket and vest tape
- AS/NZS 4602.1:2011 Class D/N



CODE	DESCRIPTION	COLOURS	SIZES
WMJ331	Jacket/Vest	Orange	S - 5XL
WMV214X	Vest	Orange	S - 5XL



Eyre Two Tone 4-in-1 HI VIS Jacket

- Waterproof polyester Oxford PU coated - 150D
- Polyester mesh lined jacket
- Two-way zip closure
- Detachable hood
- Zip-out reversible vest
- 130gm polar fleece lined vest
- H back HI VIS tape
- AS/NZS 4602.1:2011 Class D/N



CODE	DESCRIPTION	COLOURS	SIZES
WMJ881	4-in-1 Jacket/Vest	Yellow/Navy, Orange/Navy, Yellow/Green	XS - 5XL, 7XL, 9XL, S - 5XL
WMV214	Vest	Yellow, Orange	XS - 5XL, 7XL, 9XL
CRT200	D/N Cargo Trousers	Yellow/Navy, Orange/Navy	S/M, L/XL, 2XL/3XL, 4XL/5XL



Tempest Two Tone 4-in-1 HI VIS Jacket

- Waterproof polyester Oxford PU coated - 300D
- Polyester mesh lined jacket
- Seam sealed
- Two-way zip closure
- Concealed hood
- Zip-out reversible vest
- Vest 280gsm polar fleece
- H back HI VIS tape
- AS/NZS 4602.1:2011 Class D/N
- AS/NZS 1906.4:2010



CODE	DESCRIPTION	COLOURS	SIZES
WMJ5255	4-in-1 Jacket/Vest	Yellow/Navy, Orange/Navy	S - 5XL
WMV5233	Vest	Yellow, Orange	S - 5XL



Platinum FR/Anti-Static HI VIS Jacket

- 98% polyester Oxford, 2% carbon
- Waterproof breathable, PU coated - 300D
- Concealed hood
- 100% cotton lined
- Flame retardant/Anti-static to EN11612 indices 1/5X40 and EN1149:3:2004
- Flame retardant H back HI VIS tape - 3M™ 8935
- Separate vest also available
- AS/NZS 4602.1:2011 Class D/N
- AS/NZS 1906.4:2010



CODE	DESCR.	COLOURS	SIZES
WMJ5140	FR Jacket	Yellow/Navy, Orange/Navy	S - 5XL
WMV5150	FR Vest	Orange/Navy	S - 5XL



Bizflame FR/Anti-Static Multi Lite HI VIS Jacket

- Waterproof breathable polyester Oxford PU coated with 2% carbon
- Bizflame outer fabric - 250g
- 100% cotton flame resistant lining
- Flame retardant/Anti-static to EN ISO 14116 Index 3 /12H/40 and EN1149-5
- Taped seams, packaway hood
- Flame resistant H back HI VIS tape
- Biomotion tape pattern
- Separate FR trousers also available



CODE	DESCR.	COLOURS	SIZES
WMJ774	FR Jacket	Yellow, Orange	S - 3XL
CRT780	FR Trousers	Orange, Yellow	S - 2XL, S - 4XL



Flex & Move™ Heavy Duty Dobby Jacket

- 100% polyester doobby with TPU membrane laminated - 255gsm
- Fully seam sealed waterproof garment
- Waterproof rating: Up to 15,000mm H₂O
- Dual layer fabric with internal 160gsm polyester wadding for warmth
- Multi-functional waterproof zip pockets
- Shaped built in hood with collar stand for protection c/w adjustable cord
- Elasticated sleeve cuff adjuster



CODE	COLOURS	SIZES
WBJ6943	Black	XS - 6XL

General Winter Waterproof Jackets



Bisley
WORKWEAR

Taped HI VIS Two Tone Puffer Jackets & Vests

- 100% polyester Mini Ripstop TPU coated - 150D
- Two layer showerproof fabric
- Polyester lining with quilted wadding
- Adjustable quilt lined hood
- H or X pattern tape options with biomotion taping on sleeves
- Waterproof zippers
- HI VIS puffer vest options
- AS/NZS 4602.1:2011 Class D/N



CODE	DESCRIPTION	COLOURS	SIZES
WBJ6929HT	Jacket H-Back	Yellow/Navy, Orange/Navy	XS - 6XL
WBJ6379XT	Jacket X-Back	Orange	XS - 6XL
WBV0329HT	Vest H-Back	Yellow	XS - 6XL
WBV0379XT	Vest X-Back	Orange	XS - 6XL



208 Taped HI VIS Two Tone Fleece Lined Jacket

- 100% polyester Oxford - 300D
- Waterproof fabric with taped seams
- Polyester fleece lining
- Pack away detachable hood
- H pattern tape
- Two-way zip with press stud flap
- AS/NZS 4602.1:2011 Class D/N



CODE	COLOURS	SIZES
WMJ208	Yellow/Navy, Orange/Navy	S - 5XL

Bisley
WORKWEAR

HI VIS Ripstop Bonded Fleece Jacket

- 100% polyester bonded Ripstop TPU and polyester polar fleece
- Two layer showerproof fabric
- 3M reflective heat sealed segmented taped hoop pattern
- Biomotion taping on sleeves
- Built-in adjustable hood
- Two waist pockets with zip closure
- AS/NZS 4602.1:2011 Class D/N



CODE	COLOURS	SIZES
WBJ6934T	Yellow/Navy, Orange/Navy	XS - 6XL



HI VIS Padded Traffic Jacket

- 100% polyester Oxford PU coated - 300D
- Pack away hood
- Polyester lined and padded
- Waterproof taped seams and stain resistant finish
- Biomotion taped sleeves with inner cuffs
- Two-way zip closure and 4 pockets
- AS/NZS 4602.1:2011 Class D/N



CODE	DESCR.	COL.	SIZES
WMJ460H	H Back Jacket	Yellow	XS - 6XL
		Orange	S - 5XL
WMJ460X	X Back Jacket	Orange	S - 5XL



Logic 20/20 HI VIS Taped Jacket

- Polyester 300D Ripstop PU coated
- High collar design with micro fleece
- Waterproof seam sealed construction
- Polyester lined and quilted
- Two-way zip closure and full length storm flap
- AS/NZS 4602.1:2011 Class D/N
- AS/NZS 1906.4:2010



CODE	COLOURS	SIZES
WMJ3280	Yellow/Navy, Orange/Navy	S - 5XL



204 HI VIS Lined Flying Jacket

- Polyester Oxford PU coated - 300D
- Waterproof - tape seam construction
- Polyester lined and quilted
- Two-way zip & pack away hood
- AS/NZS 4602.1:2011 Class D/N

CODE	COLOURS	SIZES
WMJ204	Yellow/Navy, Orange/Navy	S - 5XL



304 HI VIS Lined Bomber Jacket

- Polyester Oxford PU coated - 150D
- Waterproof - tape seam construction
- Polyester lined and quilted
- Two-way zip & pack away hood
- AS/NZS 4602.1:2011 Class D

CODE	COLOURS	SIZES
WMJ304	Yellow/Navy, Orange/Navy	S - 5XL



504 Taped HI VIS Lined Bomber Jacket

- Polyester Oxford PU coated - 150D
- Waterproof - tape seam construction
- Polyester lined and quilted
- Two-way zip & pack away hood
- AS/NZS 4602.1:2011 Class D/N

CODE	COLOURS	SIZES
WMJ504	Yellow/Navy, Orange/Navy	S - 5XL

Unlined Water-proof Jackets & Raincoats



Eyre 306 Two Tone HI VIS Jacket

- Polyester Oxford PU coated - 150D
- Polyester mesh lined
- Waterproof - taped seams
- Pack away detachable hood
- Two-way zip
- HI VIS pull-on cargo pocket
- Trousers with boot snaps sold separately
- AS/NZS 4602.1:2011 Class D/N



CODE	DESCRIPTION	COLOURS	SIZES
CRJHV306	HI VIS D/N Jacket	Yellow/Navy, Orange/Navy	XS - 5XL, 7XL, 9XL
CRT200	HI VIS D/N Cargo Trousers	Navy	S/M, L/XL, 2XL/3XL, 4XL/5XL



Kimberley 206 Two Tone HI VIS Jacket

- Polyester Oxford PU coated - 150D
- Polyester mesh lined
- Waterproof - taped seams
- Pack away detachable hood
- Two-way zip
- HI VIS pull-on cargo pocket
- Trousers with boot snaps sold separately
- AS/NZS 4602.1:2011 Class D



CODE	DESCRIPTION	COLOURS	SIZES
CRJHV206	HI VIS D/N Jacket	Yellow/Navy, Orange/Navy	S - 5XL
CRT202	HI VIS D/N Trousers	Navy	S/M, L/XL, 2XL/3XL, 4XL/5XL



HI VIS Stretch PU Jacket

- 2 layer water-proof fabric
- PU coated - 190gsm
- Stretch PU for comfort
- H pattern tape with biomotion taping on sleeve
- Built-in concealed hood
- Heat sealed seams
- Pull-on trouser with double layer knee sold separately
- AS/NZS 4602.1:2011 Class D/N



CODE	DESCR.	COLOURS	SIZES
CRJ6935T	Taped Jacket	Yellow/Navy, Orange/Navy	XS - 6XL
CRT6936T	Taped Trousers	Navy	XS - 6XL



Flex & Move™ Shield Jacket

- 100% polyester with TPU membrane fleece laminate bonded with fleece
- Showerproof
- Silver infrared thermal lined mesh body for warmth and taffeta lined sleeves
- Waterproof zip pockets including two hand-warmer pockets
- Shaped built-in hood with collar stand with adjustable toggle
- Contrast abrasion resistance panels



CODE	COLOURS	SIZES
WBJ6937	Charcoal	XS - 6XL



HI VIS X Back Stretch Jacket

- 2 layer water-proof fabric
- 100% PU coated - 190gsm
- Stretch PU for comfort
- X back pattern reflective tape with biomotion taping on sleeve
- Built-in concealed hood
- Sealed seams & internal neoprene storm cuff
- AS/NZS 4602.1:2011 Class D/N



CODE	COLOURS	SIZES
CRJ6955XT	Orange	XS - 6XL



Industrial Waterproof PVC Clothing

- PVC/polyester fabrics
- Jackets have elastic cuffs, zip & stud front closure, two pockets and hood with draw strings
- Trousers have elastic waist and cuffs, pocket slots
- No standards approvals



CODE	DESCRIPTION	COLOURS	SIZES
CRS7815	Jacket/Trouser Set	Yellow, Orange	S - 5XL
CRJ7510	Yellow PVC Jacket	Yellow	S - 4XL
CRT7511	Yellow PVC Trousers	Yellow	S - 4XL



Mini Ripstop Jacket

- 3 layer waterproof breathable fabric
- Sealed seams
- 100% polyester Mini Ripstop TPU coated - 166gsm
- Built-in concealed hood
- Shaped back tail and sleeve hem opening
- Waist pockets with zipper closure



CODE	COLOURS	SIZES
CRJ6926	Black	XS - 6XL



Carey 206 Jacket and 205 Trousers

- 100% polyester Oxford - 200D
- Polyester mesh lined
- Pack away detachable hood
- Waterproof - taped seams
- Combination zip and stud front opening
- Pull-on trousers with side zip leg opening sold separately



CODE	DESCR.	COLOURS	SIZES
CRJ206	Rain Jacket	Green	XXS - 5XL
		Navy	XXS - 7XL, 9XL
		Black	XXS - 5XL, 7XL, 9XL
CRT205	Rain Trousers	Green, Navy, Black	XXS/XS - 8XL/9XL

Cotton Drill Jackets



3-in-1 HI VIS Drill Jacket & Vest Combo

- Cotton preshrunk drill - 310gsm
- Cotton quilted lining with insulated polyester wadding
- Reflective 3M™ tape in 'H' pattern around body
- Detachable taped HI VIS vest
- Angled side seam pockets (jacket & vest)
- AS/NZS 4602.1:2011 Class D/N



CODE	COLOURS	SIZES
WBJ6970T	Yellow/Navy, Orange/Navy	XS - 5XL



Hume HI VIS 4-in-1 Drill Jacket & Vest Combo

- Mid length jacket with cotton lining
- 100% cotton drill
- UPF50+ sun protection
- Reversible vest with cotton lining
- Day/night jacket and vest can be worn together or separately
- AS/NZS 4602.1:2011 Class D/N



CODE	COLOURS	SIZES
WMJ777	Yellow/Navy, Orange/Navy	XS - 5XL



Taped HI VIS Drill Jacket

- 100% cotton preshrunk drill - 310gsm
- Cotton quilted lining with polyester wadding
- H pattern reflective taping
- YKK® zipper with plastic slider
- Internal phone pocket
- AS/NZS 4602.1:2011 Class D/N



CODE	COLOURS	SIZES
WBJ6710T	Yellow/Navy, Orange/Navy, Yellow/Green	XS - 6XL



Taped HI VIS Drill Jacket - Liquid Repellent Finish

- 100% cotton drill
- Liquid repellent 240gsm fabric
- Cotton flannelette lining - 170gsm
- Hoop pattern reflective tape
- AS/NZS 4602.1:2011 Class D/N



CODE	COLOURS	SIZES
WBJ6917T	Yellow/Navy, Orange/Navy	XS - 6XL



HI VIS Quilt Lined Drill Jacket

- Cotton drill outer - 311gsm
- Quilt padded lining
- UPF50+
- Front zip opening
- 3M™ reflective tape
- AS/NZS 4602.1:2011 Class D/N



CODE	COLOURS	SIZES
WMJ987	Yellow/Navy, Orange/Navy	XS - 5XL



HI VIS Drill Jacket - Liquid Repellent Finish

- 100% cotton drill - 240gsm
- Liquid repellent finish
- Cotton flannelette lining
- Internal cotton rib cuffs
- YKK® zipper with plastic slider
- Internal phone pocket
- AS/NZS 4602.1:2011 Class D



CODE	COLOURS	SIZES
WBJ6917	Yellow/Navy, Orange/Navy	XS - 6XL



Drill Jacket - Liquid Repellent Finish

- 100% cotton drill - 240gsm
- Liquid repellent finish
- Two angled side welt pockets
- Cotton flannelette lining
- Internal cotton rib cuffs
- YKK® zipper with plastic slider
- Internal phone pocket



CODE	COLOURS	SIZES
WBJ6916	Black, Navy	XS - 6XL



HI VIS Quilt Padded Drill Vest

- 100% cotton drill - 310gsm
- Cotton lined for added warmth
- Fully reversible for multi use
- H pattern reflective tape
- Four pockets
- Combination zip
- AS/NZS 4602.1: 2011 Class D/N



CODE	COLOURS	SIZES
WMV278	Yellow, Orange	XS - 5XL

Soft Shell Jackets/Hoodies



Bisley
WORKWEAR

Taped HI VIS Soft Shell Jacket

- 100% polyester mechanical stretch twill with bonded fleece and TPU lamination - 310gsm
- Showerproof fabric with breathable membrane
- Hoop pattern reflective tape
- Eyelet ventilation
- Sleeve cuff adjusters
- Zippered waist pockets
- AS/NZS 4602.1:2011 Class D/N



CODE	COLOURS	SIZES
WBJ6059T	Yellow/Navy, Orange/Navy	XS - 6XL

Bisley
WORKWEAR

Taped HI VIS Soft Shell Vest

- 100% polyester mechanical stretch twill with bonded fleece and TPU lamination - 310gsm
- Showerproof fabric with breathable membrane
- Hoop pattern and over the shoulder reflective tape
- Zippered waist pockets
- Elasticated drawcord at hem
- AS/NZS 4602.1:2011 Class D/N



CODE	COLOURS	SIZES
WBV0348T	Yellow/Navy, Orange/Navy	XS - 6XL

Brahma
The name to trust

HI VIS Soft Shell Hoodie Jacket

- Breathable polyester soft shell - 94% polyester/6% spandex
- Brushed fleece lining
- Hoop pattern reflective tape
- Water resistant fabric up to 8000mm, with breathable membrane
- Integrated hoodie style design jacket with draw cord toggles
- Internal full length storm flap
- AS/NZS 4602.1:2011 Class D/N



CODE	COLOURS	SIZES
WMJ3000	Yellow/Navy, Orange/Navy	S - 5XL

Brahma
The name to trust

Cradle Mountain HI VIS Soft Shell Jacket

- Breathable polyester soft shell - 94% polyester/6% spandex
- Polyester quilt lined
- Zip-off hood
- H pattern reflective tape
- Draw cord and toggle waist
- Water resistant fabric up to 8000mm, with breathable membrane
- AS/NZS 4602.1:2011 Class D/N
- AS/NZS 1906.4:2010



CODE	COLOURS	SIZES
WMJ30670	Yellow/Navy, Orange/Navy	S - 5XL

Bisley
WORKWEAR

Soft Shell Jacket

- Showerproof fabric with breathable membrane
- Full zip
- 96% polyester/4% spandex with bonded fleece and TPU lamination - 310gsm
- Eyelet ventilation under arms
- Bonded internal fleece face
- Elasticated drawcord at hem
- Sleeve cuff adjusters



CODE	COLOURS	SIZES
WBJ6060	Black, Navy, Charcoal	XS - 6XL

Brahma
The name to trust

Cradle Mountain Soft Shell Jacket

- Breathable polyester soft shell - 94% polyester/6% spandex
- Polyester quilt lined
- Zip-off hood
- Draw cord and toggle waist
- Water resistant fabric up to 8000mm, with breathable membrane
- Sleeve cuff adjusters



CODE	COLOURS	SIZES
WMJ3060	Black	S - 5XL

HUSKI
WORKWEAR

Chassis 2-in-1 HI VIS Soft Shell Jacket

- Polyester soft shell - 300gsm and polyester lined
- Breathable, windproof and water resistant
- Zip-out sleeves for multi use
- Card holder for ID card display
- Hoop pattern and shoulder reflective tape
- Four pockets for storage
- AS/NZS 4602.1:2011 Class D/N



CODE	COLOURS	SIZES
WMJ8074	Yellow/Navy, Orange/Navy	S - 5XL

Bisley
WORKWEAR

Soft Shell Vest

- 96% polyester/4% spandex with bonded fleece and TPU lamination - 310gsm
- Showerproof fabric with breathable membrane
- Bonded internal fleece face
- Full zip front with chin guard zip stopper
- Elasticated drawcord at hem



CODE	COLOURS	SIZES
WBV0360	Black	XS - 6XL

Fleece Jackets, Pullovers, Hoodies



HI VIS Polar Fleece Pullover

- 100% polyester - 285gsm
- Anti-pill durable fleece fabric
- Contrast two tone panels
- ¼ zip front
- Drawcord adjustable hem
- Side zip pockets
- AS/NZS 4602.1:2011 Class D or D/N with tape



CODE	DESCR.	COLOURS	SIZES
WJP115	Untaped	Yellow/Navy	S - 5XL, 8XL
		Orange/Navy, Yellow/Green	S - 5XL
WJP215	Taped	Yellow/Navy, Orange/Navy, Yellow/Green	S - 5XL



HI VIS Polar Fleece Hoodie Jacket

- 100% polyester - 300gsm
- Premium low pill fleece
- Full open zip
- Elasticated rib knit hem
- Front contrast kangaroo style shaped pockets
- Shaped hood with contrast lining
- AS/NZS 4602.1:2011 Class D or D/N with tape



CODE	DESCR.	COLOURS	SIZES
WBJ6819	Untaped	Yellow/Navy, Orange/Navy	XS - 6XL
WBJ6819T	Taped	Yellow/Navy, Orange/Navy	XS - 6XL



HI VIS Fleece ¼ Zip Pullover

- 100% polyester - 300gsm
- Premium polyester low pill fleece
- ¼ zip collar
- Rib cuffs with thumb opening
- Elasticated rib knit hem
- AS/NZS 4602.1:2011 Class D or D/N with tape



CODE	DESCRIPTION	COLOURS	SIZES
WBP6989	Untaped	Yellow/Navy, Orange/Navy	XS - 6XL
WBP6989T	Taped	Yellow/Navy, Orange/Navy	XS - 6XL



HI VIS Fleece Hoodie Pullover

- 100% polyester - 300gsm
- Premium polyester low pill fleece
- Front contrast kangaroo style shaped pockets
- Internal rib collar
- Shaped hood with contrast lining
- Elasticated rib knit hem
- AS/NZS 4602.1:2011 Class D or D/N with tape



CODE	DESCRIPTION	COLOURS	SIZES
WBP6619	Untaped	Yellow/Navy, Orange/Navy	XS - 6XL
WBP6619T	Taped	Yellow/Navy, Orange/Navy	XS - 6XL



HI VIS Fleece Water Repellent Jacket

- 100% polyester - 320gsm
- Premium water resistant fabric
- Anti-pill durable fleece fabric
- Contrast two-tone panels
- Full zip front
- Drawcord adjustable hem
- AS/NZS 4602.1:2011 Class D



CODE	DESCRIPTION	COLOURS	SIZES
WJP315	Full Zip HI VIS Fleecy Jacket	Yellow/Navy, Orange/Navy	S - 5XL



HI VIS Fleece Water Repellent Hooded Jacket

- 100% polyester - 320gsm
- Hoodie style for added protection
- Premium water resistant fabric
- Anti-pill durable fleece fabric
- Contrast two-tone panels
- Full zip front
- Drawcord adjustable hem
- AS/NZS 4602.1:2011 Class D



CODE	DESCRIPTION	COLOURS	SIZES
WJP317	Full Zip HI VIS Fleecy Hoodie	Yellow/Navy, Orange/Navy	S - 5XL

Polo Shirts



Fitzroy HI VIS Micro Mesh Polos - Short Sleeve

- 100% polyester micro mesh - 134gsm
- Quality wicking fabric enhances drying and aids stain removal
- Breathable fabric to draw moisture away
- Cool, dry and comfortable wearing
- Contrast two-tone panels
- Chest pocket
- AS/NZS 4602.1:2011 Class D or D/N with tape



CODE	DESCR.	COLOURS	SIZES
WP110	Untaped	Yellow/Navy, Orange/Navy	S - 5XL, 7XL, 9XL
		Yellow/Green	S - 5XL
WP510	Taped	Yellow/Navy, Orange/Navy, Yellow/Green	S - 5XL



Fitzroy HI VIS Micro Mesh Polos - Long Sleeve

- 100% polyester micro mesh - 134gsm
- Quality wicking fabric enhances drying and aids stain removal
- Breathable fabric to draw moisture away
- Cool, dry and comfortable wearing
- Contrast two-tone panels
- Chest pocket
- AS/NZS 4602.1:2011 Class D or D/N with tape



CODE	DESCR.	COLOURS	SIZES
WP113	Untaped	Yellow/Navy, Orange/Navy	S - 5XL, 7XL, 9XL
		Yellow/Green	S - 5XL
WP513	Taped	Yellow/Navy, Orange/Navy, Yellow/Green	S - 5XL

Bisley

HI VIS Mesh Polos - Short Sleeve

- 100% polyester mesh - 130gsm
- Exceptional elasticity, soft and breathable mesh fabric
- Contrast coloured rib collar and cuff with double HI VIS piping
- Hoop pattern tape option
- Contrast underarm extended gusset
- Spliced front, full HI VIS back
- AS/NZS 4602.1:2011 Class D or D/N with perforated tape



CODE	DESCRIPTION	COLOURS	SIZES
WBP1219	Untaped	Yellow/Navy, Orange/Navy	XS - 6XL
WBP1219T	Taped	Yellow/Navy, Orange/Navy	XS - 6XL

Bisley

HI VIS Mesh Polos - Long Sleeve

- 100% polyester mesh - 130gsm
- Exceptional elasticity, soft and breathable mesh fabric
- Contrast coloured rib collar and cuff with double HI VIS piping
- Hoop pattern tape option
- Contrast underarm extended gusset
- Spliced front, full HI VIS back
- AS/NZS 4602.1:2011 Class D or D/N with perforated tape



CODE	DESCRIPTION	COLOURS	SIZES
WBP6219	Untaped	Yellow/Navy, Orange/Navy	XS - 6XL
WBP6219T	Taped	Yellow/Navy, Orange/Navy	XS - 6XL

WORKKIT

HI VIS Cotton Back Mesh Polo - Long Sleeve

- Rib sleeve cuff
- Left chest pocket
- 80% polyester/ 20% cotton back knit - 180gsm
- Underarm mesh vent
- AS/NZS 4602.1:2011 Class D



CODE	DESCR.	COLOURS	SIZES
WP5004	Untaped	Yellow/Navy, Orange/Navy	XS - 6XL

WORKKIT

HI VIS Taped Cotton Back Mesh Polo - Long Sleeve

- Rib sleeve cuff
- Left chest pocket
- 80% polyester/ 20% cotton back knit - 180gsm
- Underarm mesh vent
- Reflective tape - hoop pattern
- AS/NZS 4602.1:2011 Class D/N



CODE	DESCR.	COLOURS	SIZES
WP5004T	Taped	Yellow/Navy, Orange/Navy	XS - 6XL

WORKKIT

HI VIS Cotton Back Mesh Polo - Short Sleeve

- Left chest pocket
- 80% polyester/ 20% cotton back knit - 180gsm
- Underarm mesh vent
- AS/NZS 4602.1:2011 Class D



CODE	DESCR.	COLOURS	SIZES
WP5005	Untaped	Yellow/Navy, Orange/Navy	XS - 6XL

PROTECTIVE CLOTHING

APPLICATION

When engineering and administrative control measures are unable to reduce exposure to hazards that may impact any part of the body, employees should be supplied with, trained in the use of, and wear effective workwear and protective clothing.

RISK ASSESSMENT

The process of carrying out a risk assessment should include a site survey that identifies workplace activities, lists the hazards present and assesses the level of risk that needs to be covered through the provision of protective clothing.







Determining the level of protection required should include which parts of the body require protection, the type of protection and with reference to appropriate standards should they exist.

Research should be carried out to identify products that provide the required level of protection and should be supported with appropriate documentation and product labelling. Specific attention should be given to the functionality of garments that are multi-layered or are worn in conjunction with other types of PPE.

Wearer trials are an important part of the evaluation process and obtaining wearer feedback is critical to ensure product suitability. Issues relating to sizing, ease of maintenance and durability are important factors.

CHEMICAL & PARTICULATE PROTECTIVE CLOTHING

AS/NZS 4501.2 (EN ISO 13688) outlines general design considerations and specifies pictogram markings as per ISO 7000. Protective Clothing standards of relevance are:

SYMBOL	EN TYPE	TYPE DESCRIPTION
	Type 1 EN 943-1 EN 943-2	Gas Tight Protective Clothing Protective clothing against liquid & gaseous chemicals, aerosols and solid particulates.
	Type 2 EN 943-1	Non Gas Tight Protective Clothing Suits which retain positive pressure to prevent ingress of dusts, liquids & vapours.
	Type 3 EN 14605/(EN ISO17491-3)	Liquid Jet Protective Clothing Suits which can protect against strong and directional jets of liquid chemicals.
	Type 4 EN 14605/(EN ISO17491-4)	Liquid Spray Protective Clothing Suits which offer protection against saturation of liquid chemicals.
	Type 5 EN ISO 13982-1	Particle Protective Clothing Suits which provide protection to the full body against airborne and solid particulates.
	Type 6 EN 13034/(EN ISO17491-4)	Limited Liquid Splash Protective Clothing Suits which offer limited protection against a light spray of liquid chemicals.

SAFETY TIPS

- Include hands and feet in all protective clothing considerations.
- Ensure chemical protective clothing is matched to the specific chemicals in use.
- Ensure workers are aware of the capabilities and limitations of selected protective clothing.
- Critical protective clothing should be regularly checked for serviceability.
- Procedures covering the handling of contaminated clothing should be established eg. toxic chemicals & dusts.

All workers should be trained in the correct use and maintenance of personal protective apparel.

FLAME RETARDANT WORKWEAR

NFPA 70E 2015 is an international standard for 'Electrical Safety Requirements for Employee Workplaces'. NFPA 70E requires workers to wear flame resistant protective clothing wherever there is a possible exposure to electric arc flash.

Personal Protective Equipment (PPE) Ratings:

PPE Category	PPE (ATV Rating) Table 130.7 (C) (16)
1	Arc-Rated Clothing, Minimum ATPV of 4 cal/cm ²
2	Arc-Rated Clothing, Minimum ATPV of 8 cal/cm ²
3	Arc-Rated Clothing Selected so that the system Arc Rating Meets the Required Minimum ATPV of 25 cal/cm ²
4	Arc-Rated Clothing Selected so that the system Arc Rating Meets the Required Minimum ATPV of 40 cal/cm ²

USEFUL REFERENCES

AS/NZS 4501 Set:2008 Occupational Protective Clothing Set.
AS/NZS 4836:2011 Safe working on or near low-voltage electrical installations and equipment, and the US NFPA 70E Standard.

FLAME RESISTANT CLOTHING	56
VESTS	58
FORESTRY	59
DISPOSABLE CLOTHING	60
FREEZER/COOLING	63
WELDING	64
MISCELLANEOUS	65
BAGS & BACKPACKS	66

Bisley TenCate Tecasafe® Inherently Flame Resistant Clothing



Bisley

TenCate Tecasafe® Plus 700 HI VIS FR Vented Shirt

- Tecasafe® Plus 700 FR Modacrylic, Lyocell, Aramid - 238gsm
- Sto-nor 9801 FR reflective tape
- Action back panel ventilation with two openings and underarm ventilation - TenCate FR Mesh - 152gsm
- HI VIS D/N - AS/NZS 4602.1:2011
- ATPV 8 - 9 cal/cm², PPE2



CODE	DESCRIPTION	COLOURS	SIZES
WBS8081T	Mens	Orange	XS - 6XL
WBS8082T	Mens Two Tone	Yellow/Navy, Orange/Navy	XS - 6XL
WBSL8082T	Womens Two Tone	Orange/Navy	8 - 24

Bisley

TenCate Tecasafe® Plus 580 HI VIS Lightweight FR Vented Shirt

- Tecasafe® Plus 580 FR Modacrylic, Lyocell, Aramid - 197gsm
- Sto-nor 9801 FR reflective tape
- Action back panel ventilation with two openings and underarm ventilation - TenCate FR Mesh - 152gsm
- HI VIS D/N - AS/NZS 4602.1:2011
- ATPV 6 - 7 cal/cm², PPE1



CODE	DESCRIPTION	COLOURS	SIZES
WBS8097T	Mens	Orange	S - 6XL
WBS8098T	Mens Two Tone	Yellow/Navy, Orange/Navy	S - 6XL
WBSL8098T	Womens Two Tone	Orange/Navy	8 - 24

Bisley

TenCate Tecasafe® HI VIS FR Engineered Coveralls

- Tecasafe® Plus 700 regular weight or Tecasafe® Plus 580 lightweight options
- Sto-nor 9801 FR reflective tape
- Action back panel ventilation with two openings and underarm ventilation - TenCate FR Mesh - 152gsm
- 10 multifunctional pockets
- Concealed press snap front closure
- HI VIS D/N - AS/NZS 4602.1:2011



WBO8185T



WBO8186T



WBO8086T

CODE	DESCRIPTION	COLOURS	SIZES
WBO8185T	Lightweight Non Vented ATPV 6 - 7 cal/cm ² , PPE1	Orange	77 - 117R, 92 - 132S
WBO8186T	Lightweight Vented ATPV 6 - 7 cal/cm ² , PPE1	Orange/Navy	
WBO8086T	Regular Weight Vented ATPV 8 - 9 cal/cm ² , PPE2	Yellow/Navy, Orange/Navy	

Bisley

HI VIS FR Wet Weather Jacket

- Three layer fabric
- Outer: 98% polyester/2% anti static carbon yarn
- Mid: PU coating
- Inner: 60% Modacrylic, 40% cotton
- FR treated cotton lining
- Sto-nor 9801 FR reflective tape
- Seam sealed
- Detachable hood
- AS/NZS 4602.1:2011 Class D/N
- ATPV 32 cal/cm², PPE3



CODE	COLOURS	SIZES
WBJ8110T	Yellow/Navy, Orange/Navy	XS - 6XL

Bisley

TenCate Tecasafe® Plus 580 Taped Lightweight FR Trousers

- Tecasafe® Plus 580 AI FR Modacrylic, Lyocell, Aramid - 197gsm
- Cargo & standard style options
- Sto-nor 9801 FR reflective tape
- Back hip patch pocket with flap
- Seven reinforced belt loops
- AS/NZS 4602.1:2011 Class D/N
- ATPV 6 - 7 cal/cm², PPE1



CODE	DESCR.	COL.	SIZES
WBT8190T	Standard	Navy	77 - 112R, 87 - 132S
WBTC8189T	Cargo	Navy	

Bisley

TenCate Tecasafe® Plus 700 Taped FR Trousers

- Tecasafe® Plus 700 AI FR Modacrylic, Lyocell, Aramid - 238gsm
- Taped & untaped style options
- Back hip patch pocket with flap
- Seven reinforced belt loops
- Taped option includes Sto-nor 9801 FR reflective tape and AS/NZS 4602.1:2011 Class D/N
- ATPV 11 cal/cm², PPE2



CODE	DESCR.	COL.	SIZES
WBT8090	Untaped	Navy	77 - 112R, 87 - 132S
WBT8090T	Taped	Navy	

Bisley

TenCate Tecasafe® Plus 700 Taped FR Vented Cargo Trouser

- Tecasafe® Plus 700 AI FR Modacrylic, Lyocell, Aramid - 238gsm
- Taped & untaped style options
- Back yoke ventilation - TenCate FR Mesh - 152gsm
- LHS cargo pocket with flap and ruler pocket
- RHS mobile phone pocket
- Taped option includes Sto-nor 9801 FR reflective tape - AS/NZS 4602.1:2011 Class D/N
- ATPV 11 cal/cm², PPE2



CODE	DESCRIPTION	COLOURS	SIZES
WBTC8092	Mens Untaped	Navy	77 - 112R, 87 - 132S
WBTC8092T	Mens Taped	Navy	
WBTC8092T	Womens Taped	Navy	6 - 24

Portwest Portflame™/ Modaflame® Inherently Flame Resistant Clothing



Portflame™ HI VIS FR Anti-Static Shirt

- Viscose/aramid/anti-static Portflame® fabric - 185gsm
- Inherently flame resistant qualities will not diminish with washing
- Flame resistant reflective tape
- AS/NZS 4602.1: 2011 Class D/N
- ATPV 9.7 cal/cm² - ARC2



CODE	COLOURS	SIZES
WPS04FR	Yellow/Navy, Orange/Navy	S - 3XL



Modaflame® HI VIS FR Anti-Static Trouser

- Modacrylic/cotton/carbon Modaflame® fabric - 280gsm
- Inherently flame resistant qualities will not diminish with washing
- Flame resistant reflective tape
- 6 pocket design for ample storage
- Adjustable hem leg length
- ATPV 8.4 cal/cm² - ARC2



CODE	COLOURS	SIZES
WPT05FR	Navy	77 - 117, 79 - 84

Prime Mover PrimeTech™ Treated Flame Resistant Clothing



PrimeTech™ HI VIS FR Shirt

- Treated 100% cotton PrimeTech™ fabric - 185gsm
- Lightweight flame resistant protection
- Flame resistant reflective tape
- 2 chest pocket design
- Contrast two tone panels
- AS/NZS 4602.1: 2011 Class D/N
- ATPV 5.2 cal/cm² - ARC1



CODE	COLOURS	SIZES
WPS101FR	Yellow Navy, Orange/Navy	S - 5XL



PrimeTech™ HI VIS FR Trouser

- Treated 100% cotton PrimeTech™ fabric - 270gsm
- Flame resistant reflective tape option
- 6 pocket design for ample storage
- ATPV 8.3 cal/cm² - ARC2



CODE	DESCRIPTION	COL.	SIZES
WPT700FR	Cargo Trouser	Navy	77R - 112R, 87ST - 137ST, 79L - 94L
WPT701FR	Taped Cargo Trouser	Navy	79L - 94L

Elliotts ArcSafe® Protection Arc Flash Protection



ELLIOTTS

ArcSafe® T40 Arc Flash Switching Kit

T40 Coat

- ATPV rating - 40.4cal/cm²
- Inherently flame resistant
- HI VIS orange with taping available

T40 Gloves

- Designed to fit over electrical voltage gloves

T40 Hood

- Integrated hard hat

T40 Leggings

- 400mm in length

Kit also includes Safety Glasses and Kit Bag



CODE	DESCRIPTION	COLOUR	SIZES
CEAKT40	ArcSafe T40 Coat & Leggings Kit	Orange	S - 3XL

ELLIOTTS

ArcSafe® ArcFit 14™ Faceshield

- Combination head and face protection for arc flash hazards
- NFPA 70E PPE category protection levels 1 & 2
- ASTM F2178 Arc rating of 14cal/cm²
- Anti-scratch/anti-fog coated visor on both sides
- Light green visor tint with 55% visible light transmission
- Visors available with and without chin guard
- Kits include hard hat, visor holder, visor, dielectric eyewear and carry bag



HCV20K2

CODE	DESCRIPTION
HCV20K2	Elvex ArcFit Cap/Visor Combo c/w Chin Guard
VVG20K1	Elvex ArcFit Visor & Visor Holder c/w Chin Guard
VVG20	Elvex ArcFit Visor c/w Chin Guard



HI VIS Fluoro Day Vest

- Durable lightweight polyester fabric
- Fluoro orange and yellow options
- Velcro tab front fastening
- Compliant to AS/NZS 4602.1:2011 Class D



CODE	DESCRIPTION	COLOURS	SIZES
CV010	HI VIS Class D Vest	Orange, Yellow	S - 4XL



HI VIS Fluoro Day/Night Vest

- Durable lightweight polyester fabric
- Fluoro orange and yellow options
- Velcro tab front fastening
- H and X back reflective tape pattern options
- Compliant to AS/NZS 4602.1:2011 Class D/N



CODE	DESCRIPTION	COLOURS	SIZES
CV110	HI VIS Class D/N Vest - H Back	Orange, Yellow	S - 4XL
CV120	HI VIS Class D/N Vest - X Back	Orange, Yellow	S - 4XL



BACK

HI VIS VIC Roads Style Day/Night Vest

- Lightweight and comfortable 100% polyester fabric - 120g
- Tough plastic zipper closure
- Dipped back hem for improved coverage
- 3M microprism reflective tape - double stripe front & triple stripe rear
- Compliant to AS/NZS 4602.1:2011 Class D/N



CODE	DESCRIPTION	COLOURS	SIZES
CV338	Vic Roads Style HI VIS D/N Vest	Red	S - 5XL



HI VIS Pre-Printed Vests

- Pre-printed on centre back of vest for easy worker/visitor identification
- Lightweight and comfortable 100% polyester fabric - 120g
- Taped D/N versions use 3M reflective tape with tough plastic zipper closure
- Untaped D versions use large double strength quick stick fastener closure
- Compliant to AS/NZS 4602.1:2011 Class D (untaped) or D/N (taped)



BACK

HI VIS Cotton Day/Night Vest

- Lightweight 100% cotton fabric - 185gsm
- 3M reflective tape - double stripe front & triple stripe rear
- Plastic zipper and pulley closure
- Dipped back hem for improved coverage
- Compliant to AS/NZS 4602.1:2011 Class D/N



CODE	DESCRIPTION	COLOURS	SIZES
CV338C	HI VIS Cotton D/N Vest	Yellow Orange	S - 5XL S - 6XL



Pink Vest - Promotional

- 100% polyester - 120gsm
- Vertical touch tape front fastening
- Back tail drops down to cover lower back
- Please note: Pink colourway does not comply to daytime HI VIS standards AS/NZS1906.1:2010



CODE	DESCRIPTION	COLOURS	SIZES
CV0345PK	Pink Vest - Non Approved	Pink	S - 6XL



CODE	DESCRIPTION	COLOURS	SIZES
CV116	Pre-printed HI VIS D Vest (specify print)	Orange, Yellow	S - 5XL
CV102Z	Pre-printed HI VIS D/N Vest (specify print)	Orange, Yellow	S - 5XL



Zero Light and Cool Chainsaw Chaps

- Arrestex HP advanced chainsaw protection material
- Full protection from waist to the ankle - clip fastening
- Lightweight, breathable, high-tenacity outer covering with soft poly cotton lining
- HI VIS panels
- 50mm wide belt with quick release buckle
- Certified to AS/NZS 4453.3:1997



CODE	SIZES
CLC271C	S fits inseam 76-81 cm (30-32 inch) M fits inseam 81-86 cm (32-34 inch) L fits inseam 86-91 cm (34-36 inch)



DefenderPRO Chainsaw Trousers

- Arrestex HP advanced chainsaw protection material
- Durable 4-way stretch nylon/lycra outer with mesh lining
- 2 large pockets
- Elasticised waist
- Fixed or zip vents
- HI VIS segmented reflective tape - meets AS/NZS 4602.1:2011
- Certified to AS/NZS 4453.3:1997



CODE	DESCRIPTION	SIZES
CLT21DPF	DefenderPRO Fixed Vents	2XS - 3XL
CLT21DPZ	DefenderPRO Zip Vents	2XS - 3XL



Zero Gen2 Chainsaw Trousers

- Arrestex HP advanced chainsaw protection material
- Very lightweight at only 1kg
- High tenacity 4-way stretch nylon/lycra outer - uses Nilit® Breeze yarn
- Hi VIS panels front and rear plus cooling vents
- 4 hip and thigh pockets
- Certified to AS/NZS 4453.3:1997



CODE	DESCR.	COLOURS	SIZES
CLT71Z	Men's	Orange, Grey/Green	XS - 2XL
CLT71ZW	Women's		2XS - 2XL



Arcmax Arc Rated Fire Resistant Chaps

- Arrestex FR fire resistant chainsaw protection material
- ENA NENS 09-2014 for arc protection
- Nomex®/fire resistant viscose ripstop outer fabric
- FR reflective tape and lining
- 50mm wide belt with quick release buckle
- Certified to AS/NZS 4453.3:1997
- ATPV 8.2 cal/cm²



CODE	SIZES
CLC61F	S fits inseam 76-81 cm (30-32 inch) M fits inseam 81-86 cm (32-34 inch) L fits inseam 86-91 cm (34-36 inch)



Defender C8 Clipped Style Chainsaw Chaps

- Arrestex chainsaw protection material
- Split front design with 50mm belt and quick release buckle - 4 clip fastening
- Front chainsaw protection from the hip to ankle
- 600D oxford weave outer with soft polycotton lining
- 50mm wide belt with quick release buckle
- Certified to AS/NZS 4453.3:1997



CODE	SIZES
CLC81C	S fits inseam 76-81 cm (30-32 inch) M fits inseam 81-86 cm (32-34 inch) L fits inseam 86-91 cm (34-36 inch)



Line Trimmer Chaps

- Protects the lower legs from flying debris and stones
- Suitable for use with line trimmers, brush cutters, lawnmowers and other landscaping power tools
- Hard wearing polyester outer
- Soft polycotton lining
- Fastens with 4 hook-and-loop elastic straps
- One size fits all



CODE	COLOURS	SIZES
CLCL21M	Navy, Green	One size fits all



Chainsaw Arm Protector

- Protects arm from the elbow to the wrist
- Elastic cuff
- Hook and loop tab to hold sleeve secure
- Made with Arrestex HP advanced chainsaw protection fabric
- Heavy duty polycotton drill outer
- Certified to AS/NZS 4453.3:1997



CODE	SIZES	UOM
CSLAP31	S (24cm length), M (26cm length), L (28cm length)	Ea



Chainsaw Gloves

- Constructed from cowhide leather with HI VIS nylon back
- Designed to protect the back of the left hand from chainsaw cuts
- Reinforced palm area & elasticised cuff
- EN388:2003 2232
- CE marked to comply with EN381-7:1999 for chainsaw protection to Class 0 (16m/s) level



CODE	SIZES	UOM
GCRGA1	S - XL	Pair

3M

Protective Coverall 4510

- Protection against dry particles and certain limited liquid chemical splash (CE Type 5/6)
- Laminated micro-porous material
- 2-way zipper with storm flap
- Elastic hood, cuffs, waist and ankles
- Super low-linting 47gsm fabric
- Anti-static treatment to EN 1149 on inner surface
- Biological protection tested to EN 14126



CODE	COLOURS	SIZES	UOM
CD04510	White	M - 3XL	Ea

3M

Protective Coverall 4515

- Protection against dry particles (including asbestos) and certain limited liquid splash (CE Type 5/6)
- Robust, highly breathable SMS material
- 2-way zipper with storm flap
- Elastic hood, cuffs, waist and ankles
- Low-linting 50gsm fabric

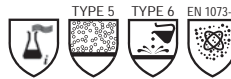

CODE	COLOURS	SIZES	UOM
CD04515	White, Orange	M - 3XL	Ea
	Blue	L - 3XL	Ea

3M

Protective Coverall 4532+

- Made from a breathable and lightweight 5-layered SMMMS material providing CE Type 5/6 protection
- Low-linting 52gsm fabric
- Specialist treatments providing anti-static protection and an enhanced liquid hold-out from alcohol and oil repellence
- Enhanced & reinforced triangular gusset panel
- 2-way zipper with storm flap
- Knitted cuffs and elastic hood, waist & ankles
- Anti-static treatment to EN 1149



CODE	COLOURS	SIZES	UOM
CD04532	Blue	M - 3XL	Ea

3M

Protective Coverall 4535

- Protects against dry particles and certain limited liquid chemical splash (CE Type 5/6)
- Dual material design: front made from polyethylene laminate, extra large blue back panel made from breathable 5 layer spunbond polypropylene
- 2-way zipper with storm flap
- Knitted cuffs and elastic hood, waist and ankles
- Low-linting 55gsm fabric
- Anti-static treatment to EN 1149 on inner surface (white material only)



CODE	COLOURS	SIZES	UOM
CPO4535	White/Blue	M - 2XL	Ea

3M

Protective Coverall 4540+

- Protects against dry particles and certain liquid chemical splash (CE Type 5/6)
- Composite layer of spunbond fibres and a layer of polyethylene laminate film
- Back panel: breathable SMMMS material
- Super low-linting
- 2-way zipper with sealable storm flap
- Knitted cuffs and elastic hood, waist and ankles
- Anti-static treatment to EN 1149 on inner surface (white material only)



CODE	COLOURS	SIZES	UOM
CPO4540	White/Blue	M - 3XL	Ea

3M

Protective Coverall 4570

- Excellent barrier for jet spray and liquid tight chemical protection (CE Type 3/4/5/6 levels)
- Material blends soft inner layers with multiple outer layers of a high performance anti-static treated (on inner surface) polyethylene laminate
- Super low-linting
- Large double zip entry with double storm flaps
- Stitched and taped seams
- Elastic hood, cuffs, waist and ankles



CODE	COLOURS	SIZES	UOM
CPO4570	Grey	M - 3XL	Ea

3M

Protective Overboot 450

- Laminated material minimises particle shed and contamination
- Ideal for cleanrooms
- PVC slip resistant sole
- Universal size with ties
- Elastic at the calf



CODE	COLOURS	SIZES	UOM
CDF450	White	One size fits all	Ea

3M

VFlex™ P2 Disposable Respirator

- Folded v-shaped pleats that expand
- Side tabs act to assist with fit
- Available in a handy and compact box



CODE	DESCRIPTION	UOM
RD1804	VFlex Particulate Respirator 1804, P2 Standard Size	Box/50
RD1804S	VFlex Particulate Respirator 1804S, P2 Small Size	Box/50



Eco PP Overall

- Single layer non-woven polypropylene
- Lightweight, cool and breathable
- Economical protection against particulate matter, fibres, dirt, dust, grease and grime
- Elasticised hood, waist, ankles and wrists
- Two-way zipper



CODE	COLOURS	SIZES	UOM
CDO55	White, Navy	M - 3XL	Ea



Hazgard SMS Overall

- CE Type 5 & 6 protection against particulate materials & dusts and limited splash & liquid spray
- Suitable for asbestos use
- Two way zipper
- Highly breathable, reduces heat stress
- Triple layer non woven polypropylene matrix
- Elasticised hood, waist, ankles and wrists



CODE	COLOURS	SIZES	UOM
CDO70	White, Blue	M - 3XL	Ea



Hazgard MP4 Overall

- CE Type 4, 5 & 6 protection against liquid spray, particulate materials & dusts and limited splash & liquid spray
- Breathable, water resistant, microporous
- Excellent abrasion and tear resistance
- Lint-free outer surface
- Stitched and taped seams for waterproof seal
- Elasticised hood, cuffs, waist and ankles
- Two-way zipper
- Anti-static to EN 1149-1:1195



CODE	COLOURS	SIZES	UOM
CDO35	White	M - 3XL	Ea



Hazgard MP5 Overall

- CE Type 5 & 6 protection against particulate materials & dusts and limited splash & liquid spray
- Breathable, water resistant, microporous
- Lint-free outer surface
- Stitched seams for greater strength
- Excellent abrasion and tear resistance
- Anti-static to EN 1149-1:1195



CODE	COLOURS	SIZES	UOM
CDO30	White	M - 3XL	Ea



Hazgard Chem 3 Chemical Suit

- Chemical protection against pressurised liquid chemicals, liquid spray and airborne particulates - CE Type 3/4/5
- Protects against biological hazards and infective agents
- Anti-static material consists of a yellow external barrier film and a layer of spunbonded polypropylene
- Stitched seams, sealed with chemical proof tape
- Double layer storm flaps
- Chin strap

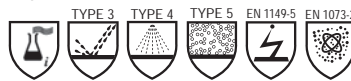

CODE	COLOURS	SIZES	UOM
CPO5154	Yellow	L - 2XL	Ea



Disposable Lab Coats & Aprons

- Water resistant & waterproof options
- Lightweight fabrics
- Dry and wet area options



CDL003

CDA800

CODE	DESCRIPTION	COL.	UOM
CDL003	Lab Coat No Pockets	White	Ctn/50
CDL009	Lab Coat No Pockets	Blue	Ctn/50
CDA800	Apron LDPE Water-proof 800x1400mm	White	Disp. Box/50
CDA800B	Apron LDPE Water-proof 800x1400mm	Blue	Disp. Box/50



Disposable Accessories

Armguard Sleeves

- Water resistant polyethylene (PE)

Lighttouch Sleeves

- Breathable polypropylene (PP)



CDSL02

CDSL03

Shoe & Boot Covers

- Lightweight fabrics
- Elasticated tops
- Dry and wet area options



CDF300

CDF330

CDF310

Disposable Caps & Beard Cover

- Lightweight, comfortable PP caps and beard covers
- Round or crimped cap styles
- Beard covers have double loop



CDC01



CDB01

CODE	DESCRIPTION	COLOURS	UOM
CDSL02	Armguard PE Sleeves 40cm	Blue, White	Ctn/2000
CDSL03	Lighttouch PP Sleeves 40cm	Blue, White	Ctn/500
CDF300	Surefoot Dry Area PP Shoe Cover	Blue	Ctn/500
CDF310	Gloshie Water Resistant CPE Shoe Cover	Blue, White	Ctn/1000

CODE	DESCRIPTION	COLOURS	UOM
CDF330	CPE Waterproof Boot Cover	White	Pk/50
CDC01	Round Cap 21"	White, Blue	Ctn/1000
CDC02	Crimped Cap 21"	White, Blue	Ctn/1000
CDB01	Beard Cover	White, Blue	Ctn/500

DUPONT

Tychem® 6000 F Protective Coverall

- DuPont™ Tychem® 6000 F, model CHZ5
- Chemical protective clothing to CE Type 3-B/4-B/5-B/6-B
- Stitched and over-taped seams
- Elastication at hood, wrists, ankles, face & waist
- Double zippers & flaps, double cuffs
- EN 14126 (infective agents), EN 1073-2 (radioactive contamination)
- Anti-static treatment (EN 1149-5) on inside



CODE	COLOURS	SIZES	UOM
CPOT70	Grey	M - 3XL	Ea

DUPONT

Tychem® C Protective Coverall

- Lightweight, durable Tyvek® fabric with a polymeric barrier
- Chemical protective clothing to CE Type 3-B/4-B/5-B/6-B
- Stitched and over-taped seams
- Double self-adhesive zipper flap
- Elastication at wrists, ankles, face & waist
- EN 14126 (infective agents), EN 1073-2 (radioactive contamination)
- Anti-static treatment (EN 1149-5) on inside



CODE	COLOURS	SIZES	UOM
CPOT50	Yellow	M - 3XL	Ea

DUPONT

Tyvek® 500 HV Protective Coverall

- Made from breathable non woven flash spun polyethylene
- Protective clothing to CE Type 5-B/6-B
- Collared HI VIS orange coverall with reflective tape
- Elastication at wrists, ankles, face & waist
- Stitched external seams
- Tyvek® auto-lock zipper and zipper flap
- EN 14126 (infective agents), EN 1073-2 (radioactive contamination)
- Anti-static treatment (EN 1149-5) on inside



CODE	COLOURS	SIZES	UOM
CDOT25	Orange	M - 3XL	Ea

PRO

PROVEK™ Seam Sealed Disposable Coverall

- Light and durable microporous film laminated PPSPB
- Protection to CE Type 4/5/6, plus EN 14126 (infective agents) and EN 1073-2 (radioactive contamination)
- DIN 32781 (pesticides), EN 1149-5 anti-static
- 3-panel hood is designed to fit when wearing respirator and goggles
- Elasticated hood, ankles, cuffs and waist
- Optimised body fit for improved comfort
- Air and water vapour permeable
- Two way zipper
- Silicone free



CODE	COLOURS	SIZES	UOM
CDOWT	White	S - 4XL	Ea

PRO

PROVEK™ Disposable Coverall

- Polyethylene (Olefin) film laminated polypropylene spun bound non woven substrate
- Protection against dust and a broad range of chemicals to CE Type 5/6
- Breathable, lightweight soft fabric with excellent strength
- Water vapour permeable and water repellent
- Elastic hood face, waist, cuff and ankles
- Two way zipper
- Lint free



CODE	COLOURS	SIZES	UOM
CDO90	White	S - 4XL	Ea

PRO

Single Layer Disposable Coverall

- Lightweight single layer polypropylene material
- Durable and economical
- Elastic waist, cuffs and ankles
- Two way zipper



CODE	COLOURS
CDO80	White, Blue
SIZES	UOM
M - 3XL	Ea

PRO

SMS Disposable Coverall

- Triple layer protection to CE Type 5/6
- Lightweight material with excellent strength
- Elastic hood face, waist, cuff and ankles
- Water vapour permeable
- Two way zipper
- Lint free



CODE	COLOURS
CDO85	Blue, White, Orange
SIZES	UOM
M - 4XL	Ea

PRO

Calico Spray Hood

- Lightweight calico fabric
- Elasticised face opening for a secure sealed fit
- Ideal for spray painting



CODE	COLOURS	SIZES	UOM
HH7658	White	One Size	Ea



Freezer Jacket & Pants

- Polyester 300D Oxford weave, PU coated waterproof - 190g
- Polyester lined and padded
- Taped seams

Jacket

- Elasticated back waist
- Fur lined collar
- Concealed detachable hood
- Inner knitted cuffs
- AS/NZS 4602.1 Class D/N

Trouser

- Drawcord adjustable waist
- Full length zipped sides with touch tape flap closure
- 2 pockets, concealed touch tape fastening



CODE	DESCRIPTION	COLOURS	SIZES
CFJ8044	Huski Freezer Jacket	Yellow/Green	S - 5XL
CFT8047	Huski Freezer Trousers	Yellow/Green	S - 5XL

THORZT

Evaporative Cooling Slip-Over Vest

- When wet, stays cool while you're active
- Simple slip over vest, velcro side fastening for comfort
- Comfortable, quilted polyester outer with unique polymer cooling fabric inner
- Hand washable - doesn't effect cooling
- Lightweight and durable
- One size fits all



CODE	DESCRIPTION	COLOURS	SIZES	UOM
CVTCSOV	Thorzt Cooling Slip-Over Vest	Blue, Black, Orange, Silver, Yellow	One size	Ea



CV01 Evaporative Cooling Vest

- Constructed from an innovative PVA multi-layered fabric
- Unique polymer chemistry activates with water submersion
- Keeps the wearer cool for up to 8 hours
- Wicking, cooling and drying capabilities
- Front zip opening
- Polyester mesh fabric with bamboo yarn and PVA padding



CODE	DESCRIPTION	COLOURS	SIZES	UOM
CVT01	Cooling Vest	Grey	One Size	Ea
HMCV03	Cooling Crown	Orange/Blue	One Size	Ea



Beanies & Glove

Beanies

- Polar fleece or acrylic knit options
- Insulatex lined options
- USB rechargeable LED head light option

Freezer Glove

- Crinkle latex palm dip for excellent grip
- Warm 10 gauge acrylic liner
- EN388 - 1141
- EN511 - X1X



CODE	DESCRIPTION	COLOURS	SIZES
CB602	Fleece Beanie	Orange, Yellow, Green, Navy	S/M, L/XL, 2XL/3XL
CB010	Insulatex Fleece Beanie	Black, Navy, Yellow	One Size
CB029	LED Knit Beanie	Black, Navy, Orange, Yellow	One Size
CB013	Insulatex Knit Beanie	Black, Navy, Orange	One Size
GTC140	Thermal Grip Glove	Yellow/Black Orange/Black	S - 2XL M - 2XL

THORZT

Cooling Apparel

- Promotes thermoregulation
- Reduces heat stress risks
- Submerge in water to activate
- Use over and over again
- Cap, Towel and Scarf are machine washable



CODE	DESCRIPTION	COLOURS	SIZES	UOM
HMOOCCT	Thorzt Cooling Cap	Black, Royal Blue	One Size	Ea
CCTCSB	Thorzt Cooling Towel	Blue	75 x 32cm	Ea
HMOOCT	Thorzt Cooling Tie	Black, Royal Blue	One Size	Ea
HMOOCST	Thorzt Cooling Scarf	Khaki, Orange, Yellow, Royal Blue	One Size	Ea



Phase Change Cooling Vest

- Vest incorporates flexible ice blanket inserts
- Supplied with a set of 4 inserts
- Effective cooling time up to 3 hours
- Taped or untaped
- Insulated 'Sof-Pac' storage and transport containers for inserts available



CODE	DESCRIPTION	COLOUR	SIZES	UOM
CV725	HI VIS Vest Cotton c/w Inserts	Yellow, Orange	M, L, XL	Ea
CV700	Vest Cotton c/w Inserts	Blue	M, L, XL	Ea
CVX775	Replacement Inserts	-	-	Set/4

ELLIOTTS

Golden Chief® Premium Welding Jacket

- Lightweight premium pig split leather
- Inside pocket & sleeve pen pockets
- Press stud closure
- Side adjusters for snug fit
- Adjustable cuffs
- Corduroy lined collar
- Bolero & Apron style option
- Riveted wear areas & aramid thread



CODE	DESCRIPTION	SIZES
CWJGC30	Golden Chief Jacket 730mm Length	S - 4XL
CWBAGC	Golden Chief Bolero & Apron	S - 4XL
CWSPGC	Golden Chief Welder's Spats	One Size

ELLIOTTS

Wakatac® Proban® Welding Jacket c/w Leather Sleeves

- Front and back protection
- Chrome leather sleeves
- Longer length at the back for extra protection
- Velcro® front & side closure
- Lightweight and cool
- Quarter back jacket option



CODE	DESCRIPTION	SIZES
CWJW30LS	Wakatac Proban Jacket, Leather Sleeves	S - 4XL
CWJW30LSQB	Wakatac Proban Jacket, Leather Sleeves Quarter Back	S - 4XL
CWHW30	Wakatac Proban Hood	One Size

ELLIOTTS

Blue Max® Chrome Leather Welding Jacket

- Chrome leather for heavy duty protection from dross & spatter
- Sized to fit over normal work clothes
- Press stud closure
- Stand-up collar
- Trousers options available



CODE	DESCRIPTION	SIZES
CWJ128	Chrome Leather Jacket	S - 4XL
CWT10	Big Red Leather Seatless Trousers	M - 2XL
CWT2	Big Red Leather Trousers	M - 2XL

PRO
PROFESSIONAL SAFETY GEAR

Pyromate® Red Welder's Jacket

- High quality red cow split leather
- Resistant to heat, cuts & abrasion
- Staggered double studs to ensure a secure fit
- Aramid stitched
- Moderate heat protection



CODE	DESCRIPTION	SIZES
CWJ810	Red Welder's Jacket	M - 3XL
CWS3	Red Welder's Sleeves	One Size
CWSP05	Welder's Spats	L - XL

PRO
PROFESSIONAL SAFETY GEAR

Pyromate® Welder's Jacket

- Pyrovatex® treated cotton drill for enhanced breathability
- Aramid stitched with chrome leather sleeves
- VELCRO® brand fastenings
- Collared neck
- Lightweight and cool



CODE	DESCRIPTION	SIZES
CWJPVJ	Drill Welder's Jacket	L - 3XL
YWBL1818	Leather Welder's Blanket	1.8 x 1.8m

ELLIOTTS

ArcSafe® Welding Screens

- Absorbs dangerous ultraviolet light
- Surrounds welding areas with safety - prevents accidental welding flash
- Welded seams with eyelets at 200mm on four sides
- Range of colours/sizes available
- Certified to Australian Standard AS 3957/NZ 5852:2006



FRAME NOT INCLUDED - SCREEN ONLY

CODE	DESCRIPTION	COLOURS	UOM
YWSA1813	Welding Screen 1.8m x 1.3m	Red, Green	Ea
YWSA1818	Welding Screen 1.8m x 1.8m	Red, Green	Ea



Pyromate® Welder's Hood

- Fire retardant
- Pyrovatex treated cotton drill for enhanced breathability
- Side gussets for a comfortable fit
- Drawstring face closure for extra protection



CODE	COLOURS	SIZE	UOM
CWHPVHM	Maroon	One Size	Ea



Proban® Welder's Hood

- Proban® treated drill fabric
- Side gussets for comfort
- Drawstring face closure for extra protection



CODE	DESCRIPTION	SIZE	UOM
CWHP30B	Blue Max Proban Hood	One Size	Ea
CWHP30Y	Orange Proban Hood	One Size	Ea



Tyvek® Hood

- Tyvek® flash spun high density polyethylene
- Pullover hood design
- Elastic neck & face opening for good fit around PAPR



CODE	COLOURS	SIZE	UOM
CDHT20	White	One Size	Ea



Industrial PVC Apron

- 90cm x 120cm PVC apron - 0.8mm
- Blood, animal oils and fats resistant
- Abrasion resistant
- Limited chemical resistant
- Flexible, light and tough
- Neck and waist ties



CODE	COLOURS	UOM
CAP300	Black, Blue, White	Ea



Industrial Leather Aprons

- Grey chrome leather aprons
- Easy on and off limits transfer of contaminants between work areas
- Buckle and leather strap for easy fitting



CODE	DESCRIPTION	UOM
CAL96	Apron 900 x 600mm	Ea
CAL108	Apron 1000 x 800mm	Ea



Protective Knee Pads

Proflex

- Non-slip, non-marking soft shell
- Suitable for use on all interior floors



CKPSS

ProComfort

- Non-slip, non-marking soft synthetic leather shell
- Suitable for use on all interior floors



CKPLS

Turtle Back

- Hard shell for easy swivelling and durability
- Gel padding back and sides enhances comfort and assists in even weight distribution



CKPHS

CODE	DESCRIPTION	UOM
CKPSS	Proflex Knee Pad Soft Shell	Pair
CKPLS	ProComfort Knee Pad Synthetic Leather	Pair
CKPHS	Turtle Back Knee Pad Hard Shell	Pair



Back Support Belt

- Adjustable belt and braces for a comfortable fit
- Smooth-glide adjustable clips
- Tapered abdomen support panels
- 35mm wide support elastic braces



CODE	DESCRIPTION	SIZES	UOM
XBB	Back Support Belt	S - 2XL	Ea



SnakeSafe Snake Gaiters

- Super-tightly woven penetration resistant fabrics
- Protection from the knee to the ankle
- Zip fastens from the top to the bottom, making them easy to get on
- Straps under the boot keep the SnakeSafe gaiter in position
- Water resistant and lightweight
- Ideal for recreational or professional use



CODE	DESCRIPTION	SIZES	UOM
CLSSG31	SnakeSafe Snake Gaiters	S - XL	Pair

CARIBEE

HI VIS Gear Bags

Kokoda Bag - 90L

- HI VIS duffle bag made of heavy duty tarpaulin
- End haul handles
- Heavy duty 2" webbing
- Removable padded shoulder straps convert bag to back pack
- 3 internal mesh pockets



MBG5807
KOKODA

Bunker Bag - 60L

- Heavy duty HI VIS gear bag with reflective tape
- Large main storage pocket with oversized dual zipper opening for easy access
- Twin full height end zip pockets
- Detachable webbing



MBG5782
BUNKER

Century Bag - 42L

- HI VIS polyester/PVC industrial style barrel bag
- Twin zip opening
- Reflective X pattern tape on both end panels



MBG5800
CENTURY

CODE	DESCRIPTION	COLOURS	UOM
MBG5807	Kokoda Tarpaulin Bag 90L - 70x40x40cm	Orange	Ea
MBG5782	Bunker Gear bag 60L - 60x30x35cm	Orange	Ea
MBG5800	Century Barrel Bag 42L - 60x30x30cm	Orange	Ea

CARIBEE

HI VIS Back Packs

Pilbara Back Pack - 34L

- Heavy duty HI VIS back pack c/w reflective X pattern tape
- Reflective Air Flow padded harness system
- Twin main zippered storage compartments
- Fold-over safety flap with reflective tape



MBP11802
PILBARA

SwitchBack Back Pack - 32L

- Heavy duty HI VIS back pack c/w reflective tape
- Padded harness system with sternum strap
- Twin compartment design
- Hydration ready - just add 2L or 3L reservoir



MBP5780
SWITCHBACK

Mineral King Back Pack - 32L

- Heavy duty HI VIS back pack c/w tape
- 'Bio Form' harness system
- Utility hip belt & sternum strap
- Specialty pockets and compartments



MBP6476 MINERAL KING

CODE	DESCRIPTION	COLOURS	UOM
MBP11802	Pilbara Back Pack 34L - 44x33x24cm	Orange, Yellow	Ea
MBP5780	SwitchBack Back Pack 32L - 50x32x22cm	Orange	Ea
MBP6476	Mineral King Back Pack 32L - 50x32x20cm	Orange	Ea



Gear Bags

B907 Multi-Pocket Trolley Bag

- In-line wheel system
- Robust base panel
- Telescopic handle
- Padded double straps
- Multiple zip compartments
- ID card holder
- Polyester/PVC coated



MBG907

B909 Travel Trolley Bag

- In-line wheel system
- ID card holder
- Telescopic handle
- Polyester 600D fabric



MBG909

CODE	DESCRIPTION	COLOURS	UOM
MBG907	B907 Trolley Bag 100L - 60x40x42cm	Black/Red	Ea
MBG909	B909 Trolley Bag 100L - 76x37x36cm	Black	Ea



HI VIS Rucksacks

- Polyester 600D fabric
- Premium reflective tape for increased visibility
- Padded double straps for added support
- Padded back panel for wearer comfort
- Phone pocket
- Quick release buckle option



MBP904



MBP905

CODE	DESCRIPTION	COLOURS	UOM
MBP904	B904 Quick Release Rucksack 25L - 28x21x43cm	Orange	Ea
MBP905	B905 Rucksack 25L - 28x21x43cm	Orange, Yellow	Ea



Safety Kit Bag

- Duffel-style kit bag
- ID window
- Robust carry handles and shoulder strap



CODE	DESCRIPTION	COLOURS	UOM
MBGSKB	Duffel Kit Bag - 61x31x31cm	Black	Ea



Arax® Cut 5 Protective Sleeves

- Arax® Knit Technology
- 35cm length
- Protects forearms from cuts and abrasions
- Contact heat resistant to 100 °C
- EN388 4X4XD
- EN407 X1XXXX



CODE	DESCRIPTION	SIZES	UOM
CSLA5SLE35	Arax® Cut Resistant Sleeve	One Size	Pair



SAFETY FOOTWEAR

APPLICATION

AS/NZS 2210.1:2010 recommends that safety footwear should be worn to reduce foot injuries caused by contact with moving or falling objects, sharp materials that may penetrate through the sole or uppers, friction, contact with chemicals, heat, molten metals, slipping and electrical hazards.

RISK ASSESSMENT

A risk assessment identifying all possible foot hazards is essential before implementing a footwear protection programme. It is important to note that safety footwear can only provide a limited degree of protection against hazards in the workplace.



FOOTWEAR SELECTION ELEMENTS

SOLE	
Rubber	Heat resistant to 300°C
TPU	Heat resistant to 130°C - 140°C
PU	Heat resistant to 130°C - 140°C
PVC	Waterproof, oil/fat/acid resistant
TOE CAPS	
Steel	200 Joules/1500 Newtons
Composite	200 Joules/1500 Newtons
ELECTRICAL RESISTANCE	
Anti-static	Allows static electricity to earth
Conductive	Allows mains & static electricity to earth
Insulating	Protects against high voltage
OTHER	
Metatarsal Guard	Protects the metatarsal bones of the foot
Steel Midsole	Penetration resistant layer imbedded into the sole

Typical hazards may include:

- Slipping due to surface type & condition and wet or dry state (including type of liquid)
- Dropped or falling objects causing crushing or cutting injuries
- Moving plant and equipment causing crushing injuries
- Sharp objects with the potential to puncture or penetrate
- Exposure to extremes of temperature including welding and hot metal operations
- Chemical spills and other hazardous or toxic substances
- Unsafe electrical equipment
- Static electricity discharge can cause harm to workers and equipment
- Uneven terrain
- High levels of physical activity and duration of shifts causing foot soreness/discomfort

SAFETY TIPS

- Correct fitting is essential to comfort and good foot health.
- If orthotics, arch supports and other inserts are necessary ensure fitting considers these requirements.
- Fitting is best conducted whilst standing and later in the day to allow for working conditions.
- Keep footwear clean and well maintained to ensure effectiveness.
- Good quality socks assist with comfort and overall foot hygiene if replaced daily.

All workers should be trained in the correct use and maintenance of personal protective equipment.

USEFUL REFERENCES

AS/NZS 2210.1:2010 Safety, protective and occupational footwear - Guide to selection, care and use.

LEATHER FOOTWEAR	68
PVC FOOTWEAR	75
ACCESSORIES	76



by Honeywell



AT's 55 Series

- Water resistant leather
- 'TECTuff' toe & heel guard
- Dual density PU/Rubber sole, anti-static, heat resistant to 300° C
- Shock absorbing polyurethane midsole
- 'NANOlite' footbed for enhanced comfort and reduced odour
- Aramid thread on critical wear seams



FO55332Z



FO55322



FO55320



FO55332



FO55336



FO55337



FO55345



FO55345Z

CODE	STYLE	COLOUR	SIZES
FO55322	Elastic Sided Boot	Wheat	4-14, 6½-12½
FO55320	Elastic Sided Boot	Black	4-14, 6½-12½
FO55332	150mm Lace-up Boot	Wheat	4-14, 6½-12½
FO55332Z	150mm Lace-up/Zip Sided Boot	Wheat	4-14, 6½-12½
FO55336	150mm Lace-up Boot, Metatarsal	Wheat	4-14, 6½-12½
FO55337	150mm Lace-up Boot	Claret	4-14, 6½-12½
FO55345	150mm Lace-up Boot	Black	4-14, 6½-12½
FO55345Z	150mm Lace-up/Zip Sided Boot	Black	4-14, 6½-12½
FO55346	150mm Lace-up Boot, Metatarsal	Black	4-14, 6½-12½
FO55385	High Leg Lace-up/Zip Sided Boot	Wheat	4-14, 6½-12½



FO55346



FO55385



by Honeywell



AT's 45 Series

- Water resistant leather
- 'NATUREform' wide profile high impact non-metallic composite toe cap
- Dual density PU/TPU sole, heat resistant to 130° C
- Shock absorbing polyurethane midsole
- Fully lined with padded comfort collar and tongue (lace up styles)



FO45632



FO45627



FO45632Z



FO45637

CODE	STYLE	COLOUR	SIZES
FO45632	Lace-up Mid Cut Boot 150mm	Wheat	5-14, 6½-10½
FO45627	Elastic Sided Boot	Brown	5-14, 6½-10½
FO45632Z	Zip Sided Mid Cut Boot 150mm	Wheat	5-14, 6½-10½
FO45637	Lace-up Mid Cut Boot 150mm	Brown	5-14, 6½-10½
FO45645	Lace-up Mid Cut Boot 150mm	Black	5-14, 6½-10½
FO45645Z	Zip Sided Lace-up Mid Cut Boot 150mm	Black	5-14, 6½-10½



FO45645



FO45645Z

OLIVER safety footwear conforms to AS/NZS 2210.3



34 Series Dual Density Footwear

- Griphane® dual density polyurethane sole
- Slip resistant and heat resistant to 130 °C
- Water resistant leather uppers
- AEGIS Microbe Shield® comfort footbed
- COMFORTcushion® Impact Absorption System with PORON
- NATUREform® safety steel toe cap



CODE	STYLE	COLOUR	SIZES
FO34626	Elastic Sided Leather Boot	Claret	4-13, 6½-10½
FO34610	Slip-on Nubuck Leather Shoe	Black	4-13, 6½-10½
FO34613	Suede Lace-up Safety Jogger	Black	4-13, 6½-10½
FO34615	Slip-on Nubuck Leather Shoe	Wheat	4-13, 6½-10½
FO34620	Elastic Sided Leather Boot	Black	4-13, 6½-10½
FO34623	Suede Lace-up Ankle Jogger	Black	4-13, 6½-10½
FO34624	Elastic Sided Suede Boot	Beige	4-13, 6½-10½

CODE	STYLE	COLOUR	SIZES
FO34632	Lace-up Nubuck Leather Boot	Wheat	4-13, 6½-10½
FO34634	Lace-up Leather Boot	Black	4-13, 6½-10½
FO34652	Lace-up Derby Leather Shoe	Black	4-13, 6½-10½
FO34660	Zip Sided Ankle Boot	Black	4-13, 6½-10½
FO34662	Zip Sided Ankle Boot	Wheat	4-13, 6½-10½
FO34674	High Leg 190mm Zip Side Boot	Beige	4-13, 6½-10½
FO34692	Pull-on Rigger Boot	Brown	4-13, 6½-10½



44 Series Dual Density Footwear

- Dual density PU/TPU sole, heat resistant to 130 °C
- Padded collar and tongue
- Heel protection guard
- High impact non-metallic composite toe cap



CODE	STYLE	COLOUR	SIZES
FO44535	Lace-up Boot	Blue/Grey	5-14, 6½-10½
FO44500	Lace-up Shoe	Black	5-14, 6½-10½
FO44515	Lace-up Shoe	Black/Grey	5-14, 6½-10½

OLIVER safety footwear conforms to AS/NZS 2210.3



by Honeywell



FO49432Z



FO49445Z



FO49414



FO49430

49 Series Women's Dual Density Footwear

- Specifically designed last to support the shape of a female foot
- Dual density PU/Rubber sole with lightweight shock absorbing PU midsole
- Water resistant leather upper
- Oliver SOFTstride® insole support
- Anti-static sole
- Heat resistant outsole to 300°C
- NATUREform® wide profile steel safety toe cap
- Oliver COOLstep® lining to absorb moisture and odour
- COMFORTcushion® Impact Absorption System with PORON®

CODE	STYLE	COLOUR	SIZES (METRIC)
FO49432Z	Lace-up Boot Zip Side	Wheat	35-42
FO49445Z	Lace-up Boot Zip Side	Black	35-42
FO49414	Jogger Lace-up	Grey/Blue	35-42
FO49430	Slip-on Shoe	Black	35-42



by Honeywell



FO38275



FO38250



FO38265

38 Series Footwear

- Lightweight dual density polyurethane sole
- Premium soft touch waterproof leather
- COMFORTcushion® Impact Absorption System with PORON®
- NATUREform® wide profile steel toe cap
- Footbed infused with ecofriendly Odorban™
- Oliver SOFTstride® insole support
- Excellent slip resistant sole rated SRC
- Anti-static sole
- Heat resistant outsole to 130°C

CODE	STYLE	COLOUR	SIZES
FO38275	Executive Shoe	Black	6-13, 6½-10½
FO38250	Executive Pull-on Boot	Black	6-13, 6½-10½
FO38265	Executive Zip Side Boot	Black	6-13, 6½-10½



by Honeywell

INSOL-N Nanolite Footbed

- PORON heel and ball of foot inserts for exceptional comfort
- Shaped PU footbed
- Removeable & washable
- Resistant to odours
- Massages your feet as you walk



CODE	DESCRIPTION	SIZES
FGX600	INSOL-N Nanolite Footbed	4 - 14



by Honeywell



FO65791



FO65493



FO65490

AT65 Series Mining & Caustic Resistant Footwear

Mining Boot

- 100% waterproof premium full grain leather
- New Y-Guard TPU ankle protectors provides impact resistance
- Flush, integrated zip contours
- Heavy duty Aramid stitching on critical wear seams
- Internal PORON®2 XRD metatarsal guard
- Q-flex® non metallic penetration protection insole
- Reflective panel above the heel

Rigger's Boot

- 100% waterproof premium full grain leather
- Heavy duty, durable coated leather
- Internal PORON® XRD metatarsal guard
- Q-flex® non metallic penetration protection insole
- Pull on loops for easy donning

Lace Up Boot

- 100% waterproof CORDURA® and full grain leather
- High abrasion and chemical resistance
- New and improved SAFETYcell®
- Q-flex® non metallic penetration protection insole
- Free running, quick-adjust lacing system

CODE	STYLE	COLOURS	SIZES
FO65791	350mm Laced in Zip Mining Boot	Black	4-14, 6 ½ - 10 ½
FO65493	240mm Pull-on Riggers Boot	Brown	4-14, 6 ½ - 10 ½
FO65490	150mm Lace-up Boot	Brown	4-14, 6 ½ - 10 ½

OLIVER safety footwear conforms to AS/NZS 2210.3



ZipSider Safety Boots

- Slip, oil & fat resistant TPU/PU ToughSider sole
- OrthoTec PU footbed with anatomical arch support
- YKK zipper with ZipGuard
- AirZone Comfort System
- Padded tongue and collar
- Coats NylBond stitching
- Temperature regulating lining
- Certified to Type 1 AS/NZS 2210.3: 2009 Class 1 - 200J steel toe cap
- Rubber/PU sole (where indicated)
 - Heat, oil & acid resistant Vibram XS Work outsole
 - SRC slip resistance
 - Silicone AbrasionGuard
 - Dri-Freeze® lining that dissipates heat
- Moulded PU scuff cap for longevity (where indicated)



FV261020



FV261050



FV261060

AUSSIE BORN & BRED



FV251020



FV251050



FV451050



FV461020



FV461050



FV461060



FV561020



FV561050

CODE	STYLE	SOLE	COL.	SIZES
FV251020	Lace-up/ZipSider High Leg	TPU/PU	Black	5-14, 6½-10½
FV251050	Lace-up/ZipSider High Leg	TPU/PU	Wheat	3-14, 6½-10½
FV261020	Lace-up/ZipSider Ankle	TPU/PU	Black	3-14, 6½-10½
FV261050	Lace-up/ZipSider Ankle	TPU/PU	Wheat	3-14, 6½-10½
FV261060	Lace-up/ZipSider Ankle	TPU/PU	Stone	3-14, 6½-10½
FV451050	ZipSider High Leg Lace-up c/w Scuff Cap	TPU/PU	Wheat	5-14, 6½-10½
FV461020	ZipSider Lace-up c/w Scuff Cap	TPU/PU	Black	5-14, 6½-10½
FV461050	ZipSider Lace-up c/w Scuff Cap	TPU/PU	Wheat	5-14, 6½-10½
FV461060	ZipSider Lace-up c/w Scuff Cap	TPU/PU	Stone	5-14, 6½-10½
FV561020	High Ankle ZipSider c/w Scuff Cap	Rubber/PU	Black	5-13, 6½-10½
FV561050	High Ankle ZipSider c/w Scuff Cap	Rubber/PU	Wheat	5-13, 6½-10½



Safety Shoes

- Slip, oil & fat resistant TPU/PU ToughSider sole
- AirZone Comfort System
- Padded tongue and collar
- Coats NylBond stitching
- OrthoTec PU footbed with anatomical arch support
- Temperature regulating lining
- Certified to Type 1 AS/NZS 2210.3:2009 Class 1 - 200J steel toe cap



FV390080



FV315085



FV210025



FV315060

CODE	STYLE	SOLE	COLOUR	SIZES
FV210025	Lace-up	TPU/PU	Black	3-14, 6½-10½
FV315085	Slip-on	TPU/PU	Black	3-13, 6½-10½

CODE	STYLE	SOLE	COLOUR	SIZES
FV315060	Slip-on	TPU/PU	Stone	3-13, 6½-10½
FV390080	Lace-up Hiker	TPU/PU	Black	3-13, 6½-10½

MONGREL safety footwear conforms to AS/NZS 2210.3:2009 Class 1



Elastic Sided Safety Boots

- Slip, oil & fat resistant TPU/PU ToughSider sole
- OrthoTec PU footbed
- AirZone Comfort System
- Coats NylBond stitching
- Certified to Type 1 AS/NZS 2210.3: 2009 Class 1 - 200J steel toe cap
- Rubber/PU sole (where indicated)
 - Heat, oil & acid resistant Vibram XS Work outsole
 - SRC slip resistance
 - Temperature regulating lining
- Moulded PU scuff cap for longevity (where indicated)



CODE	STYLE	SOLE	COLOUR	SIZES
FV240020	Elastic Sided	TPU/PU	Black	5-14, 6½-10½
FV240030	Elastic Sided	TPU/PU	Claret	3-14, 6½-10½
FV240040	Elastic Sided	TPU/PU	Wheat	5-14, 6½-10½
FV240060	Elastic Sided	TPU/PU	Stone	5-14, 6½-10½

CODE	STYLE	SOLE	COLOUR	SIZES
FV240090	Oil Kip Elastic Sided	TPU/PU	Tan	5-14, 6½-10½
FV440050	Elastic Sided c/w Scuff Cap	TPU/PU	Wheat	5-14, 6½-10½
FV545030	Elastic Sided c/w Scuff Cap	Rubber/PU	Claret	5-13, 6½-10½



Lace-Up Safety Boots

- Slip, oil & fat resistant TPU/PU ToughSider sole
- OrthoTec PU footbed
- AirZone Comfort System
- Temperature regulated lining
- Padded tongue and collar
- Coats NylBond stitching
- Certified to Type 1 AS/NZS 2210.3: 2009 Class 1 - 200J steel toe cap



CODE	STYLE	SOLE	COLOUR	SIZES
FV230080	Suede Hiker	TPU/PU	Black	5-14, 6½-10½
FV260020	Ankle Lace-up	TPU/PU	Black	3-14, 6½-10½

CODE	STYLE	SOLE	COLOUR	SIZES
FV260030	Ankle Lace-up	TPU/PU	Claret	5-14, 6½-10½
FV260050	Ankle Lace-up	TPU/PU	Wheat	3-14, 6½-10½



OrthoTec PU Footbed

- Anti-bacterial polyurethane cushion footbed
- Provides arch support and shock absorption
- Incorporates AirZone comfort system



CODE	SIZES	UOM
FGX500	3, 4, 5, 6, 7, 8, 9, 10, 11, 12, 13-14	Pr



Replacement Laces

- Cotton laces to suit Mongrel footwear



CODE	LENGTH	COLOURS	UOM
FGLV120	120cm	Wheat, Black, Stone	Pr
FGLV140	140cm	Wheat, Black, Stone	Pr
FGLV150	150cm	Wheat, Stone	Pr



Suede & Nubuck Protector

- Highly effective water and oil repellent
- Promotes longer life for footwear



CODE	DESCRIPTION	UOM
FG200	200ml Atomiser Spray Bottle	Ea

MONGREL safety footwear conforms to AS/NZS 2210.3:2009 Class 1



Xfoot Rubber Safety Range

- Water resistant leathers
- Moulded TPU bump cap for added leather protection
- Dual density PU/Rubber sole - excellent slip resistance, heat resistant to 300°C
- Luxury arch PU footbed - breathable, anti-bacterial
- Broad fit steel toe cap
- XRD® Extreme Impact Protection



FBL992



FBL892



FBL897



FBL982



FBL983



FBL990



FBL997



CODE	STYLE	COLOUR	SIZES
FBL892	Women's Nubuck Zip Sided Boot	Wheat	5-11, 6½-9½
FBL897	Women's Leather Zip Sided Boot	Black	5-11, 6½-9½
FBL982	Chemical Resistant Zip Sided Boot	Black	5-14, 7½-10½
FBL983	Leather 150mm Zip Sided Boot	Crazy Horse	5-14, 7½-10½
FBL990	Leather Elastic Sided Boot	Black	3-14, 6½-10½
FBL992	Nubuck 150mm Zip Sided Boot	Wheat	5-14, 7½-10½
FBL997	Leather 150mm Zip Sided Boot	Black	5-14, 7½-10½



TPU Safety Range

- Dual density TPU sole for durability and comfort, heat resistant to 140°C
- Broad fit steel toe cap
- XRD® Extreme Impact Protection
- PU footbed - breathable and anti-bacterial



FBL318



FBL319



FBL145



FBL172



FBL143



FBL242



CODE	STYLE	COLOUR	SIZES
FBL143	Water Resistant Lace-up Boot	Crazy Horse	3-14, 7½-10½
FBL145	Suede Elastic Sided Boot	Fawn	5-13, 7½-10½
FBL172	Elastic Sided Boot	Brown	3-14, 6½-10½

CODE	STYLE	COLOUR	SIZES
FBL242	Water Resistant Zip Sided Boot	Black	5-13, 7½-10½
FBL318	Nubuck Zip Sided Boot	Wheat	3-13, 7½-10½
FBL319	Nubuck Zip Sided Boot	Black	3-13, 7½-10½



Men's Jogger Range

- Breathable upper material
- Airport friendly composite toe cap
- Durable rubber outsole with increased grip, heat resistant to 140°C
- Lightweight Comfort-XRD® Technology



FBL794



FBL793



FBL795

CODE	STYLE	COLOUR	SIZES
FBL793	Lace-up Safety Jogger	Black/White	5 - 13
FBL794	Lace-up Safety Jogger	Grey	5 - 13
FBL795	Lace-up Uniform Safety Jogger	Black	5 - 13



Women's Shoe Range

- Specific fit for women
- Airport friendly composite toe cap
- Durable rubber outsole with increased grip, heat resistant to 140°C
- Lightweight Comfort-XRD® Technology



FBL885



FBL884



FBL886

CODE	STYLE	COLOUR	SIZES
FBL884	Lace-up Safety Jogger	Black	5-11, 6½-9½
FBL885	Nubuck Zip Sided Boot	Sand/Purple	5-11, 6½-9½
FBL886	Slip-on Safety Shoe	Black	5-11, 6½-9½

BLUNDSTONE safety footwear conforms to AS/NZS 2210.3:2019



BATA INDUSTRIALS

Naturals Collection Footwear

- Cushioned dual density polyurethane outsole
- Type 1, 200 joule steel toe cap
- Oil, acid and heat resistant to 130°C
- Defined heel strike for ladder use
- Anti-static, slip resistant sole
- Premium styling featuring a wide, stable footbed
- PU cushioned insoles
- Unique Bata Tunnel System® in the heel

NATURALS



FB88841



FB60511



FB80510



FB60510



FB60514



FB80514

CODE	STYLE	COLOUR	SIZES
FB60510	Saturn Lace-up Boot	Black	2-13, 6½-10½
FB60514	Hercules Elastic Sided Boot	Black	2-13, 6½-10½
FB80510	Titan Lace-up Boot	Wheat	3-13, 6½-10½

CODE	STYLE	COLOUR	SIZES
FB80514	Mercury Elastic Sided Boot	Sand	3-13, 6½-10½
FB60511	Neptune Lace-up Shoe	Black	2-13, 6½-10½
FB88841	Zippy Nubuck Zip/Lace-up Boot	Wheat	2-13, 6½-10½



BATA INDUSTRIALS

Helix Energy Footwear Range

- High quality leather uppers with triple seam stitching
- D30® impact shock protection
- AS/NZS 2210.3 certified
- Dual density PU/Rubber sole - heat resistant to 300°C
- BOA lacing system and rubber soles (selected styles)
- Tri density PU/foam comfort insole
- Type 1 200 joule steel toe cap
*Longreach CT styles include Type 1 200 joule composite toe cap

HELIX
ENERGY FOOTWEAR



FB83964



FB63979



FB83968



FB65143



FB63963



FB44987



FB85139

CODE	STYLE	COLOUR	SIZES
FB83964	Horizon Leather Zip Side/Lace-up Boot	Wheat Nubuck	3-14, 6½-10½
FB63963	Horizon Leather Zip Side/Lace-up Boot	Black Full Grain	3-14, 6½-10½
FB83968	Longreach Leather Lace-up Boot	Wheat Nubuck	3-14, 6½-10½
FB63979	Longreach Leather Lace-up Boot	Black Full Grain	3-14, 6½-10½
FB86147	Longreach-CT Zip Side/Lace-up Boot*	Wheat Nubuck	3-14, 6½-10½
FB66146	Longreach-CT Zip Side/Lace-up Boot*	Black Full Grain	3-14, 6½-10½
FB44987	Trekker-ST Elastic Sided Boot	Claret Full Grain	3-14, 7½-10½
FB85139	Ranger BOA Lace Boot (Rubber Sole)	Wheat Nubuck	3-14, 6½-10½
FB65143	Ranger BOA Lace Boot (Rubber Sole)	Black Full Grain	3-14, 6½-10½



BATA INDUSTRIALS

Deep Comfort Footwear Range

- Dual density PU/rubber sole
- Lamella & CTS absorption zones
- Steel safety toe cap
- External scuff cap



FB80647



FB60647



CODE	STYLE	COLOUR	SIZES
FB80647	Patriot Nubuck Zip Side/Lace-up Boot	Wheat	5-14, 6½-10½
FB60647	Patriot Leather Zip Side/Lace-up Boot	Black	4-14, 6½-10½



BATA INDUSTRIALS

SportMates Footwear Range

- Dual density EVA/rubber sole - heat, oil and acid resistant
- Padded collar and tongue
- Contemporary sports styling and lightweight design
- Breathable suede leather and mesh uppers
- Type 1 (200 joule steel toe cap)



FB62687



FB66686

CODE	STYLE	COLOUR	SIZES
FB62687	Fury Suede Safety Jogger	Black	3-13
FB66686	Force KPU/Mesh Hiker	Black	3-13

BATA INDUSTRIALS safety footwear conforms to AS/NZS 2210.3



BATA INDUSTRIALS

Utility PVC Gumboots

- Fully lined, 400mm knee length boots
- Oil & acid resistant
- Kick-off lug
- Reinforced at heel, ankle and shin
- AS/NZS 2210.3:2009 (safety styles)



FBG65190

FBG11090

FBG66380

FBG69092



CODE	STYLE	COLOUR	SIZES
FBG69092	Steel Toe/Midssole Boot	Black/Blue	5-12
FBG66380	Non Safety Boot	Black	5-12
FBG11090	Steel Toe Boot	White	5-12
FBG65190	Steel Toe Boot	Black/Red	5-12



BATA INDUSTRIALS

Jobmaster III PVC Gumboots

- 400mm knee length boots
- Reinforced at heel, toe, calf and ankle
- Comfort fabric lining
- Wide comfortable fitting with broad toe design
- Kick-off lug
- AS/NZS 2210.3:2009 (safety styles)



FBG62290

FBG67280

FBG22292



CODE	STYLE	COLOUR	SIZES
FBG22292	Steel Toe/Midssole Boot	Black/Grey	4-14
FBG67280	Non Safety Boot	Black/Green	4-14
FBG62290	Steel Toe Boot	Black/Grey	4-14



10 Series PVC Gumboots

- PVC/Nitrile sole
- Nylon lined
- 3 trim heights
- Heavy duty PVC upper
- Reinforced ankle, heel and instep
- Wide profile Type 1 toe cap
- AS/NZS 2210.3:2009



FKG10105

FKG10110

FKG10100

CODE	STYLE	COLOUR	SIZES
FKG10100	Steel Toe Boot	Black/Yellow	5-12
FKG10110	Steel Toe Boot	White/Tan	5-12
FKG10105	Steel Toe/Midssole Boot	Black/Yellow	5-12



22 Series PVC Gumboot

- Green, waterproof PVC/nitrile gumboot
- Steelflex steel midsole penetration protection
- METprotect metatarsal protection
- Kick-off spur
- Two trim heights
- AS/NZS 2210.3:2009



COMFORTcushion Impact Absorption System



NATUREform Type 1 Toe Cap



CODE	STYLE	COLOUR	SIZES
FOG22205	PVC Gumboot Safety Toe & Midssole	Green/Tan	5-13



Bamboo Charcoal Work Socks

- Nano Bamboo Charcoal Technology in sole helps keep feet dry and comfortable
- Ultimate anti-bacterial performance which eliminates foot odour
- Regulates skin temperature keeping your skin cooler in summer and warmer in winter
- Ribbed band on foot for less movement

Thick Work Sock

- 4 yarn sock

Work Sock

- Thinner, 3 yarn sock

Trekking Sock



FGS30



FGS31/2



FGS33

CODE	DESCRIPTION	COLOURS	SIZES	UOM
FGS30	Bamboo Charcoal Thick Work Sock - 4 Yarn	Various	4-6, 6-10, 10-14	Pair
FGS31/2	Bamboo Charcoal Work Sock - 3 Yarn	Navy, Black	6-10, 10-14	Pack/2 Pairs
FGS33	Bamboo Charcoal Trekking Sock	Brown, Red, Khaki, Black	4-6, 6-10, 10-14	Pair



Bamboo Work Socks

- Highly absorbent, wear resistant fabric - 92% bamboo/8% elastane
- Antibacterial properties to reduce foot odour
- Thermo-regulating for hot or cold weather
- Extensive colour palette
- XLong style - perfect for gumboots



FGS08

FGS09



CODE	DESCRIPTION	COLOURS	SIZES	UOM
FGS08	Bamboo Sock Extra Thick Short	Various	6 - 10 10 - 14	Pair
FGS09	Bamboo XL Gumboot Sock	Black, Navy, Khaki	14 - 18	Pair



Dubbin Polish

- Traditional non-shine waterproofing compound
- Not recommended for suede or nubuck



CODE	DESCRIPTION	COLOURS	UOM
FG3301	Dubbin 125gm	Black, Brown, Tan, Neutral	Ea



Waterproofer Spray

- Protection for leather, suede and nubuck
- Ozone friendly aerosol



CODE	DESCRIPTION	UOM
FG43400	Waterproofer 200gm	Ea



Boot Cleaning Brush

- Excellent for building and construction sites
- Sturdy construction for long life
- UV stabilised bristles
- Can be bolted down



CODE	DESCRIPTION	UOM
FGBB4059	Badger Boot Cleaning Brush	Ea



Bowyangs - Bootcovers

- Elastic top to cover top of wearer's boots
- Keeps the dirt out of your boots
- Made of cotton drill
- One size



CODE	DESCRIPTION	COLOURS	UOM
FG15C	Bootcover Cotton	Navy, Khaki, Green	Pair
FG15HV	Bootcover HI VIS	Orange	Pair



Boot Dip Mat

- Raised walls to hold detergent or any liquid for hygienic cleaning
- Hundreds of cleaning bristles encourage boot cleaning whilst trapping dirt
- Yellow edges for high visibility
- Cross grip rear design firmly holds the mat to the floor



CODE	DESCRIPTION	UOM
YMATBDM	Boot Dip Mat 980mm x 810mm x 47mm	Ea

HAND PROTECTION

APPLICATION

Many workplace tasks cannot be undertaken safely without some form of hand protection. In general, hand protection must be provided wherever there is residual hand injury risk after other control measures have been put in place.

RISK ASSESSMENT

The need for hand protection should be assessed by conducting an audit of potential workplace hazards. To ensure that the most appropriate glove is provided for the tasks and the environmental conditions, it is necessary to:

- identify the hazard(s) and the need for hand protection;
- identify the level of manual dexterity required;
- select suitable material to give the protection required;
- select a suitable style and a good fit;
- determine whether re-useable or disposable gloves are appropriate.

CHEMICAL RISKS

AS/NZS 2161.10.3:2005 and EN374.1:2016 apply to gloves that protect against chemicals and micro-organisms. The pictograms below signify that gloves so marked indicate:



TYPE 'C'
X - LOW CHEMICAL
Level 1 (>10mins) performance against at least 1 chemical



TYPE 'B'
X X X
Level 2 (>30mins) performance against at least 3 chemicals



TYPE 'A'
X X X X X X
Level 2 (>30mins) performance against at least 6 chemicals

A	METHANOL	J	N-HEPTANE
B	ACETONE	K	SODIUM HYDROXIDE 40%
C	ACETONITRILE	L	SULPHURIC ACID 96%
D	DICHLOROMETHANE	M	NITRIC ACID 65%
E	CARBON DISULPHIDE	N	ACETIC ACID 99%
F	TOLUENE	O	AMMONIA HYDROXIDE 25%
G	DIETHYLAMINE	P	HYDROGEN PEROXIDE 30%
H	TETRAHYDROFURANE	S	HYDROFLUORIC ACID 40%
I	ETHYL ACETATE	T	FORMALDEHYDE 37%

When dealing with glove performance against chemicals it is important to reference supplier glove compatibility charts for suitability and permeation & degradation time frames.

USEFUL REFERENCES

AS/NZS 2161 Set: 2008 Occupational Protective Gloves Set.

EN 388



XXXXXX

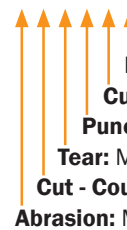

MECHANICAL RISKS

AS/NZS 2161.3/EN388 applies to gloves that protect against physical and mechanical hazards. Glove performance is indicated by the numbers below the pictogram for Abrasion, Cut-Coup, Tear, Puncture, Cut ISO13997 and Impact EN13594:2015.

Impact EN13594:2015: Pass or Fail

Cut ISO13997: Min A, Max F

Puncture: Min 0, Max 4

Tear: Min 0, Max 4

Cut - Coup: Min 0, Max 5

Abrasion: Min 0, Max 4

SAFETY TIPS

- Correct glove fit is essential to comfort and dexterity.
- Do not use gloves worn by others or where there is any uncertainty about prior chemical exposure.
- Consider the use of barrier creams before and after work - but never as the primary care.
- Cotton liners may assist in reducing moisture where prolonged use occurs.
- Extended cuff length may provide protection to the lower arm.
- Dispose of contaminated gloves appropriately.

All workers should be trained in the correct use and maintenance of personal protective equipment.

CUT RESISTANT	77
SYNTHETIC/MECHANICS	80
RIGGERS/LEATHER GENERAL PURPOSE	81
NITRILE DIP	82
LATEX DIP	83
PU, PVC DIP/INDUSTRIAL	84
CHEMICAL, CLEANING	85
DISPOSABLE	86
WELDER'S/COTTON/ELECTRICIAN'S	87
ACCESSORIES	88

Cut Resistant Gloves



PRO
PRO CHOICE SAFETY GEAR

Arax
The Cutting Edge in Hand Protection

- High performance industrial yarn with a proprietary Arax® Knit Technology
- Superior cut resistance is in the way the proprietary Arax® fabric is woven
- Tight knit for greater protection
- Anti-static and breathable fabric
- Tested to EN388:2016 - CUT ISO13997 'real world' cut test

ARAX® Platinum - Nitrile Cut Level F

- Durable black nitrile sand finish coated palm
- High level of cut resistance without sacrificing comfort or dexterity
- EN388 4X44F



CODE	SIZES	UOM
GCRAPNPD	7 - 11	Pair



ARAX® Gold Cut - Nitrile Cut Level D

- Gold ARAX® knit liner
- Black nitrile sand dip
- Contact heat resistant to 100°C
- EN388 4X43D

CODE	SIZES	UOM
GCRAFYN	7 - 11	Pair



ARAX® Wet Grip - Nitrile Cut Level D

- Black nitrile sand palm dip for superior grip in wet/greasy conditions
- Contact heat resistant to 100°C
- EN388 4X42D

CODE	SIZES	UOM
GCRAND	7 - 11	Pair



ARAX® Gold PU Dip - Cut Level D

- HI VIS polyurethane palm dip
- Lightweight Arax® liner
- Excellent dexterity - Bare Hand Technology (BHT)
- EN388 4X43D

CODE	SIZES	UOM
GCRAFYPU	7 - 11	Pair



ARAX® Heavy Duty - Nitrile Cut Level D

- Reinforced chrome leather palm
- Black nitrile foam palm dip
- Contact heat resistant to 100°C
- EN388 4X44D

CODE	SIZES	UOM
GCRAFND	7 - 11	Pair



ARAX® Touch - PU Cut Level C

- Water-based black polyurethane palm dip for superior sensitivity and dexterity
- Contact heat resistant to 100°C
- EN388 4X42C

CODE	SIZES	UOM
GCRAPUD	7 - 11	Pair



ARAX® Liner - Cut Level D

- Uncoated liner glove
- Contact heat resistant to 100°C
- EN388 4X4XD

CODE	SIZES	UOM
GCRAL	7 - 11	Pair



ARAX® One® Anti Vibe - Cut Level D

- TPR padding protects fingers and knuckles
- Anti-vibration foam padded palm
- Black nitrile sand palm dip for superior grip in wet/greasy conditions
- EN388 4X43D

CODE	SIZES	UOM
GCRONE	7 - 11	Pair



ARAX® Wet Grip Extendor - Nitrile Cut Level D

- Black nitrile sand palm dip for superior grip in wet/greasy conditions
- Extended cuff protects forearm
- Contact heat resistant to 100°C
- EN388 4X42D

CODE	SIZES	UOM
GCRANEC	7 - 11	Pair



ARAX® Lite - Nitrile Cut Level C

- Lite ARAX® knit liner
- Super thin 18 gauge machine knit
- Black nitrile sand dip
- EN388 4X13C

CODE	SIZES	UOM
GCRAGND	7 - 11	Pair



ARAX® Dry Grip - Latex Cut Level C

- Black latex crinkle palm dip
- Superior grip on smooth dry surfaces
- Contact heat resistant to 100°C
- EN388 4X42C

CODE	SIZES	UOM
GCRALD	7 - 11	Pair

Cut Resistant Gloves



Honeywell Spectra

- Super-fibre engineered for its lightweight strength, superior cut resistance and abrasion resistance
- Enhanced dexterity and durability
- Natural cooling and moisture-repelling properties
- Made from a knit of Spectra polyamide, composite fibre & elastane



SpectraKnight® PU Cut 5

- Polyurethane palm dip coating provides outstanding abrasion resistance
- Ventilated back for breathability
- Spectra touch gives an added sensation of cool comfort
- 13 gauge knitting technique
- EN388 4543

CODE	SIZES	UOM
GCRSPEC5	7 - 11	Pair

ELLIOTTS



G-Flex Dynamax® C5 Roustabout Impact Cut 5

- K-Guard® TPR exoskeleton top of hand impact protection
- Dynamax® C5 13 gauge seamless liner
- T-Touch coating over a blue nitrile ¾ coating
- Excellent dexterity, sensitivity and tactility
- EN388 4543 C



CODE	SIZES	UOM
GCR3416	8 - 11	Pair

G-Flex Dynamax® C5 AirTouch Nitrile Cut 5

- Lightweight AIRTouch nitrile palm dip coating
- Dynamax® C5 15 gauge seamless blue liner
- Abrasion and tear resistance with back of hand ventilation
- Excellent dexterity, sensitivity & tactility
- EN388 4543 C



CODE	SIZES	UOM
GCR3420	7 - 11	Pair

Perfect Cutting® Spectra NBR Cut 3

- Nitrile palm dip coating for secure grip on smooth and rough surfaces
- Outstanding abrasion resistance
- Superior fit, dexterity and durability
- Seamless knit with open back for ventilation
- EN388 4343



CODE	SIZES	UOM
GCR2318766	7 - 11	Pair

Perfect Cutting® Spectra PU Cut 3

- Polyurethane palm dip coating
- Resistant to abrasion and snags/tears
- Superior fit, dexterity and durability
- Seamless knit with open back for ventilation
- EN388 4342



CODE	SIZES	UOM
GCR2318765	7 - 11	Pair

Needle & Puncture Resistant Gloves



Protection in high injury applications like recycling, waste handling and bottling.



CP Neon Wrap

- Suitable for hypodermic needles, broken glass, sharp metal edges, or other sharps
- CP material on palms, fingers and fingertips
- String knit PU coated - excellent durability and grip when handling wet and oily surfaces
- Back of hand breathability
- ASTM F3 2878-10 Hypodermic needle puncture 25 gauge >0.75 lbf

CODE	LENGTH	SIZES	UOM
GRCRPR330	330mm	S - XL	Pair
GRCRPR430	430mm	S - XL	Pair



Alpha Glove

- Hypodermic needle and cut-resistant palm and fingertips
- Slash-resistant knit on back of hand
- Outstanding dexterity with short break-in time
- High-stretch knit backing for snug fit
- Grip pads to assist in searches
- ASTM F3 2878-10 Hypodermic needle puncture 25 gauge <1.25lbf

CODE	SIZES	UOM
GCR2US008	XS - 2XL	Pair



Bravo Glove

- Super lightweight aramid fabric construction
- Needle resistant palm and fingertips
- Breathable mesh knit - ideal for use in warm weather
- Excellent dexterity and comfort
- ASTM F3 2878-10 Hypodermic needle puncture 25 gauge >1.0 lbf

CODE	SIZES	UOM
GCR2US009	XS - 2XL	Pair



Delta Glove

- Hypodermic needle and cut resistant palm and fingertips
- Slash-resistant knit on inside back of hand
- Outstanding dexterity with short break-in time
- 100% leather shell gives glove snug fit with tactile sensitivity
- ASTM F3 2878-10 Hypodermic needle puncture 25 gauge <1.25 lbf

CODE	SIZES	UOM
GCR2US010	S - XL	Pair

Synthetic Leather Gloves



PRO
PRO CHOICE SAFETY GEAR

PROFIT Mechanics

- Quality synthetic leather fabrics
- Wide range of coatings for improved wear and performance
- Breathability through design and fabric selection
- Abrasion resistant
- Full hand, fingerless, anti-vibration and thermal styles

ProFit® Riggamate

- Synthetic leather palm
- Reinforced foam padded inner palm
- Neoprene knuckle panel
- Velcro strap
- EN388 3121



CODE	COLOUR	SIZES	UOM
GLSPFR	Black	S - 2XL	Pair
GLSPFRY	Yellow	S - 2XL	Pair



ProFit® Stockman

- Premium cow grain leather palm
- Foam padded palm
- Split leather fingertips
- Soft TPR impact knuckle protectors
- EN388 3133



ProFit® Deer Hunter

- Premium gold deer grain leather palm
- Nylon, lycra, foam back for comfort & flexibility
- Neoprene knuckle bar protectors
- Elastic cuff with fastener tape
- EN388 3121



ProFit® Razorback

- Hand impact protection system - thermoplastic rubber on back of fingers, knuckle & hand
- Double layer water/oil resistant palm
- Silicone grip
- Elastic cuff
- EN388 3233



ProFit® Silver Riggamate

- Lightweight and durable synthetic leather palm
- Breathable mesh back to reduce hand heat
- Keystone thumb pattern
- EN388 3111



ProFit® PROtec

- Durable synthetic leather palm
- Reinforced foam padded palm
- Neoprene knuckle bar
- Mesh backing for breathability
- Extended neoprene cuff
- EN388 3121

CODE	SIZES	UOM
GLSPS	S - 2XL	Pair

CODE	SIZES	UOM
GLSPFD	S - 2XL	Pair

CODE	SIZES	UOM
GLSPFRB	S - 4XL	Pair

CODE	SIZES	UOM
GLSPFRS	S - 2XL	Pair

CODE	SIZES	UOM
GLSPT	S - 3XL	Pair



ProFit® PROVibe

- Anti-vibration 100% foam padded palm
- Padded knuckle panel
- Easy pull on tab
- Velcro® strap for snug fit
- Ideal grip for hand/power tools
- EN388 4121



ProFit® Fingerless (AV)

- Synthetic leather Gecko grip palm
- SBR foam insert for vibration attenuation
- Reinforced foam padded inner palm
- Breathable mesh back
- Padded knuckles
- EN388 3131



ProFit® Magnetic

- Synthetic leather Gecko grip palm
- Cut off fingers
- Magnet inserted back of hand
- Neoprene knuckle panel
- Easy-on finger loop
- EN388 3131



DexiPro One Impact

- Ultra fine nitrile foam coating provides dexterity
- Full back of hand protection to assist with impact injuries
- Reinforced thumb crutch
- Velcro wrist closure
- EN388 4221XP



ProFit® PROtec HI VIS

- Durable synthetic leather palm
- Reinforced foam padded palm
- Neoprene knuckle bar
- HI VIS mesh backing for breathability
- Extended neoprene cuff
- EN388 3121

CODE	SIZES	UOM
GAVPV	M - 2XL	Pair

CODE	SIZES	UOM
GLSPF	S - 2XL	Pair

CODE	SIZES	UOM
GLSPFM	S - 2XL	Pair

CODE	SIZES	UOM
GRNONNFY	7 - 11	Pair

CODE	SIZES	UOM
GLSPTY	S - 2XL	Pair

Synthetic Leather Gloves



ELLIOTTS Mec-Flex Mechanics

Mec-Flex® Oiler LX

- Full 360° Dynamax Cut level 5 protection on the palm, back of hand and all finger walls
- K-Guard® TPR back of hand exoskeleton
- Soft, durable goat leather on the palm
- Neoprene cuff
- Kevlar® stitched palm
- HI VIS stretch spandex on the back of the hand
- EN388 2542DP



CODE	SIZES	UOM
GLS6230	M - 2XL	Pair

Mec-Flex® Rigger GT

- Rigger style with goat skin palm
- K-Guard® TPR back of hand exoskeleton
- Rubberised reinforced palm
- Black soft neoprene cuff with TPR pull tab and Velcro® closure
- EN388 3133



CODE	SIZES	UOM
GLS6310	M - 2XL	Pair

Leather Riggers Gloves



Riggamate® Cowsplit

- Grey 'suede look' cow split leather
- Tough and durable
- Elastic on back of wrist
- EN388 3121

CODE	SIZES	UOM
GLC050	L - 2XL	Pair



Riggamate® Natural

- High quality cow grain leather
- Wing thumb design
- Elastic on back of wrist
- EN388 3121

CODE	SIZES	UOM
GLC301	S - 3XL	Pair



Riggamate® Premium

- Premium beige cow grain leather
- Wing thumb design
- Elastic on back of wrist
- EN388 3121

CODE	SIZES	UOM
GLC201	S - 2XL	Pair



Riggamate® Cut Resistant

- High quality cow grain leather
- Knitted Kevlar® palm
- Wing thumb
- Stitch free palm
- EN388 3522

CODE	SIZES	UOM
GCR301	M - 2XL	Pair

General Purpose Leather Gloves



Yellow & Grey

- Heavy duty one piece palm
- Yellow safety cuff & knuckle bar
- Cotton back with elastic
- EN388 3232

CODE	SIZES	UOM
GLC727	One Size	Pair



Grey All Chrome

- 'A' Grade quality heavy duty
- All chrome cow split leather
- 5cm leather cuff
- EN388 3232

CODE	SIZES	UOM
GLC722	One Size	Pair



Candy Stripe

- Lightweight cow split leather palm
- Cotton back
- Elastic on back of wrist
- Safety cuff & knuckle bar

CODE	SIZES	UOM
GLC747	One Size	Pair



Green & Grey

- Heavy duty with safety cuff
- Reinforced palm/thumb/fingers
- Cotton back with knuckle bar
- EN388 3232

CODE	SIZES	UOM
GLC714	One Size	Pair

PALM SHOWN

General Purpose Nitrile Dipped Gloves



PRO PROsense Nitrile



ONE - Multi Purpose

- Foam nitrile palm
- HI VIS
- Seamless glove liner
- TPR padded knuckles/fingers
- EN388 4241

CODE	SIZES	UOM
GRNONN	7 - 11	Pair



DexiPro™ Wet/Dry

- Nitrile coating for wet/dry grip
- Lycra infused lint free nylon knit liner
- Extra long 20mm cuff
- Anti-static
- EN388 3221

CODE	SIZES	UOM
GRNBNNL	7 - 11	Pair

MaxiPro™ Wet/Dry PU Foam

- Palm dipped nitrile/water based PU foam coating
- Seamless 15 gauge, nylon fused lycra shell
- Back of hand dip options for additional protection
- Wet & dry grip without sacrificing dexterity
- Can be used with touch screens
- EN388 4112



GRNNPN

CODE	DESCRIPTION	SIZES	UOM
GRNNPN	MaxiPro Palm Dip	6 - 11	Pair
GRNNPNHB	MaxiPro 270 ¾ Dip	6 - 11	Pair
GRNNPNFB	MaxiPro 360 Full Dip	6 - 11	Pair



Touch Screen Sand Winter Lined

- Full 360° nitrile dip
- Sandy nitrile dip with touchscreen capabilities
- Warm acrylic liner
- EN388 3121

CODE	SIZES	UOM
GRNNSDWL	7 - 12	Pair



Lite Grip Water Repellent

- Ultra thin nitrile foam
- Full hand dip on nylon knit liner
- Water/oil repellent
- Wet/dry grip
- EN388 4121

CODE	SIZES	UOM
GRNNFWR	7 - 11	Pair



DexiPro ONE Impact

- Ultra-fine nitrile foam coating for dexterity
- Full back of hand protection
- Reinforced thumb crutch
- Velcro wrist closure
- EN388 4221XP

CODE	SIZES	UOM
GRNONNFY	7 - 11	Pair



DexiFrost Winter Liner

- Nylon/lycra with brushed acrylic liner
- Nitrile dot palm
- Wet/dry grip
- Breathable foam technology
- EN388 4131

CODE	SIZES	UOM
GRNBNNLF	7 - 11	Pair



Lite Grip Nitrile Foam

- Nitrile foam palm dip
- Breathable and lightweight nylon liner
- Anti-static
- EN388 4131

CODE	SIZES	UOM
GRN5643	7 - 11	Pair

General Purpose Nitrile Dipped Gloves



PRO PROsense SuperGuard/SuperLite



SuperGuard Safety Cuff

- Heavyweight abrasion resistant nitrile
- Fully dipped
- Cotton liner
- Canvas cuff
- EN388 4121

CODE	SIZES	UOM
GRN5630	9 - 11	Pair



SuperGuard Blue

- Heavyweight abrasion resistant nitrile
- ¾ dipped
- Cotton liner
- Knit wrist cuff
- EN388 4121

CODE	SIZES	UOM
GRN5635	9 - 10	Pair



SuperLite Blue Full Dip

- Lightweight fully dipped nitrile
- Abrasion resistant
- Cotton liner
- Knit wrist
- EN388 4111

CODE	SIZES	UOM
GRNBRFBB	9 - 10	Pair



SuperLite

- Lightweight ¾ dipped nitrile
- Abrasion resistant
- Cotton liner
- Knit wrist
- EN388 4111

CODE	COL.	SIZES	UOM
GRN5460	Orange	7 - 10	Pair
GRNBRB	Blue	7 - 10	Pair

General Purpose Nitrile Dipped Gloves



Honeywell WorkEasy® Nitrile

WorkEasy® Polytril Plus

- Sandy nitrile palm dip
- Resists oil/grease
- Black nylon seamless knit construction
- Knit wrist
- Black and HI VIS options
- EN388 4121



CODE	COLOUR	SIZES	UOM
GRN2232232	Black	7 - 11	Pair
GRN2232232H	HI VIS	7 - 11	Pair

ELLIOTTS E



G-Flex SandStorm

- Lightweight "sandy" foam nitrile coating
- Black nylon 18 gauge seamless liner
- Palm dip
- Open back of hand
- Light oil surface grip
- EN388 4121



CODE	SIZES	UOM
GRN3223	7 - 11	Pair

G-Flex Nitrile

- Super lightweight nitrile coating
- Seamless 18 gauge black nylon liner
- Palm dip - open back of hand
- Wet/dry grip
- EN388 4141



CODE	SIZES	UOM
GRN3000	7 - 11	Pair

WorkEasy® 110

- Nitrile palm dip
- Resists oil/grease
- Lightweight black polyester shell
- Smooth/rough surface grip
- EN388 4121



WorkEasy® Grip

- Sandy nitrile full dip
- Resists oil/grease
- Black nylon seamless knit construction
- EN388 4121



CODE	SIZES	UOM
GRN2232232F	7 - 11	Pair

General Purpose Latex Dipped Gloves



Latex

ProSense™ Black Panther®

- Latex dipped palm for extra grip
- Seamless 13 gauge black nylon liner
- Excellent abrasion resistance
- Breathable anti-static liner
- EN388 3121



CODE	SIZES	UOM
GRL5000	7 - 11	Pair

ELLIOTTS E



G-Flex Red Devil™

- Lightweight crinkle latex dip palm for excellent grip on light oil surfaces
- Seamless nylon liner
- Protection from small knicks and cuts
- EN388 2242



CODE	SIZES	UOM
GRL3220	8 - 11	Pair

ProSense™ Latex Foam

- Latex foam coated palm
- Anti-static HI VIS nylon liner
- Anti-microbial
- Wet/dry grip
- EN388 3131



ProSense™ Diamond Grip

- Crinkle latex dip palm
- Poly/cotton liner
- Open knit back
- EN388 3141



ProSense™ ArcticPro

- Latex dip palm
- HI VIS poly/cotton knit
- Acrylic wool lined
- EN388 1141



Latex Glass Gripper

- Latex ¾ dip
- Ripple palm for grip
- Jersey lined for comfort and sweat absorption
- Knit wrist



CODE	SIZES	UOM
GRLFN	7 - 11	Pair

CODE	SIZES	UOM
GRL5485	8 - 11	Pair

CODE	SIZES	UOM
GRLAB	9 - 11	Pair

CODE	SIZES	UOM
GRL5476	One Size	Pair

General PU/PVC Dipped Gloves



PU/PVC

ProSense™ Stinga®

- PVC foam palm dip
- Seamless 15 gauge nylon shell
- Water repellent
- Wet/dry grip
- Silicone free
- EN388 4131



CODE	SIZES	UOM
GPVNPF	7 - 11	Pair

Honeywell

WorkEasy®

WorkEasy® 210

- PU palm dip
- Lightweight 13 gauge nylon liner
- Cool, comfortable, flexible
- EN388 4121



CODE	SIZES	UOM
GPUWE210	L - 2XL	Pair

WorkEasy® Lite

- Ultra thin PU palm dip
- Lightweight 18 gauge nylon liner
- Form fitting for tactile sensitivity
- EN388 2121



CODE	SIZES	UOM
GPUWE50	S - XL	Pair

ELLIOTTS



G-Flex® Lite

- Ultra-lightweight PU palm coat
- Seamless, lint free nylon liner
- Excellent dexterity, sensitivity & tactility
- EN388 4142



CODE	SIZES	UOM
GPU3100	7 - 11	Pair



ProSense™ ProLite®

- PU palm dip
- Breathable nylon liner
- Anti-static
- EN388 4131



ProSense™ ProLite® HI VIS

- HI VIS PU palm dip
- Breathable nylon liner
- Anti-static
- EN388 4131



ProSense™ Stinga Frost

- PVC foam palm dip
- Seamless 15 gauge nylon shell
- Fleece lined
- Water repellent
- Wet/dry grip
- EN388 3221

CODE	SIZES	UOM
GPUPUN	7 - 11	Pair

CODE	SIZES	UOM
GPUPUNY	6 - 11	Pair

CODE	SIZES	UOM
GPVNPF	7 - 11	Pair

Industrial PVC Gloves



Single Dip PVC

- Oil & grease resistant
- Interlock lined
- Abrasion resistant
- EN388 3121



GPV127



GPV126



GPV145

CODE	DESCRIPTION	SIZES	UOM
GPV127	27cm	One Size	Pair
GPV126	27cm Knit Wrist	One Size	Pair
GPV145	45cm	One Size	Pair

Double Dip PVC

- Sand palm finish
- Oil & grease resistant
- Jersey lined
- Abrasion resistant
- EN388 4221



GPV227



GPV245

CODE	LENGTH	SIZES	UOM
GPV227	27cm	One Size	Pair
GPV245	45cm	One Size	Pair

Chemical Gloves



Double Dipped PVC

- Double dipped PVC
- Chemical Cat III gloves
- Resistant to chemicals, oil and grease
- Sandy palm finish for enhanced grip
- Jersey lined for extra comfort
- Available in 3 lengths
- EN374-1 JKL
- EN388 4121



CODE	LENGTH	SIZES	UOM
GPV827	27cm	XL	Pair
GPV835	35cm	XL	Pair
GPV845	45cm	XL	Pair

ELLIOTTS

ChemVex® Nitrile

ChemVex® 7000

- Triple layer nitrile
- T-Touch palm
- Resistant to chemicals, oil and grease
- Superior grip in wet and oily conditions
- 18 gauge nylon liner
- 356mm length with safety cuff
- EN374-3 AJKL
- EN388 4121



CODE	SIZES	UOM
GRN7000	7 - 11	Pair

Chemical Gloves



Neoprene & Nitrile

Neoprene Chemical

- Heavy duty neoprene
- Cotton flock lining
- Resistant to solvents, oils & mild acids
- EN388 4110/
- EN374-3 ABCIJ



Nitrile Chemical

- Premium grade nitrile
- Textured palm
- Flock lined
- EN374-1 AJKLPS or AJKLPT
- EN388 4101



CODE	LENGTH	SIZES	UOM
GRN4000	33cm	L - 2XL	Pair

CODE	LENGTH	SIZES	UOM
GRN5650	33cm	S - 3XL	Pair
GRN5655	45cm	M - XL	Pair

ELLIOTTS

ChemVex® Nitrile

ChemVex® C3 7010

- 18 gauge Dynamax cut level 3 liner
- Triple layer nitrile
- T-Touch palm
- Resistant to chemicals, oil and grease
- 356mm length with safety cuff
- EN374-3 AJKL
- EN388 4343



CODE	SIZES	UOM
GRN7010	8 - 11	Pair

Cleaning Gloves



Latex Rubber

Thrifty Yellows

- Yellow latex rubber
- Non slip embossed palm
- Lightweight, soft and flexible
- Flock lined comfort
- 30cm length - 0.38mm thick
- HACCP certification



Tuff Pinks

- Pink latex rubber
- Honeycomb palm grip
- Silver lined - anti-microbial protection to resist bacteria
- Resistant to detergents and diluted chemicals
- 30cm length - 0.50mm thick
- HACCP certification



Process Blues

- Food safe blue latex rubber
- Honeycomb palm grip
- Blue lined - anti-microbial protection to resist bacteria
- Resistant to detergents and diluted chemicals
- 30cm length - 0.45mm thick
- HACCP certification



CODE	SIZES	UOM
GRL350	S - XL	Pair

CODE	SIZES	UOM
GRL330	7 - 7½, 8 - 8½, 9 - 9½, 10 - 10½	Pair

CODE	SIZES	UOM
GRL300	7 - 7½, 8 - 8½, 9 - 9½, 10 - 10½	Pair

Disposable Gloves - Latex



Securitex

Securitex Examination

- Latex rubber
- Beaded cuff
- Ambidextrous design
- 295mm length
- Textured surface
- For single use, non sterile
- TGA listed
- HACCP Certification



CODE	DESCR.	SIZES	UOM
GDL6500	Lightly Powdered	S - XL	Bx/100
GDL6510	Powder Free	XS - XL	

Securitex HR Examination PF

- High Risk examination glove
- Triple thickness latex
- Powder free
- Textured surface
- Ambidextrous design - 295mm
- For single use, non sterile
- TGA listed
- HACCP Certification



CODE	SIZES	UOM
GDL41066	S - 2XL	Bx/50



Latex

Examination

- Latex rubber
- Textured surface
- Ambidextrous design
- 'Sensitive touch' for enhanced dexterity
- For single use, non sterile
- HACCP Certification



CODE	DESCR.	SIZES	UOM
GDL6550	Lightly Powdered	S - XL	Bx/100
GDL6560	Powder Free	XS - XL	

Disposable Gloves - Vinyl



General Purpose Vinyl LP

- Vinyl - latex free
- Lightly powdered
- Ambidextrous design
- Smooth surface
- For single use, non sterile
- HACCP Certification



CODE	COLOURS	SIZES	UOM
GDV5525	Clear, Blue	S - XL	Bx/100

General Purpose Vinyl PF

- Vinyl - latex free
- Powder free
- Smooth surface
- Ambidextrous design
- For single use, non sterile
- HACCP Certification



CODE	COLOURS	SIZES	UOM
GDV5520	Clear, Blue	S - XL	Bx/100



All Clear/ Foodie Blues Vinyl LP

- Vinyl - latex free
- Lightly powdered
- Ambidextrous design
- Oil/fat/grease resistant
- HACCP Certification



CODE	DESCR.	SIZES	UOM
GDV5500	Foodie Blue	S - XL	Bx/100
GDV5505	All Clear	S - XL	Bx/100

Disposable Gloves - Nitrile



Nitrile Blax PF

- Strong, durable nitrile
- Powder free
- Resistant to chemicals, oils & fuels
- Textured fingertips
- Ambidextrous design
- Beaded cuff



CODE	SIZES	UOM
GDN41079	S - XL	Bx/100



Nitesafe Examination PF

- Strong, stretchy nitrile
- Powder free
- Resistant to chemicals
- Textured surface
- Ambidextrous design
- Single use - non sterile
- TGA listed
- HACCP Certification

CODE	SIZES	UOM
GDN7500	S - XL	Bx/100



General Purpose Nitrile PF

- Industrial grade nitrile
- Powder free
- Chemical & oil resistant
- Textured surface
- Single use - non sterile
- Bio-degradable option
- HACCP Certification



CODE	COL.	SIZES	UOM
GDN7550	Blue	S - XL	Bx/100
GDN2000	Black	S - 2XL	



GDN1500

GDN1000

Extra Heavy Duty Nitrile

- Stronger, thicker nitrile
- Powder free
- Chemical, oil, grease, fuels, cleaners and solvent resistant
- Textured surface
- HACCP Certification



CODE	COL.	SZ.	UOM
GDN1000	Black	S - 2XL	Bx/100
GDN1500	Orange		

Welder's Gloves



Pyromate® Blue Heeler® Blue & Gold

- High quality blue cow split leather
- Aramid thread stitched
- Lined and welted
- Reinforced palm and thumb
- 406mm gauntlet
- EN388 2344
- EN407 42434X

CODE	SIZES	UOM
GLC60W	One Size	Pair



Pyromate® Black Jack® Black & Gold

- High quality black cow split leather
- Lined and welted
- 406mm gauntlet
- EN388 4143
- EN407 414X4X

CODE	SIZES	UOM
GLC50W	One Size	Pair



Pyromate® Tigga™

- Durable deerskin leather
- Aramid thread stitched
- 340mm gauntlet
- EN388 2121
- EN407 41224X

CODE	SIZES	UOM
GLP13W	L, XL	Pair

ELLIOTTS



KEV Blue

- Premium butt leather, lined
- Reinforced palm/thumb
- Aramid stitching
- 406mm gauntlet
- EN407 41324X
- EN388 4244

CODE	SIZES	UOM
GLC300KB	S - XL	Pair



The Wakatac®

- Red butt leather, lined
- Welted seams
- Aramid stitching
- 406mm gauntlet
- EN407 41324X
- EN388 3243

CODE	SIZES	UOM
GLC300WA	L	Pair

Cotton/Poly Gloves



Poly/Cotton Interlock Knit Wrist

- Lightweight bleached interlock blend
- Knitted wrist band
- Suitable for use as a liner

CODE	SIZES	UOM
GC0146	Men's	Pair
GC0145	Women's	Pair

Poly/Cotton Knit Polka Dot

- Bleached 7 gauge poly/cotton blend knit
- PVC dot grip palm
- Seamless design



CODE	SIZES	UOM
GC0418	Men's	Pair
GC0007	Women's	Pair

Poly/Cotton Knit

- Bleached 7 gauge poly/cotton blend knit
- Seamless ambidextrous design



CODE	SIZES	UOM
GC0450M	Men's	Pair
GC0450L	Women's	Pair

Poly/Cotton Interlock Liner

- Hemmed liner glove
- Bleached for clean appearance
- Reversible design



CODE	SIZES	UOM
GC0440	Men's	Pair
GC0155	Women's	Pair

Cotton Drill Knit Wrist

- Tough cotton drill
- Knit wrist to exclude debris
- Wing thumb design



CODE	SIZES	UOM
GC0410	Men's	Pair
GC0411	Women's	Pair

Electrician's Gloves



Honeywell Electrosoft Latex

- Natural latex base with high dielectric characteristics
- Straight cuff with cut edge
- Glove ratings from 650 to 4,000 volts
- Multiple size & length options
- AS 2225:1994 approved



OVERGLOVE
GLC2012897

Overglove

- Protects Electrosoft gloves from mechanical hazards
- Water repellent cowhide silicone grain leather

CODE	WORKING VOLTAGE	LENGTH (MM)	SIZES	UOM
GRL091607	650	360	8 - 11	Pair
GRL091612	1,000	360	8 - 11	Pair
GRL091613	1,000	410	8 - 11	Pair
GRL091622	3,300	360	8 - 11	Pair
GRL091632	4,000	360	9 - 11	Pair
GLC2012897	1,000	310	8 - 11	Pair



Derma Guard Skin Protectant

- Light and easy to use
- Protects and nourishes
- Non greasy formula
- One application lasts four hours
- Protects against acids, chemicals, odours, resins, mastic, adhesives, and more



CODE	DESCRIPTION	UOM
JHDG50M	Derma Guard Mousse - 50ml	Ea
JHDG150M	Derma Guard Mousse - 150ml	Ea
JHDG500M	Derma Guard Mousse - 500ml	Ea
JHDG100C	Derma Guard Cream - 100ml	Ea
JHDG150C	Derma Guard Cream - 150ml	Ea
JHDG500C	Derma Guard Cream Pump - 500ml	Ea
JHDG2000C	Derma Guard Cream Pump - 2L	Ea
JHDGWALL	Wall Dispenser for 500ml Aerosol Mousse	Ea



Glove Dispenser

- Dispenses quickly & cleanly
- Manages high usage
- Single: 95(H) x 295(W) x 100mm(D)
- Triple: 490(H) x 275(W) x 100mm(D)



CODE	DESCRIPTION	UOM
GDZ41056	Single Box Dispenser	Ea
GDZ41057	Triple Box Dispenser	Ea



By VISIONSafe

Glove Guard Clip

- Double jaw configuration
- Attaches to belt loop, pocket, etc.
- 'Safety Breakaway' feature
- Metal detectable version available



CODE	COLOURS	UOM
MGG1	Various	Ea



Barrier Creams

Water Repellent Barrier Cream

- Protects hands against chemicals, detergents, acids, alkalis
- Relieves and moisturises



Solvent Resistant Barrier Cream

- Protects hands against solvents, steel, dust, oils
- Relieves and moisturises



After Work Moisturising Cream

- Assists in repair of damaged skin
- Relieves and moisturises
- Contains lanolin



CODE	DESCRIPTION	UOM
JHBCWR125	Ultra Clean Water Repellent Barrier Cream - 125ml	Ea
JHBCWR500	Ultra Clean Water Repellent Barrier Cream - 500ml	Ea
JHBCWR1	Ultra Clean Water Repellent Barrier Cream - 1L	Ea
JHBCSR125	Ultra Clean Solvent Resistant Barrier Cream - 125ml	Ea
JHBCSR500	Ultra Clean Solvent Resistant Barrier Cream - 500ml	Ea
JHBCSR1	Ultra Clean Solvent Resistant Barrier Cream - 1L	Ea
JHBCMC125	Ultra Clean After Work Moisturising Cream - 125ml	Ea
JHBCMC500	Ultra Clean After Work Moisturising Cream - 500ml	Ea
JHBCMC1	Ultra Clean After Work Moisturising Cream - 1L	Ea



Glove Clip Keeper

- Twin locking jaws
- Breakaway connecting cord
- Attaches to belts/belt loops



CODE	COLOURS	UOM
MGGCK	Black, Yellow, Orange	Ea

Safety Knives



By VISIONSafe

Fish 200 Safety Knife

- Cuts strapping, string, tape etc.
- Replaceable blades
- Versatile ergonomic design



CODE	COLOUR	UOM
YK002	Green	Ea

Penguin 900 Safety Knife

- Cuts tape, bubble wrap etc.
- Integrated tape cutter
- Ergonomic design with knuckle protection



CODE	COLOUR	UOM
YK004	Orange	Ea

ReAkta Safety Knife

- Easy to replace 60mm blade
- Automatic blade retraction when the knife is shaken, jerked or dropped
- Heavy duty with aluminium blade carrier



CODE	COLOUR	UOM
YK006	Black	Ea

HEIGHT SAFETY



APPLICATION

The Australian workforce experiences a fatal fall from height at least once per week. Half of those fatalities are from heights under 2 metres; some even from as little as 600mm. Safework Australia specifies that height risk assessment is essential for ANY HEIGHT. Height Safety Awareness training is compulsory for all workers who inspect their own harnesses and safety equipment prior to any work at height.

RISK ASSESSMENT

Safework Australia (www.safeworkaustralia.gov.au) has Codes of Practice referencing working at height; included are Managing the Risk of Falls in the Workplace, Preventing Falls in Housing Construction and a Code of Practice for Confined Space. In the event that working at height hazards cannot be eliminated with controls other than personal protective equipment, then the



selection of specific fall prevention equipment, provision of rescue and retrieval equipment, and training to specific competencies must become part of the overall risk management process. Height Safety Training to a specified competency is now an integral part of any work at height undertaking - refer AS/NZS 1891.4:2009. Equipment inspections to manufacturer's requirements must be conducted by competent persons. A record of training and equipment inspection is the primary responsibility of the person conducting a business or undertaking. WHS Regulations detail the management of risk of a fall by a person from one level to another, including requirements to:

1. ensure, so far as is reasonably practicable, that any work involving the risk of a fall is carried out on the ground or on a solid construction
2. provide safe means of access to and exit from the workplace
3. minimise the risk of falls so far as is reasonably practicable by providing a fall prevention device, work positioning system or a fall arrest system.

Do Not Work Alone - A worker making their own connections can make a mistake and must never make their own D-ring connection with the harness already on - a fellow worker should check all connections relating to a harness.

Connector Compatibility - Mixing height safety components from a variety of manufacturers is not recommended, as components that may appear to be compatible may in practice not be. When

selecting systems the user should look to ensure that the hook and "D" are compatible wherever possible. Proper connector compatibility ensures that pressure can't be put on the gate of the connector by the ring you are connecting into i.e. anchor point or rear D.

Rescue - Rescue must always be integral with any fall protection programme.

Suspension Intolerance - This is thought to occur as a result of low blood pressure caused by blood pooling in the lower extremities as an after-effect of a full body harness fall.

SAFETY TIPS

- Consider the workspace below the height work i.e. the need for isolation, barriers and signs.
- Consider interaction with other trades and activities.
- Equipment should be inspected by the user before and after each use.
- Maintain equipment in accordance with the manufacturers' guidelines and AS/NZS 1891.4.
- Ensure the correct size harness is worn.

All workers should be trained in the correct use and maintenance of personal protective equipment.

USEFUL REFERENCES

AS/NZS 1891.4:2009 Industrial fall arrest systems and devices - Selection, use and maintenance.

AS/NZS 1891.1:2007/Amdt 2:2008 Industrial fall arrest systems and devices - Harnesses & ancillary equipment.

AS/NZS 1891.2:2001 Industrial fall arrest systems and devices - Horizontal lifeline and rail systems.

AS/NZS 1891.3:1997 Industrial fall arrest systems and devices - Fall arrest devices.

AS/NZS 2865-2009 Confined spaces.

HEIGHT SAFETY KITS	91
'3M PROTECTA' HEIGHT EQUIPMENT	92
'3M DBI-SALA' HEIGHT EQUIPMENT	94
'3M P50' HEIGHT EQUIPMENT	96
'LINQ' HEIGHT EQUIPMENT	97, 100
TOOL DROP PREVENTION	98

Terminology

1. Work Positioning

A Work Positioning System is one that is designed to hold and sustain the worker at a location and limit the free fall to max. 600mm.

2. Restraint Technique

Control on a worker's movement by use of a fall-arrest system using an adjustable connection to an anchorage preventing movement to a position where free or limited free fall might be possible. Restrained Fall describes the same connections but where the worker maintains a restraint technique over varying distances from the anchorage.

3. Fall Arrest or Free Fall Arrest (FFA)

A system that is designed to stop the free fall of a worker and limit maximum arresting forces on the body to 6kN or less. A fall where the arrest forces begin to take loading in excess of 600mm. The maximum free fall distance is 2m. Limited Free Fall is where anchorage placement or lanyard length limits free fall to less than 600mm.

4. Rescue

A Rescue System designed to raise or lower a worker to safety in the event of an emergency. No free fall or risk to the rescuer should be possible.

5. Suspension

Designed to suspend and support the worker whilst raising or lowering and not allowing free fall.

6. Working Slack

The lifeline distance from a harness attachment point to the anchorage point. Use an adjustable lanyard to limit working slack.

7. Weight Limitation

The weight of a worker including tools. 3M™ lanyards have been designed, tested and certified for a combined worker weight with tools to between 50kg and 160kg. Weight combinations above 160kg must use a rated Self Retracting Lanyard (SRL).

Note: There is no such thing as a safe fall distance.

Anchorage devices must be engineer approved and fitted by a trained specialist.

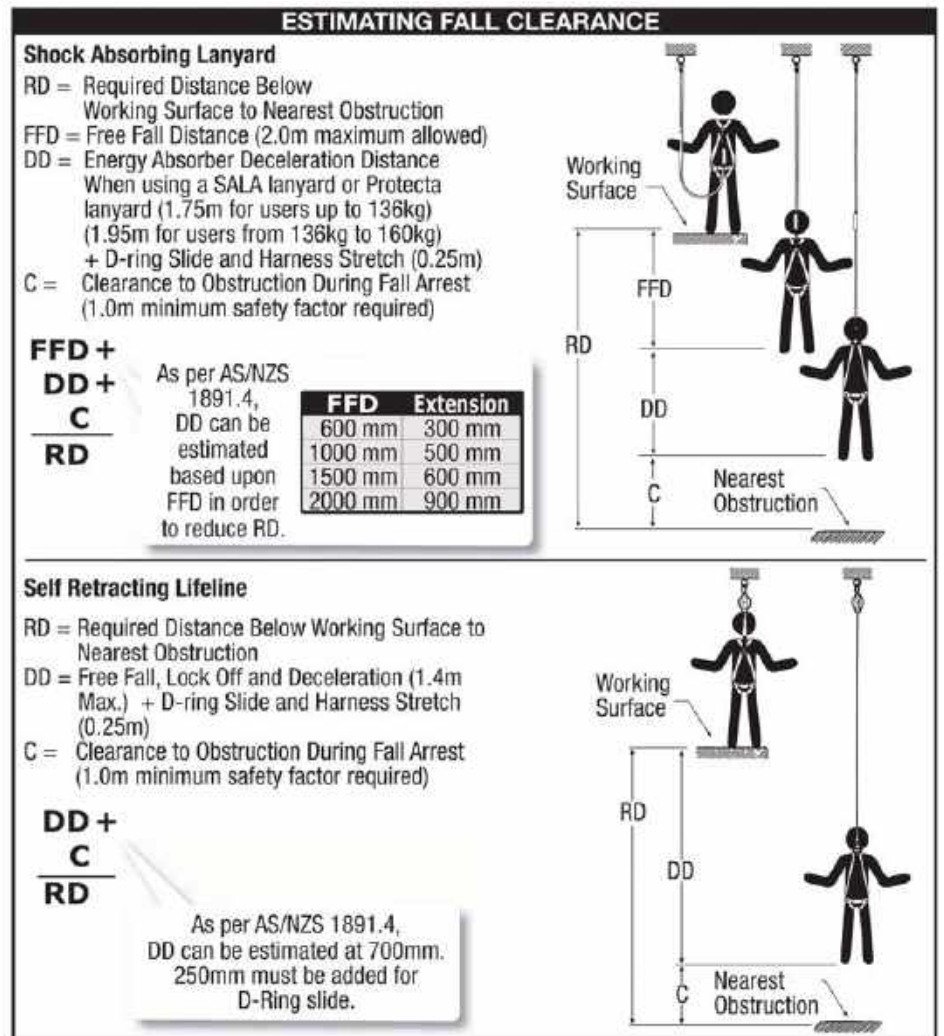
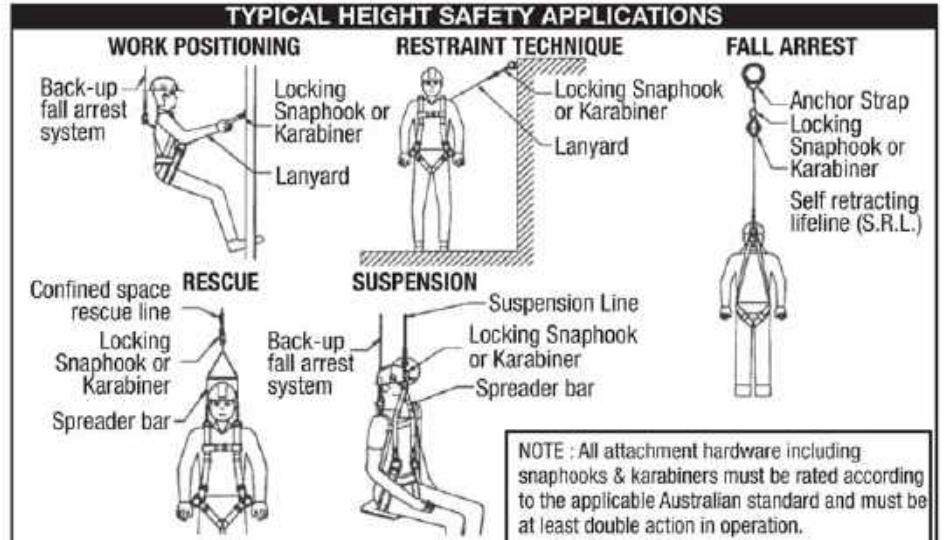

3M™ SAFETY TRAINING

Real World Training with the world's leading height safety company

- World-class training with the industry's best instructors
- Nationally recognised courses approved by ASQA
- Experienced training instructors with backgrounds that include rescue, fire and safety capabilities
- Anytime, anywhere. We will train your workers on-site or they can attend our fully equipped training facilities

Our Range Of Training Courses Include: ▶

Have more specific needs? 3M Safety training offers over 30 different height safety training courses, contact us for more information.

Height Safety Operator (Work Safely At Heights)

This course takes the participant through the theory of working at heights and also includes practical exercises and an introduction to peer rescue.

Height Safety Supervisor

Designed to provide candidates with the necessary skills to be competent as a Height Safety Supervisor as per AS/NZS 1891.4.

Height Safety Manager

Builds on the previous unit skill level of Height Safety Supervisor to consolidate all that is learned and to further develop these skills to Height Safety Manager level as per AS/NZS 1891.4.

Height Safety Equipment Inspector

Provides candidates with the knowledge and techniques to inspect and oversee the care and maintenance of their organisations fall protection equipment.





Protecta P100 Construction Workers Kit

Kit includes:

- Pro Climbing Harness - Medium (AB123M)
- 3.3m Rebel Personal SRL (3100447)
- 1.5m round anchor strap (AM450/150AU)
- Backpack storage bag



CODE	DESCRIPTION	UOM
UFPK410	P100 Construction Workers Kit	Ea



Protecta P100 Roof Workers Kit

Kit includes:

- Pro Climbing Harness - Medium (AB123M)
- 15m kernmantle rope lifeline with integral shock absorbing lanyard
- 1.5m tie-off adaptor anchor strap (AM500/150AU)
- Backpack storage bag



CODE	DESCRIPTION	UOM
UFPK400	P100 Roof Workers Kit	Ea



Protecta P50 Roof Workers Kit

Kit includes:

- Fall Arrest Harness (AB17510AU)
- 15m kernmantle rope lifeline with 1.0m integral shock absorbing lanyard
- 1.5m round anchor strap (AM450/150FAU)
- Reusable carry bucket



CODE	DESCRIPTION	UOM
UFPK1000	P50 Roof Workers Kit	Ea



Protecta P50 Construction Workers Kit

Kit includes:

- Fall Arrest Harness (AB17510AU)
- 1.8m Rebel Personal SRL (3100445)
- 1.5m round anchor strap (AM450/150FAU)
- Reusable carry bucket



CODE	DESCRIPTION	UOM
UFPK1020	P50 Construction Workers Kit	Ea



Delta™ Construction Workers Kit

Kit includes:

- Delta™ All Purpose Harness - Medium (380M-0018)
- 2.4m Talon™ SRL (3101000)
- EZ-Stop™ 2.0m lanyard (Z90203636)
- Tie-off adaptor (E849-015)
- Equipment bag (1900-000)



CODE	DESCRIPTION	UOM
UFPK1900-0004	Construction Workers Kit	Ea



Delta™ Professional Roof Workers Kit

Kit includes:

- Delta™ Roof Workers Harness - Medium (360M-0016)
- 15m Rope and Rope Grab (P6711-015-36-58)
- EZ-Stop™ 1.0m lanyard (Z90103636)
- Screw Gate Karabiner (R-105)
- Tie-off Adaptor (E849-015)
- Equipment bag (1900-000)



CODE	DESCRIPTION	UOM
UFPK1900-0005	Roof Workers Kit	Ea



Self Rescue Unit

- Allows you to lower yourself to safety in the event of being suspended after a fall

- Sealed descent device & rope spool
- Universal harness attachment
- EZ-Link™ D-ring
- Assisted-rescue ring
- Optional rescue pole accessory
- 50 or 100 foot lengths



CODE	DESCRIPTION	UOM
USR3320030	Self-Rescue 50'	Ea
USR3320031	Self-Rescue 100'	Ea
USR3320037	Self-Rescue Training Unit - 30'	Ea
USR8900299	Self-Rescue Pole	Ea



Protecta P100 Riggers Harness

- Front & rear fall arrest rated D-rings
- Confined space retrieval/attachment points
- Easy adjust hardware
- Sub-pelvic strap
- Adjustable chest, shoulder & leg straps
- Protected labels
- Integral adjustable/elasticated lanyard options with scaffold or snap hooks
- Harness storage bag



UBH123



UBH12634

Ideal for rigging, rescue, construction, elevated work platform, confined space, ladder access work and general applications

CODE	DESCRIPTION	SIZES
UBH123	P100 Riggers Harness	S - XL
UBH12634	P100 Riggers Harness Adjustable Lanyard/Scaff Hook	M - XL
UBH12636	P100 Riggers Harness Adjustable Lanyard/Snap Hook	S - XL
UBH12734	P100 Riggers Harness Elasticated Lanyard/Scaff Hook	M - L
UBH12736	P100 Riggers Harness Elasticated Lanyard/Snap Hook	M - L



Protecta P200 Riggers Harness

- New enhanced features
- Quick-Connect buckles
- Rear fall arrest D-ring
- Adjustable chest strap
- ANSI Z359.11-compliant auto-resetting lanyard keepers for fast and easy parking of snap hooks and carabiners
- Comfort pad option has U-shaped neck with moisture wicking padding designed to help reduce chafing and sweat buildup



UBH116167



UBH116167P



UBH116168



UBH116169

CODE	DESCRIPTION	SIZES
UBH116167	P200 Riggers Harness	S - XL
UBH116167P	P200 Riggers Harness c/w Comfort Pads	S - XL
UBH116168	P200 All Purpose Harness c/w Comfort Pads	S - XL
UBH116169	P200 Tower Workers Harness c/w D-rings	S - XL



Protecta P100 All Purpose Harness

- Front, side & rear fall arrest rated D-rings
- Confined space retrieval/attachment points
- Easy adjust hardware
- Sub-pelvic strap
- Integrated shoulder & lower back/hip pads
- Adjustable chest, shoulder & leg straps
- Protected labels
- Harness storage bag



CODE	DESCRIPTION	SIZES
UBH124	P100 All Purpose Harness	S, M, L, XL



Protecta P100 Scaffolders Harness

- Front & rear fall arrest rated D-rings
- Confined space retrieval/attachment points
- Easy adjust hardware
- Sub-pelvic strap
- Padded heavy duty comfort tool belt
- Adjustable chest, shoulder & leg straps
- Protected labels
- Harness storage bag



CODE	DESCRIPTION	SIZES
UBH125	P100 Scaffolders Harness	S, M, L, XL



Anchor Strap

- Securely attaches your fall arrest system to the anchorage



CODE	DESCRIPTION	UOM
UAS500100	1.0m Anchor Strap with Interlocking Rings	Ea
UAS500150	1.5m Anchor Strap with Interlocking Rings	Ea



Pole Strap

- 2.5m length with easy and efficient adjustment system
- Integral wear sleeve



CODE	DESCRIPTION	UOM
UPST25AU	2.5m c/w Adjuster, Snap Hooks and Wear Sleeve	Ea



Shock Absorbing Lanyards

- Ideal for fall arrest, work positioning and restraint
- Minimises shock loads on the body limiting the arresting forces to under 6kN in the event of a fall
- Various styles, lengths and hook/karabiner options are available



CODE	DESCRIPTION	LENGTH	UOM
ULY5293	Single Tail Webbing Lanyard with Double Action Snap Hooks	2m	Ea
ULY52925	Single Tail Webbing Lanyard with Karabiner and Double Action Snap Hook	1m	Ea
ULY529E3	Single Tail Elasticated Webbing Lanyard with Double Action Snap Hooks	2m	Ea
ULY529E5	Double Tail Elasticated Webbing Lanyard with Snap Hook and Two Scaffold Hooks	2m	Ea
ULY529ADJ	0.75 - 2.0m Adjustable Lanyard with Double Action Snap Hooks	2m	Ea
ULY5293W	Single Tail Welders Aramid Fibre Webbing Lanyard with Double Action Snap Hooks	2m	Ea



PRO-Line™ Temporary Horizontal Lifeline

- Provides horizontal movement where there is no permanent safety system
- Built-in shock absorber reduces anchorage loadings
- Fall arrest rated for two users
- Fast set-up, removal and storage with built-in tensioner and carrying bag



CODE	DESCRIPTION	UOM
UHL1200101	18m Temporary Webbing Lifeline	Ea



Rope Grabs & Lifelines

- Ideal for fall arrest situations where the user is required to perform horizontal or angle type work



CODE	DESCRIPTION	UOM
URG400	Viper Rope Grab, suits 10.5 - 11mm Kernmantle Rope, c/w Screw Lock Karabiner (for horizontal use)	Ea
URG415MB	15m System, Kernmantle Rope Lifeline with Karabiners, Backsplice, Adjuster and Lanyard	Ea



Rebel™ Self-Retracting Lifelines

- Swivelling anchorage loop with karabiner
- Self-locking steel snap hook on lifeline
- Rugged, lightweight thermoplastic housing
- Webbing or cable lifeline models available
- Available in a wide variety of lengths from 1.8m to 30m



CODE	DESCRIPTION	UOM
UFA3100447	3.3 m Webbing Lifeline with Double Action Snap Hook and Anchorage Karabiner on Housing	Ea
UFA3590521	10m Galvanised Cable Lifeline with Double Action Swivelling Fall Indicator, Snap Hook and Anchorage Karabiner on Housing	Ea



Tripod & Winches

- Lightweight, portable aluminium tripods are ideal for confined space manhole entry and retrieval
- Retrieval self-retracting lifeline or rescue winch easily attach to tripod for a complete confined space system



CODE	DESCRIPTION	UOM
UTP100	1.35 to 2.35m Tripod	Ea
URB3591002	Retrieval SRL, 15m Galvanised Cable	Ea
UWH200I20	Rescue Winch, 20m, includes Mounting Bracket	Ea
UCSK600AU	Confined Space Kit, incl. Tripod, Winch, Bag & Pulley	Ea



Anchorage Devices

CODE	DESCRIPTION	UOM
URA210	Fixed Anchorage Plate	Ea
URA211	Fixed Anchor D-ring	Ea
URA2199938	RailDog™ HI-VIS Sliding Rail Anchor	Ea



Karabiners & Hooks

CODE	DESCRIPTION	UOM
UKR514	16mm Gate Opening, Double Action, Auto-lock	Ea
UKR593	50mm Gate Opening, Double Action, Auto-lock	Ea
UHK592	89mm Gate Opening, Double Action, Anchor Hook	Ea





EXOFIT NEX™ Riggers Harness

- Front & rear Tech-Lite™ aluminium D-rings
- Suspension trauma straps
- Confined space retrieval/attachment points
- Impact indicator
- REPEL™ technology webbing
- Non-slip hybrid comfort padding
- Duo-Lok™ quick-connect buckles
- Revolver™ vertical torso adjusters
- Harness storage bag



CODE	DESCRIPTION	SIZES	UOM
UBH603	Riggers Harness	S, M, L, XL	Ea



DELTA™ Riggers Harness

- Large rear fall arrest rated stand-up D-ring
- Front fall arrest rated D-ring
- Confined space retrieval/attachment points
- Quick-connect buckles
- Corrosion resistant hardware
- Fully adjustable
- REPEL™ technology webbing
- Harness storage bag



CODE	DESCRIPTION	SIZES	UOM
UBH803-0018	Riggers Harness	S, M, L, XL	Ea



EXOFIT NEX™ Confined Space Harness

- Front, rear & side Tech-Lite™ aluminium D-rings
- Padded lower back/hip pad
- Suspension trauma straps
- Confined space attachment points
- Impact indicator
- REPEL™ technology webbing
- Non-slip hybrid comfort padding
- Duo-Lok™ quick-connect buckles
- Revolver™ vertical torso adjusters
- Harness storage bag



CODE	DESCRIPTION	SIZES	UOM
UBH623	Confined Space Harness	S, M, L, XL	Ea



DELTA™ All Purpose Harness

- Large rear fall arrest rated stand-up D-ring
- Confined space retrieval/attachment points
- Front fall arrest rated D-ring
- Waist belt with side D-rings
- Quick-connect buckles
- Corrosion resistant hardware
- Fully adjustable
- REPEL™ technology webbing
- Harness storage bag



CODE	DESCRIPTION	SIZES	UOM
UBH823-0018	All Purpose Harness	S, M, L, XL	Ea



Harness Accessories

Suspension Trauma Straps

- Helps prevent the effects of suspension trauma after a fall by allowing the casualty to stand up in their harness



UBHZ9501403

Harness Spreader Bar

- Typically used with a winch & davit arm or tripod assembly to raise and lower a worker into and out of a confined space



UBHZ522

CODE	DESCRIPTION	UOM
UBHZ9501403	Suspension Trauma Straps - Set of 2	Ea
UBHZ522	Harness Spreader Bar c/w Karabiner Connections	Ea



DELTA™ Tower Workers Harness

- Large rear fall arrest rated stand-up D-ring
- Front fall arrest/belay loops
- Confined space retrieval/attachment points
- Quick-connect buckles
- Pole/restraint D-rings
- Corrosion resistant hardware
- Fully adjustable
- REPEL™ technology webbing
- Padded waist belt with side D-rings
- Harness storage bag



CODE	DESCRIPTION	SIZES	UOM
UBH853-0018	Tower Workers Harness	S, M, L, XL	Ea



Anchor Straps

- Ideal for use as an anchorage connector for fall arrest, restraint, work positioning, suspension or rescue systems
- i-Safe™ enabled



UAS849

UAS1003583

CODE	DESCRIPTION	UOM
UAS849-012	Ring Tie-off Adaptor 1.2m (also 0.5/0.8/1.0/1.5/2.0)	Ea
UAS1003583	Round Tie-off Adaptor 1.2m (also 0.6/1.0/1.5/2.0)	Ea



Pole Strap

- Easy and efficient adjustment system
- Integral wear sleeve
- i-Safe™ enabled
- Available in a variety of lengths and hook options



CODE	DESCRIPTION	UOM
UPS601-025	2.5m c/w Adjuster, Snap Hooks & Wear Sleeve	Ea



Force2™ Shock Absorbing Lanyards

- Extremely compact and lightweight energy absorber
- Exclusive Hi-10™ energy absorption system limits arresting forces to under 6kN in the event of a fall
- User friendly self locking connectors with 16kN rated gates
- Various styles, lengths and hook/karabiner options are available
- Protected labels, equipped with i-Safe™



CODE	DESCRIPTION	UOM
ULY11200909	Single Tail, Adjustable, Double Action Snap Hooks	Ea
ULY12202519E	Double Tail, Elasticated, Double Action Snap and Scaffold Hooks	Ea
ULY10200909R	Single Tail, Rope, Double Action Snap Hooks	Ea
ULY10204545WR	Single Tail, Wire Cable, SS Triple Action Karabiners	Ea



Self-Retracting Lifelines

- Various styles, configurations and lengths from 1.8m to 40m are available to suit a variety of applications
- Energy absorption system maintains safe fall arrest forces
- Speed sensing brake system stops a falling worker within centimetres
- i-Safe™ enabled



UFA3101330

UFA3504430

CODE	DESCRIPTION	UOM
UFA3101000	Talon™ SRL - 2.4m Webbing Lifeline with Quick Connect Mount Handle and Snap Hook	Ea
UFA3101330	Nano-Lok™ SRL - 1.8m Webbing Lifeline with Snap Hook and Quick Connector for Harness Mounting	Ea
UFA3101639	Nano-Lok™ LE SRL - 2.4 m Webbing Lifeline with Karabiner and Quick Connector for Harness Mounting	Ea
UFA3504430	Ultra-Lok™ SRL - 10m Galvanised Cable Lifeline with Impact Indicating Swivel Snap hook	Ea
UFA3400806	Sealed-Blok™ SRL - 9m Galvanised Cable Lifeline with Triple Action Swivel Karabiner and Carry Handle	Ea



Roof Anchors

- DBI-SALA's range of roof anchors are available in a wide range to suit a variety of applications



URA4551

CODE	DESCRIPTION	UOM
URA2101630	D-Ring with Anchorage Plate	Ea
URA4551	Purlin Mounted Low Profile - Corrugated Iron Application	Ea



Sayline™ Temporary Horizontal Lifeline - Rope System

- Up to two users per system
- Includes rope, tensioner, two tie-off adaptors and storage bag
- Specify length when ordering



CODE	LENGTHS AVAILABLE	UOM
UHL2000	15m, 20m, 25m, 30m	Ea



Rope Grabs & Lifelines

- Lifeline assembly systems and rope grabs are ideal for horizontal/angle work in fall arrest applications
- Lifeline assembly systems available in a variety of lengths

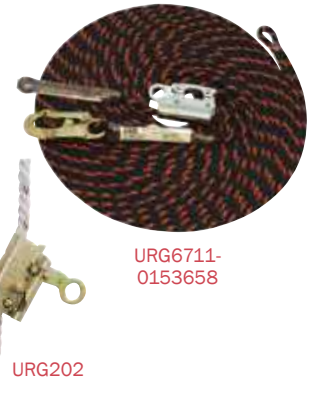

URG202

CODE	DESCRIPTION	UOM
URG6711-0153658	15m System, Kernmantle Rope Lifeline with Manual Rope Grab, Snap Hook, Sewn Thimble Eye and Sewn End Stop	Ea
URG202	Cobra Automatic Rope Grab, for 12-14mm 3 Strand Rope or 11-13mm Kernmantle Rope (for vertical/horizontal use)	Ea
URG202-02AU	COBRA Automatic Rope Grab, with Karabiner and Integral Shock Pack, for 12-14mm 3 Strand Rope or 11-13mm Kernmantle Rope (for vertical/horizontal use)	Ea



Tripod & Winches

- Aluminium tripod with rectangular legs
- Quick-mount bracket for attachment of mechanical devices, eyebolt anchor points, adjustable locking legs with safety chain
- Range of self-retracting lifelines with retrieval winches available



CODE	DESCRIPTION	UOM
UTP8000000	2.1m Aluminium Tripod	Ea
URB3400955	15m Sealed Blok™ Retrieval SRL	Ea
UWH8102001	18m Salalift™ II Winch	Ea
URBZ3401025	Mounting Bracket, to fit Sealed Blok Retrieval SRL's to Tripod Leg	Ea



Protecta P50 Construction Harness

- Construction harness with front, rear and side D-rings for multiple work positions
- Confined space shoulder retrieval attachment points
- Waist belt and padded hip/lower back pad



CODE	DESCRIPTION	SIZE	UOM
UBH1390062A	P50 Construction Harness	M	Ea



Protecta P50 Industrial Harness

- Industrial harness with front and rear fall arrest rated D-rings
- Adjustable leg, chest and pelvic straps



CODE	DESCRIPTION	SIZE	UOM
UBH1390061A	P50 Industrial Harness	M	Ea



Rollgliss™ R550 Rescue & Escape Device - Escape Kit

- Kit includes R550 twin brake descender and telescopic pole where indicated
- Connecting karabiner on housing
- 9mm kernmantle rope with snap hooks on both ends
- Storage/deployment bag
- Also available:
With pole: 60m/70m/100m/150m
Without pole: 100m/120m/150m



CODE	DESCRIPTION	UOM
URK19070010	10.0m R550 Rollgliss Rescue/Escape Kit & Pole	Ea
URK19070020	20.0m R550 Rollgliss Rescue/Escape Kit & Pole	Ea
URK19070030	30.0m R550 Rollgliss Rescue/Escape Kit & Pole	Ea
URK19070040	40.0m R550 Rollgliss Rescue/Escape Kit & Pole	Ea
URK19070050	50.0m R550 Rollgliss Rescue/Escape Kit & Pole	Ea
URK3329010	10.0m R550 Rollgliss Rescue/Escape Kit	Ea
URK3329020	20.0m R550 Rollgliss Rescue/Escape Kit	Ea
URK3329040	40.0m R550 Rollgliss Rescue/Escape Kit	Ea
URK3329060	60.0m R550 Rollgliss Rescue/Escape Kit	Ea



Protecta P50 Industrial Harness c/w Integral Lanyard

- Industrial harness with front and rear fall arrest rated D-rings
- Adjustable leg, chest and pelvic straps
- Integral adjustable 2.0m lanyard
- Option for snap hook or scaffold hook end



CODE	DESCRIPTION	SIZE	UOM
UBH1390063A	P50 Industrial Harness with Integral Lanyard & Snap Hook	M	Ea
UBH1390064A	P50 Industrial Harness with Integral Lanyard & Scaff Hook	M	Ea



P50 Anchor Strap

- 2.0m fast & safe tie-off adaptor
- Maximum arresting force 6kN
- Minimum breaking strength 15kN



CODE	DESCRIPTION	UOM
UAS5900583A	P50 2.0m Tie-Off Adaptor	Ea



P50 EZ-Stop™ Shock Absorbing Lanyards

- 2.0m adjustable length single tail web lanyard with snap hooks
- 2.0m twin tail web lanyard with 65mm scaffold hooks



CODE	DESCRIPTION	UOM
ULY1390066A	P50 EZ-Stop Single Tail c/w Snap Hooks	Ea
ULY1390065A	P50 EZ-Stop Twin Tail c/w Scaffold Hooks	Ea



High Capacity 5-Piece Hoist System

- Designed for manhole and confined space entry/retrieval applications
- Lightweight, corrosion resistant aluminium construction
- Pivoting davit with height adjustable mast for ease of rescue and overhead clearance restrictions
- Lower base adjusts to fit most standard entries
- Mechanical devices and accessories sold separately

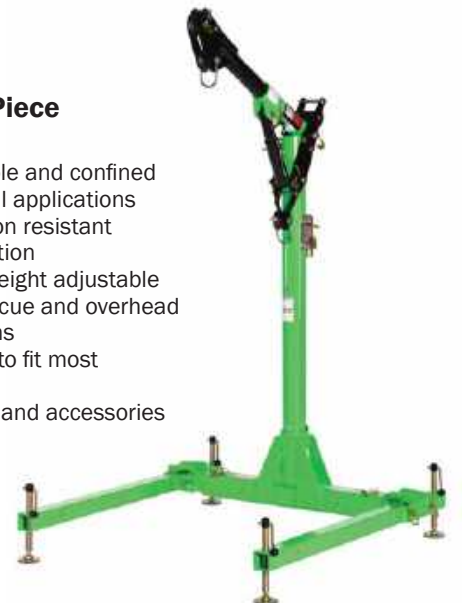

CODE	DESCRIPTION	UOM
UHS8000132	High Capacity Hoist System	Ea



Essential Harness

- High tenacity UV stabilised pebble weave webbing
- Large dorsal D ring
- Extended belay loops
- Closed loop webbing system on rear dorsal D
- Articulated chest strap and shoulder adjustment points
- Padding under buckles
- Hot Works Welders Harness available with Kevlar/Nomex webbing for high resistance to heat



CODE	DESCRIPTION	SIZES	UOM
UBH101	Essential Harness	S, M/L, XL/2XL	Ea
UBH101QR-HW	Essential Hot Works Welders Harness	M/L	Ea



Tactician Riggers Harness

- High tenacity UV stabilised pebble weave webbing
- Rear barr D allows easier access
- Extended belay loops
- Closed loop webbing system on rear dorsal D
- Articulated chest strap and shoulder adjustment points
- Confined space rescue loops
- Suspension trauma strap
- Padding under buckles



CODE	DESCRIPTION	SIZES	UOM
UBH201	Tactician Riggers Harness	S, M/L, XL/2XL	Ea



Elite Riggers Harness

- High tenacity UV stabilised pebble weave webbing
- Rear barr D allows easier access
- Extended belay loops
- Closed loop webbing system on rear dorsal D
- Padding under buckles
- Air COOL padded shoulder straps
- Suspension trauma strap
- Articulated chest strap and shoulder adjustment points
- Confined space rescue loops
- Padded legs for force disperison



CODE	DESCRIPTION	SIZES	UOM
UBH301	Elite Riggers Harness	S, M/L, XL/2XL	Ea



Essential Standard Roofers Kit

Kit includes:

- Essential harness
- 15m kernmantle rope with rope grab & thimble eye (RKR015)
- Single leg webbing lanyard with 2 snap hooks (WLO1SNSN)
- 25mm anchor strap endless - 1.5m (HSASE2515)
- 2 x screw gate karabiner
- Kit bag (HSKB710)
- Basic Roofers Kit version available



STANDARD ROOFERS KIT

CODE	DESCRIPTION	UOM
UFPKRSTD	Essential Standard Roofers Kit	Ea
UFPKRBCS	Essential Basic Roofers Kit	Ea



Anchor Tetha T-Bar

- Suitable for fall arrest applications on metal roofs only



CODE	UOM
URATBA	Ea



Anchor Tetha V-Bar

- For use on metal or tile roofs
- 280mm - all purpose metal roofs
- 500mm - Trimdeck/Custom Orb roofs



CODE	DESCRIPTION	UOM
URATPS280	280mm Tetha	Ea
URATPS500	500mm Tetha	Ea



Pole Strap

- 2.0m adjustable pole strap c/w two snap hooks



CODE	UOM
UPS20SN	Ea



Double Shock Absorbing Lanyard

- Double elasticated c/w 1 double action karabiner & 2 triple action Scaff Hooks - 2.0m



CODE	UOM
ULYE2KDST	Ea



Anchor Strap

- 25mm anchor strap endless - 1.5m



CODE	UOM
UAASE2515	Ea



Single Shock Absorbing Lanyard

- Single adjustable c/w 2 triple action karabiners - 2.0m



CODE	UOM
ULYA1SNSN	Ea



Single Shock Absorbing Lanyard

- Single webbing c/w 2 snap hooks - 2.0m



CODE	UOM
ULY01SNSN	Ea



Single Adjustable Shock Absorbing Lanyard

- Single webbing c/w 1 snap hook & 1 double action karabiner - 2.0m



CODE	UOM
ULYA1KDSN	Ea

3M

D-Ring Attachment Points

- Creates instant attachment point allowing tools to be tethered safely
- Can be attached to virtually any tool using 3M Quick Wrap Tape
- Dual D-rings allow for 100% tool tie-off during tool transfers



CODE	DESCRIPTION	UOM
UDT1500003	D-Ring 13 x 57mm, 0.9kg Capacity	Pk/10
UDT1500007	D-Ring 25 x 89mm, 2.3kg Capacity	Pk/10

3M

Quick Wrap Tape

- Used with 3M D-rings and tool cinch attachments to create instant tethering points on virtually any tool
- Leaves no residue behind
- Inner fibreglass webbing increases the strength of the tape and makes the tape resistant to sharp objects



CODE	DESCRIPTION	UOM
UDT1500174	Quick Wrap Yellow Heavy Duty, 25.4mm Wide	2.7m Roll
UDT1500171	Quick Wrap Blue Heavy Duty, 25.4mm Wide	5.5m Roll

3M

Bungee Tether Tool Lanyards

- Designed to be used with most hand tools up to 4.5kg/15.9kg
- Features elasticated webbing and self-locking karabiners that prevents accidental opens and automatically close



CODE	DESCRIPTION	UOM
UDT1500047	0.8 - 1.2m Hook2Loop Bungee Tether, 4.5kg Capacity	Ea
UDT1500049	0.8 - 1.3m Hook2Loop Bungee Tether, 15.9kg Capacity	Ea

3M

Coil Tether Tool Lanyards

- Use from holsters, belts, harnesses, tool pouches and wristbands
- Lightweight and ultra compact
- Vinyl coated
- Designed to stay out of the way when not in use
- Compact hard hat coil tether allows for fast and easy tethering of hard hats



CODE	DESCRIPTION	UOM
UDT1500159	0.1 - 1.6m Hook2Hook Coil Tether, 2.3kg Capacity	Ea
UDT1500067	0.05 - 0.6m Trigger2Trigger Coil Tether, 2.3kg Capacity	Ea
UDT1500178	0.1 - 0.9m Hard Hat Tether, 0.9kg Capacity	Pk/10

3M

Tool Cinch Attachments

- Allows users to quickly secure even the most difficult to tether tools/equipment
- V-ring attachment point
- Stabilisation wings can be used to keep tool cinch attachments in place using 3M Quick Wrap Tape



CODE	DESCRIPTION	UOM
UDT1500013	V-ring Attachment - 1 Stabilisation Wing, 15.9kg Capacity	Ea
UDT1500015	V-ring Attachment - 2 Stabilisation Wings, 15.9kg Capacity	Ea
UDT1500017	V-ring Attachment - 2 Stabilisation Wings, 36.3kg Capacity	Ea

3M

Heat Shrink

- Protects 3M Quick Wrap Tape against harsh work environments
- Apply heat using a heat gun to make heat shrink link shrink around Quick Wrap Tape
- Available in a variety of sizes



CODE	DESCRIPTION	UOM
UDT1500019	Shrink Link, 19 x 45mm	Pk/25
UDT1500020	Shrink Link, 25.4 x 51mm	Pk/25

3M

Hook2Loop/Rail Tool Lanyard

- Designed to be used with most hand tools up to 15.9/36.3kg
- Features tubular webbing and self-locking karabiners that prevents accidental opens and automatically close



CODE	DESCRIPTION	UOM
UDT1500050	1.8m Hook2Rail Lanyard, Medium Duty, 15.9kg Capacity	Ea
UDT1500052	1.8m Hook2Rail Lanyard, Heavy Duty, 36.3kg Capacity	Ea

3M

Comfort Tool Belt

- Heavy-duty outer shell and high-density foam core for strength and comfort
- Modular design allows user to customise their own holster and pouch system
- Accommodates a wide selection of optional tool belt holsters, tool lanyards, and tool pouches



CODE	DESCRIPTION	SIZE	UOM
UDT1500110	Tool Belt with Extra Padding	S - M	Ea
UDT1500111	Tool Belt with Extra Padding	L - XL	Ea
UDT1500112	Tool Belt with Extra Padding	2XL - 3XL	Ea



Adjustable Radio Holster

- Adjusts to the size of virtually any handheld radio or mobile phone
- Can be used from a belt or harness
- Includes coil tether and micro D-ring attachment point for device



UDT1500088

CODE	DESCRIPTION	UOM
UDT1500088	Adjustable Radio Holster	Ea
UDT1500089	Adjustable Radio Holster, Clip2Loop Coil Tether & Micro D-Ring	Ea



Tape Measure Holster

- Neoprene sleeve, designed to be used with virtually any tape measure, allowing it to be safely tethered and holstered
- Includes a 3M retractor
- Features Beacon™ HI VIS reflectors

UDT1500100
(TAPE MEASURE NOT INCLUDED)



CODE	DESCRIPTION	UOM
UDT1500098	Tape Measure Retractor Belt Holster	Ea
UDT1500099	Tape Measure Sleeve	Ea
UDT1500100	Tape Measure Retractor Belt Holster & Sleeve Combo	Ea



TOOLS NOT INCLUDED

Single Tool Holster with Retractor

- Attaches to a belt or harness
- Features Beacon™ HI VIS reflectors and Quick-Mag™ magnetic tool staging system
- Equipped with D-rings and a 3M retractor
- Bottom drain vent for work in wet conditions



UDT1500102

UDT1500105

CODE	DESCRIPTION	UOM
UDT1500102	Single Tool Belt Holster with Retractor	Ea
UDT1500105	Single Tool Belt Holster with Retractor Extra Deep	Ea



Drill Battery Holster

- Unique sleeve design conforms to the size of virtually any drill battery
- Sleeve is cinched to the drill, allowing the drill to be tethered off with a 3M tool lanyard while being used at height
- Designed to be used with most drill batteries or other battery powered hand tools

EXAMPLE OF USE



CODE	DESCRIPTION	UOM
UDT1500090	Drill Battery Holster/Sleeve	Ea



Small Parts Pouch

- Innovative self-closure system that traps objects inside, making it nearly impossible for them to fall out
- Easy to retrieve objects since no opening or closing is necessary
- Compatible with most tool belts



UDT1500119

UDT1500122

CODE	DESCRIPTION	UOM
UDT1500119	Canvas, Black	Ea
UDT1500122	Vinyl, Yellow with Black Trim	Ea



UDT1500134

Standard Safe Bucket

- Built-in connection points that tools can be tethered to
- Innovative hook and loop closure system guards against spills and dropped objects during transport, lifting and use
- Puncture resistant base, heavy-duty hoisting/shoulder strap and autolock karabiner
- Optional hard body insert with pockets available



UDT1500141
(TOOLS NOT INCLUDED)

CODE	DESCRIPTION	UOM
UDT1500134	Canvas with Hook & Loop Closure, 45.4kg Load Rated	Ea
UDT1500140	Vinyl with Hook & Loop Closure, 113.4kg Load Rated	Ea
UDT1500141	Hard Body Safe Bucket Insert with 4 Inner Pockets	Ea



Adjustable Wrist Bands

- Hook and loop system to adjust to any wrist size
- Built-in cord model allows quick attachment of tools directly to the wristband
- Model with built-in retractor and attached trigger can be used to quickly work with a variety of hand tools



UDT1500082

UDT1500086

UDT1500084

CODE	DESCRIPTION	UOM
UDT1500082	With D-Ring, 2.3kg Capacity	Ea
UDT1500084	With Cord, 2.3kg Capacity	Ea
UDT1500086	With Retractor & Trigger, 0.5kg Capacity	Ea



Pullaway Wrist Band

- Features an elastic strap that conforms to the users wrist size automatically
- Easily tether off tools using the sewn on D-ring connection point
- Slim profile pullaway wristbands also available



CODE	DESCRIPTION	UOM
UDT1500072	Medium, 2.3kg Capacity	Ea



Tool Lanyard Double Action Karabiner to Loop Tail

- 80cm length extends to 120cm
- Max WLL 5kg



CODE	DESCRIPTION	UOM
UDTTLKDLT	Tool Lanyard	Ea



Tool Lanyard 2 Swivel Snap Hooks

- 80cm length extends to 120cm
- Max WLL 1.86kg



CODE	DESCRIPTION	UOM
UDTLSNSN	Tool Lanyard	Ea



Tool Lanyard Double Action Karabiner & Detachable Tool Strap

- 60cm length extends to 80cm
- Max WLL 0.6kg



CODE	DESCRIPTION	UOM
UDTLKDDS	Tool Lanyard	Ea



Twin Tail Tool Lanyard 3 Double Action Karabiners

- 80cm length extends to 120cm
- Max WLL 5kg



CODE	DESCR.	UOM
UDTTL2TTKDKD	Tool Lanyard	Ea



Hard Hat Lanyard

- Uses cap slots for attachment



CODE	DESCRIPTION	UOM
UDTHHL	Hard Hat Lanyard	Ea



Self-Fusing Silicone Tool Tape

- Long lasting adhesion & grip
- 25mm x 10m



CODE	DESCRIPTION	UOM
UDTST	Tool Tape	Ea



D-Ring Attachment Point

- HI VIS orange tail
- Pack of 3
- Also available: 10cm, 20cm



CODE	DESCR.	UOM
UDTWTO-15	15cm	Ea



Flexible Mesh Grip Sock

- Expandable stainless steel mesh
- Swivel connection
- Also available: 30cm, 40cm



CODE	DESCRIPTION	UOM
UDTWTS-20	20cm	Ea



Elite Industrial Lever Hoist

- Heavy duty lever operated manual device
- Provides incremental adjustment used to lift, lower or pull a heavy load
- Can be used for tensioning
- Commercial options available
- Capacity options: 0.75T - 6T
- Standard lift height: 1.5m
- Overload protection & sealed dust gasket
- AS 1418.2 & AS 2321



CODE	DESCRIPTION	UOM
UMLHIO3	Lever Hoist 3.0T	Ea



Essential Commercial Chain Block

- Manually operated chain device
- Uses a series of gears providing a mechanical advantage to lift and lower significant loads
- Industrial options available
- Capacity options: 0.25T - 3T
- Standard lift height: 3.0m - 6.0m
- AS 1418.2 & AS 2321



CODE	DESCRIPTION	UOM
UMCBC01	Chain Block 1.0T	Ea



Round Slings

- 100% high tenacity UV resistant polyester
- Working load designated by international protocol for colour coded load ratings
- Capacity: 1T - 10T
- WLL 7:1
- AS 4497.1



CODE	DESCRIPTION	UOM
UMSR...	Specify weight & length	Ea



Flat Slings

- 100% high tenacity UV resistant polyester double ply flat slings
- Working load designated by international protocol for colour coded load ratings
- Capacity: 1T - 10T
- WLL 7:1
- AS 1353.1



CODE	DESCRIPTION	UOM
UMSF...	Specify weight & length	Ea



Ratchet Tie-Down Straps

- High tenacity UV resistant, polyester lashing webbing
- High strength galvanised ratchet buckles
- Zinc plated interlocking J-hooks and keeper
- Capacity: 0.75T - 2.5T
- 2.5T also available in Pink, supporting the McGrath Foundation



CODE	DESCR.	UOM
UMRTD255J	0.75T	Ea
UMRTD356J	1.5T	Ea
UMRTD509J	2.5T	Ea

UMRTD509J



HEALTH & HYGIENE

APPLICATION

Health and Hygiene considerations apply to almost every workplace and cover a broad range of potential hazards. Workplaces should have a range of responses to their Health and Hygiene needs including both preventative and emergency response solutions.

RISK ASSESSMENT

The Safe Work Australia Code of Practice 'Managing the Work Environment & Facilities' provides guidelines that address typical issues relating to Health & Hygiene.

First Aid

First Aid kit selection should be based on a risk assessment of the type of work being carried out, the location and the number of workers (trained first aid officers may be necessary). The Safe Work Australia Code of Practice 'First Aid in the Workplace' provides practical guidance.

Hydration

Dehydration in the workplace can lead to safety issues as a result of reduced cognitive abilities, performance and reaction times. Strategies covering pre-shift, during and post-shift hydration should be considered. It is critical to ensure workers understand the various hydration strategies they can implement and are given the necessary tools to minimise dehydration.

Hand Cleaners

Hand washing facilities must be provided to enable workers to maintain good standards of personal hygiene and avoid work related skin complaints. Hand cleaners should be selected in response to the specific work environment and hazards.

The correct approach to hand cleaning is one that considers all aspects including pre work protection, using appropriate cleaners, use of antibacterial sanitisers and after work moisturising creams that help restore skin condition.

Sunscreens

Outdoor workers should have access to sunscreens to be used in conjunction with other sun protection strategies. Protection against solar ultraviolet (UV) exposure is critical given that in Australia two out of three people will develop some form of skin cancer during their lifetime. SPF50+ sunscreens with UVA and UVB broad spectrum coverage provide the best protection.

Defibrillators

Providing an automated external defibrillator can reduce the risk of fatality from cardiac arrest. It is a useful addition for workplaces where there is a risk of electrocution or where there are large numbers of members of the public. Automated external defibrillators are designed to be used by trained or untrained persons.

(Source: Safe Work Australia, First Aid in the Workplace, released July 2012)

Drug & Alcohol Testing

Alcohol and Drug testing programmes may play an active role in the prevention, detection and control of alcohol and illicit drugs use in the workplace.

Drug and Alcohol Policies are an essential component of managing workplace risks for many industries, especially for those with the highest risks of catastrophic industrial accidents. Programmes should be supported by clearly communicated policies and training, and adopt a consultative approach.

USEFUL REFERENCES

www.safeworkaustralia.gov.au Code of Practice - First Aid in the Workplace.

AS/NZS 2604.2012 Sunscreen products - Evaluation and classification.

AS 1223-1991 Industrial Hand Cleaners

Safe Work Australia Code of Practice "Managing the Work Environment & Facilities".

SAFETY TIPS

- Ensure First Aid kit contents are not 'out of date' and are restocked as soon as possible.
- When it comes to hydration don't rely on thirst as it is not a reliable indicator.
- The strongest hand cleaner is not always necessary – select the mildest possible cleaner possible.
- Sunscreen should be applied at least 15 minutes before sun exposure - and reapplied every two hours.

All workers should be trained in the correct use and maintenance of personal protective equipment.

FIRST AID	102
DEFIBRILLATORS/DRUG TESTING.....	105
HYDRATION	106
HAND CLEANERS	108
SUNSCREENS	109
CLEANING DISPOSABLES	110
CLEANING CHEMICALS	110

Trafalgar First Aid Kit Guide

WORKPLACE PORTABLE KITS

WP1 Portable	
Soft Case	Polypropylene Hard Case
Indoor Mobility Low dust and minimal moisture areas which require a portable first aid kit.	Indoor/Outdoor Mobility Durable and robust, suitable for large work sites that are prone to dust and wet areas, which require a portable first aid kit.
<ul style="list-style-type: none"> • Offices • Buildings • Schools 	<ul style="list-style-type: none"> • Trades People • Offices • Buildings • Schools



WP1

Workplace FIRST AID KITS - Portable

Includes content recommended in Safe Work Australia First Aid in the Workplace Code of Practice.



Soft Case

- Soft, durable case with shoulder strap
- Internal compartments keep contents secure
- Reflective strip, making visibility easy in an emergency
- Case dimensions: 310mm (W) x 220mm (H) x 130mm (D)

UP TO
25
PEOPLE



Hard Case

- Portable kit made from robust and durable polypropylene plastic
 - Carry handle for convenience
 - Includes additional tray for easy storage
- Case dimensions: 420mm (W) x 200mm (H) x 230mm (D)

CODE	DESCRIPTION	UOM	CODE	DESCRIPTION	UOM
AFK876476	WP1 First Aid Kit Soft Case	Ea	AFK876477	WP1 First Aid Kit Hard Case	Ea
AFR876480	Refill Contents Only	Ea	AFR876480	Refill Contents Only	Ea

WORKPLACE MOUNT KITS

WM1 Wall Mount	
Metal Hard Case	ABS Plastic Hard Case
Indoor/Outdoor Fixture Harsh environments that require maximum durability.	Indoor Fixture Wash down and dust areas.
<ul style="list-style-type: none"> • Agricultural Sheds • Building Sites • Construction/Commercial Sites • Mines • Warehouses • Workshops 	<ul style="list-style-type: none"> • Offices • Manufacturing Plants • Schools • Laboratories • Commercial Kitchens • Agricultural Sheds



WM1

Workplace FIRST AID KITS - Wall Mount

Includes content recommended in Safe Work Australia First Aid in the Workplace Code of Practice.

Metal Case

- Sturdy metal construction
- Internal shelving for a quick response to first aid
- Case dimensions: 240mm (W) x 385mm (H) x 115mm (D)



UP TO
25
PEOPLE

Plastic Case

- ABS plastic construction
- Case includes an 'O' ring to help resist dust and water
- Features shelving and compartments for easy storage
- Case dimensions: 300mm (W) x 390mm (H) x 150mm (D)



CODE	DESCRIPTION	UOM	CODE	DESCRIPTION	UOM
AFK876478	Workplace Metal Case First Aid Kit	Ea	AFK876479	Workplace Plastic Case First Aid Kit	Ea
AFR876480	Refill Contents Only	Ea	AFR876480	Refill Contents Only	Ea

VEHICLE KITS

PV1 HV1 Portable	
Soft Case	Soft Case
Personal Vehicles Suitable for toolbox or glove box storage.	Heavy Vehicles Recommended for low dust and minimal moisture areas which require a portable first aid kit.
<ul style="list-style-type: none"> • Fleet Cars • Couriers • Sales People 	<ul style="list-style-type: none"> • Heavy Vehicles • Trucks • DG Transportation • Trades People

PV1 Passenger Vehicle FIRST AID KIT



- Compact and portable
- Easily fits into the glove box or boot of the car
- Soft durable case with compartments
- Case dimensions: 140mm (W) x 210mm (H) x 60mm (D)



1 KIT
PER VEHICLE

HV1 Heavy Vehicle FIRST AID KIT

- Ideal for trucks, vehicles transporting dangerous goods and earthmoving equipment
- Includes content recommended in Safe Work Australia First Aid in the Workplace Code of Practice, plus additional 500ml Eye Wash and First Aid sticker
 - Soft durable case with compartments and shoulder strap
- Case dimensions: 310mm (W) x 220mm (H) x 130mm (D)



CODE	DESCRIPTION	UOM	CODE	DESCRIPTION	UOM
AFK876474	Passenger Vehicle First Aid Kit	Ea	AFK876475	Heavy Vehicle First Aid Kit	Ea

The information above is provided as a general recommendation and should not be used as a substitute for information provided by your local State or Territory Work Health & Safety regulatory authority.



National Workplace Burns First Aid Kits

- Contains legislated required set of first aid treatment products plus additional range of hydrogel products and dressings
- Large full colour Burns Treatment poster
- Wallmount case dimensions: 400mm(W) x 480mm(H) x 190mm(D)
- Portable case dimensions: 500mm(W) x 300mm(H) x 300mm (D)



CODE	DESCRIPTION	UOM
AFK873858	Large Wallmount ABS Plastic Case	Ea
AFK873859	Large Portable Soft Case	Ea
AFR873860	Refill Contents Only	Ea



National Workplace Outdoor and Remote First Aid Kit

- Contains legislated required set of first aid treatment products plus additional sting relief, wind-up torch and SOS ground sheet
- Dimensions: 550mm(W) x 300mm(H) x 300mm (D)



CODE	DESCRIPTION	UOM
AFK875494	Large Portable Soft Case	Ea
AFR875495	Refill Contents Only	Ea



Emergency Burns Station

- Provides a specialised first aid unit for areas where there is potential for burns to occur
- Includes a range of hydrogel products for when cool water may not be available
- Tough polypropylene wall mountable case that is easily snapped off to be portable
- Dimensions: 250mm(W) x 200mm(H) x 90mm(D)



CODE	DESCRIPTION	UOM
AFK856591	Emergency Burns Station	Ea



Emergency Eye Wash Station

- Provides a specialised first aid unit for areas where there is potential for eye injuries to occur
- Tough polypropylene wall mountable case that is easily snapped off to be portable
- Dimensions: 250mm(W) x 200mm(H) x 90mm(D)



CODE	DESCRIPTION	UOM
AFK856592	Emergency Eye Wash Station	Ea



Snake Bite First Aid Kit

- For prompt treatment of snake bites
- Kit contains all items required to administer the latest snake bite first aid techniques
- Dimensions: 160mm(W) x 120mm(H) x 60mm(D)



CODE	DESCRIPTION	UOM
AFK856925	Snake Bite Kit	Ea



Sharps Containers

- Stores sharps safely until disposal can occur
- Comes with hazard warning on label
- Range of sizes available



CODE	DESCRIPTION	UOM
AFX853122	Sharps Container - 100ml	Ea
AFX873524	Sharps Container - 200ml	Ea
AFX853125	Sharps Container - 4.5L	Ea
AFX856608	Sharps Container - 1.4L	Ea



First Aid Signs

- Polypropylene signs (450mm x 600mm) for first aid and location requirements
- Polypropylene directional signs (300mm x 125mm) for first aid and evacuation requirements



SSP841532



SSP841566



SSP841568



SSP832185



SSP840000



SSP835324



first aid works

5 MODULE KIT
250+ ITEMS



T3 Workplace Guide:
Low Risk Workplace with up to 50 staff, High Risk Workplace with up to 25 staff.

T3 First Aid Modular Content Kits

- Ideal for large workplaces, work & trade vehicles, factories, farms, sporting clubs, restaurants etc.
- Innovative and easy to use modular system
- Colour coded modules for easy identification
- Available in either a tough toolbox with wall mount bracket or portable soft case
- Comprehensive checklist included
- Toolbox dimensions (hardcase): 420 (W) x 320 (H) x 150 (D)

CODE	DESCRIPTION	UOM
AFKT3MH	T3 Modular Hard Case	Ea
AFKT3MS	T3 Modular Soft Case	Ea
AFRMBM	Burn Module	Ea
AFRMHM	Haemorrhage Module	Ea
AFRMEM	Eye Module	Ea
AFRMMWM	Minor Wound Module	Ea
AFRMAM	Additional Stock Module	Ea



first aid works

4 MODULE KIT
150+ ITEMS



T2 Workplace Guide:
Low Risk Workplace with up to 25 staff, High Risk Workplace with up to 10 staff.

T2 First Aid Modular Content Kits

- Ideal for medium workplaces, work & trade vehicles, etc.
- Innovative and easy to use modular system
- Available in either a tough toolbox with wall mount bracket or portable soft case
- Comprehensive maintenance checklist included
- Toolbox dimensions (hardcase): 340 (W) x 260 (H) x 150 (D)

CODE	DESCRIPTION	UOM
AFKT2UMH	T2 Ultimate Modular Hard Case	Ea
AFKT2UMS	T2 Ultimate Modular Soft Case	Ea
AFRT2MBM	T2 Minor Burn Module	Ea
AFRT2MEM	T2 Eye Module	Ea
AFRT2MHM	T2 Haemorrhage Module	Ea
AFRT2MMWM	T2 Minor Wound Module	Ea



Germ Buster® Anti-bacterial Sanitising Hand Gel

- 70% ethanol v/v
- Kills 99.9% of germs on contact
- Designed to help prevent the spread of germs
- Sustainably sourced bio-ethanol



JHGB0060CL JHGB0100 JHGB0150 JHGB0350



JHCZDA1S



JHGB1000 JHGB5000 JHGB1000C

CODE	DESCRIPTION	UOM
JHGB0060CL	Germ Buster Gel Tottle & Karabiner - 60ml	Ea
JHGB0100	Germ Buster Gel Bottle - 100ml	Ea
JHGB0150	Germ Buster Gel Tube - 150ml	Ea
JHGB0350	Germ Buster Gel Pump - 350ml	Ea
JHGB1000	Germ Buster Gel Pump - 1L	Ea
JHGB5000	Germ Buster Gel Pump - 5L	Ea
JHGB1000C	Germ Buster Dispenser Cartridge - 1L	Ea
JHCZDA1S	Automatic Dispenser With Stop Sign	Ea
ASZWB002	Wall Bracket Suits 1L Pump Pack	Ea



First Aid Room Equipment

A first aid room should be established at the workplace if a risk assessment indicates that it would be difficult to administer appropriate first aid unless a first aid room is provided.



The contents of a first aid room should suit the hazards that are specific to the workplace. **Ask us for a first aid room checklist.**



Powerheart® G5 Automatic Defibrillator

- Fully automatic, simple and easy to use - no buttons
- Audible/text prompts to guide user through CPR
- Comprehensive automatic self-testing programmes
- Lithium battery - 4 year warranty (5 year shelf)
- 90 minutes USB access internal rescue data
- 7 year AED warranty
- Includes 1 pair of defibrillation electrodes & training DVD



AEDZ001A CARRY CASE



AEDG5A31A



CODE	DESCRIPTION	UOM
AEDG5A31A	Powerheart G5 Defibrillator	Ea
AEDZ001A	Premium Carry Case for Powerheart G5	Ea



Precision+ Workplace Breathalyser

- Fuel cell breathalyser
- Accurate 3 decimal place reading
- Passive and Normal mode testing
- Clear on-screen instructions
- Simple and easy to use
- Australian Standards AS 3547



CODE	DESCRIPTION	UOM
AWBPP	Precision+ c/w 100 Mouthpieces	Ea
AWBXPAMP	Mouthpieces	Pk/100



Prodigy S Workplace Breathalyser

- Fuel cell breathalyser
- Accurate 3 decimal place reading
- Passive and Normal mode testing
- Clean air test for increased accuracy
- Touch screen data input
- 15 customisable fields
- Internal storage, PC data link capabilities
- Australian Standards AS 3547



CODE	DESCRIPTION	UOM
AWBPS	Prodigy S c/w 100 Mouthpieces	Ea
AWBXPAMP	Mouthpieces	Pk/100

AlcoSense®

Stealth Personal Breathalyser

- Professional fuel cell breathalyser
- Accurate 3 decimal place reading
- Hard carrying case
- Fast warm up
- Australian Standards AS 3547



CODE	DESCRIPTION	UOM
APBS	Stealth c/w 50 Mouthpieces	Ea
APBXSMP	Mouthpieces	Pk/50

AlcoSense®

Soberpoint 3 Lite Wall Mount Breathalyser

- Designed for mass testing
- LCD display
- Accurate 3 decimal place reading
- Unlimited tests - calibration every 6 months
- Replaceable sensor
- Dimensions: 33cm (H) x 25.5cm (W) x 9cm (D)
- 1 year warranty
- Australian Standards AS 3547



CODE	DESCRIPTION	UOM
AWBS3	Soberpoint 3 Lite c/w LCD	Ea
AWBXSTR1000	Regular Straws	Ctn/1000

DrugSense®

DS08 Saliva Drug Testing Kit

- Detects 7 drugs of abuse + alcohol
- Fast and easy one-step test
- Tests for the parent THC
- Easy-to-read results within 5 minutes
- Non-invasive



CODE	DESCRIPTION	UOM
AWDTDS08	DrugSense DS08 Saliva Drug Test Kit	Ea

DrugSense®

SureStep Urine Drug Testing Cup

- Australian Standards AS 4308
- Detects 7 or 11 drugs of abuse
- Built-in adulteration strip
- Long shelf life
- Collection and results in one cup
- Easy-to-read results within 5 minutes



CODE	DESCRIPTION	UOM
AWDTDSU7	DrugSense SureStep DSU7 Urine Drug Test Cup	Ea
AWDTDSU11	DrugSense SureStep DSU11 Urine Drug Test Cup	Ea

THORZT

99% Sugar Free SOLO SHOT Electrolyte Drink - Mixed Flavours

- 99% sugar free
- Gluten & caffeine free
- Proprietary electrolyte formula including magnesium
- Proprietary blend of B and C group vitamins, L-Glutamine and essential Branch Chain Amino Acids (BCAA's)
- Hypotonic
- 5 flavours in a pack
- 3gm sachet makes 600ml when mixed with water



CODE	DESCRIPTION	UOM
MEDSSF50:MX	Mixed Flavour Pack (10 of each flavour)	Pk/50

THORZT

99% Sugar Free SOLO SHOT Electrolyte Drink - Vend Ready Pack

- 99% sugar free, gluten & caffeine free
- Proprietary electrolyte formula including magnesium
- Proprietary blend of B and C group vitamins, L-Glutamine and essential Branch Chain Amino Acids (BCAA's)
- Portion control distribution
- 5 x 3g/600ml sachets, mixed flavours



CODE	DESCRIPTION	UOM
MEDVP5	Lemon/Lime, Orange, Wildberry, Tropical, Blue Lemonade, Mixed	Pk/5

THORZT

SHOT LOAD Liquid Concentrate Electrolyte Drink Mix

- Low in sugar
- Gluten & caffeine free
- Proprietary electrolyte formula including magnesium
- Proprietary blend of B and C group vitamins, L-Glutamine and essential Branch Chain Amino Acids (BCAA's)
- Hypotonic
- 5 flavours
- 600ml bottle makes 10L when mixed with water



CODE	DESCRIPTION	UOM
MEDLC10	Lemon/Lime, Orange, Wildberry, Iced Tea, Pineapple	Ea
MEDLCMX	Mixed Flavour Carton	Ctn/10
MDXLPD	Liquid Pump Dispenser	Ea

THORZT

Drink Bottles

- Plastic - BPA free
- Stainless steel - food grade 18/8



CODE	DESCRIPTION	COLOURS	UOM
MDXTB800	800ml Plastic Bottle	Silver	Ea
MDXTB750	750ml Stainless Steel Bottle	Black, Blue, Silver	Ea

THORZT

99% Sugar Free SOLO SHOT Electrolyte Drink

- 99% sugar free
- Gluten & caffeine free
- Proprietary electrolyte formula including magnesium
- Proprietary blend of B and C group vitamins, L-Glutamine and essential Branch Chain Amino Acids (BCAA's)
- Hypotonic
- 5 flavours available
- 3gm sachet makes 600ml when mixed with water



CODE	DESCRIPTION	UOM
MEDSSF50	Lemon/Lime, Orange, Wildberry, Tropical, Blue Lemonade	Pk/50
MEDSFMXBT	Tradies Drink Bottle Combo (5 mixed sachets + 800ml drink bottle)	Ea

THORZT

ICE SHOT Electrolyte Icy Pole Pack

- Low in sugar
- Gluten & caffeine free
- Proprietary electrolyte formula including magnesium
- Proprietary blend of B and C group vitamins, L-Glutamine and essential Branch Chain Amino Acids (BCAA's)
- Hypotonic
- When frozen, simply snap and twist to break in half
- 5 flavour mixed pack



CODE	DESCRIPTION	UOM
MEDICEMIX	10 x 90ml Tubes (Lemon/Lime, Orange, Wildberry, Tropical, Blue Lemonade - 2 tubes of each flavour)	Pk/10

THORZT

Drink Cooler Range

- Robust designs with impact resistant exteriors
- Superior insulation to maintain coolness
- Screw top lids for ease of cleaning/filling with ice
- BPA free



MDXTC025

MDXTC05



MDXTC10

MDXTC20

MDXTC55

CODE	DESCRIPTION	COLOURS	UOM
MDXTC025	2.5L Cooler	Blue	Ea
MDXTC05	5L Cooler	Blue, HI VIS Orange	Ea
MDXTC10	10L Cooler	Blue	Ea
MDXTC20	20L Cooler	Blue	Ea
MDXTC55	55L Cooler	Blue	Ea



Electrolyte 2L Liquid Concentrate

- Low sodium, caffeine free, gluten free
- Great taste for increased fluid consumption
- One 2L bottle mixes to 20L of Squincher, convenient to use for larger groups and in 20L coolers
- Flavours: Lemon Lime, Orange, Wildberry, Tropical Cooler, Grape and Lemonade



CODE	DESCRIPTION	UOM
MED2000	Squincher Concentrate 2L - Makes 20L	Ea



Electrolyte Fast Pack

- Fits in your pocket for an on-the-go drink, ideal for mobile workers
- Drink straight from the pack, simply add water
- Convenient single serve packaging for portion control
- Low sodium, caffeine free, gluten free
- Each pack makes 180ml of Squincher
- Flavours: Orange, Tropical Cooler, Wildberry, Lemon Lime



CODE	DESCRIPTION	UOM
MED0018	Squincher Fast Pack 18ml - Makes 180ml	Pk/50



Electrolyte Sugar Free Qwik Stiks

- Sugar free for zero calories
- Convenient single serve packaging for portion control and on-the-go use
- Great taste for increased fluid consumption
- Low sodium, caffeine free, gluten free
- Mix one Qwik Stik with 600ml of water
- Flavours: Orange, Mixed Berry, Lemonade, Grape, Lemon Lime, Cool Citrus and Mixed Flavours



CODE	DESCRIPTION	UOM
MED0100	Squincher Lite Qwik Stiks 3gm - Makes 600ml	Pk/50



Electrolyte Freezeable Squeeze® Pops

- Freezeable format helps cool down core body temperature fast
- Convenient single serve packaging
- Low sodium, caffeine free, gluten free
- Great taste for increased fluid consumption
- Flavours: Mixed Flavours (Orange, Mixed Berry, Lemon Lime, Cherry and Grape)
- Sugar Free option available in Fruit Punch and Tangerine Orange flavours



CODE	DESCRIPTION	FLAVOURS	UOM
MED0159MX	Squeeze® Pops	Mixed	Pk/10
MED0159	Squeeze® Pops Sugar Free	Fruit Punch, Tangerine Orange	Pk/10



Sun Protection Multi-Band

- Multiple style and usage configurations; headband, mask, balaclava, skull cap etc.
- Fast drying fabric
- Stretchable, comfortable and seam free
- Blocks wind, sun and dust
- Flame resistant option available
- Colours: HI VIS Lime, HI VIS Orange, FR Navy



CODE	DESCRIPTION	UOM
HM6485	Ergodyne Multi-Band	Ea
HM6486FR	Ergodyne Multi-Band FR	Ea



Drink Cooler

- 20 litre cooler
- All BPA-free plastic construction with replaceable tap and lid
- Keeps fluid cool for hours
- HI VIS yellow colour with added UV inhibitors to prevent fading



CODE	DESCRIPTION	UOM
MDX20	Squincher Cooler - 20L	Ea



Cooling Wrap Tie

- Tie closure headband
- Lightweight, cooling acrylic polymers
- Soak in cold water for 2-5 minutes to activate
- Remains cool for up to 4 hours
- Colours: Blue, HI VIS Lime, Red Western, Navy Western, Camouflage



CODE	DESCRIPTION	UOM
HM6700	Ergodyne Cooling Wrap Tie	Ea



Hydration Packs

Nuke HI VIS

- Industrial grade backpack c/w premium 3 litre Source™ hydration reservoir and reflective tape

Stinger HI VIS

- 2L slim line twin compartment design - HI VIS reflective Day/Night tape



CHB6324

CHB6330

CODE	DESCRIPTION	COLOURS	UOM
CHB6324	Nuke HI VIS 3 Litre	Yellow, Orange	Ea
CHB6330	Stinger HI VIS 2 Litre	Yellow, Orange	Ea



Natural Citrus Scrub Hand Cleaner

- Childcare friendly
- Removes and dissolves dirt, grease & oil, ink & glue, soil
- Natural moisturising oils
- Citrus scent



CODE	DESCRIPTION	UOM
JHCCSB05	Ultra Clean Hands Natural Citrus Scrub Cleaner 500ml*	Ea
JHCCSB1C	Ultra Clean Hands Natural Citrus Scrub Cleaner 1L*	Ea
JHCCSB5	Ultra Clean Hands Natural Citrus Scrub Cleaner 5L*	Ea
JHCCSB15	Ultra Clean Hands Natural Citrus Scrub Cleaner 15L*	Ea



Pumice Grit Hand Cleaner

- Deep scrubbing pumice
- Removes carbon black, metal dust, stubborn grease and oils
- Lanolin & Vitamin E
- Citrus scent



CODE	DESCRIPTION	UOM
JHCPGT05	Ultra Clean Hands Pumice Grit Hand Cleaner 500ml*	Ea
JHCPGT1C	Ultra Clean Hands Pumice Grit Hand Cleaner 1L*	Ea
JHCPGT5	Ultra Clean Hands Pumice Grit Hand Cleaner 5L*	Ea
JHCPGT15	Ultra Clean Hands Pumice Grit Hand Cleaner 15L*	Ea



Heavy Duty Hand Cleaner

- Gentle scrubbing beads
- Removes and dissolves paint & resins, industrial ink, body filler, adhesives
- Lanolin moisturiser
- Great for spray painters



CODE	DESCRIPTION	UOM
JHCHD05	Ultra Clean Hands Heavy Duty Hand Cleaner 500ml*	Ea
JHCHD1C	Ultra Clean Hands Heavy Duty Hand Cleaner 1L*	Ea
JHCHD5	Ultra Clean Hands Heavy Duty Hand Cleaner 5L*	Ea
JHCHD15	Ultra Clean Hands Heavy Duty Hand Cleaner 15L*	Ea



Washroom Hand Washes

Antibacterial Foam Wash

- Antibacterial: kills 99.9% of germs
- Low irritant with added moisturisers
- Biodegradable
- 100% plant based surfactants



Hand & Body Wash

- 100% plant based surfactants
- SLS and phosphate free
- Moisturising
- Biodegradable
- Septic and Grey Water safe



CODE	DESCRIPTION	UOM
JHCAFW300	Antibacterial Foam Wash - 300ml Pump*	Ea
JHCAFW1	Antibacterial Foam Wash - 1L Cartridge*	Ea
JHCAFW5	Antibacterial Foam Wash - 5L Bottle*	Ea
JHCHBW500P	Hand & Body Wash - 500ml Pump*	Ea
JHCHBW1	Hand & Body Wash - 1L Cartridge*	Ea
JHCHBW5	Hand & Body Wash - 5L Bottle*	Ea



Dispenser Units

- Manual or automatic dispenser options
- Suit 1L cartridge style containers
- Drip tray included



JHCZDM1
WHITE

JHCZDM1
BLACK

JHCZDA1

CODE	DESCRIPTION	COLOURS	UOM
JHCZDM1	Manual Dispenser	White, Black	Ea
JHCZDA1	Automatic Dispenser	White	Ea



Wall Brackets

- Wall mountable brackets
- White powder coat
- 3 size options

CODE	DESCRIPTION	UOM
ASZWB003	Bracket to suit 500ml Pump	Ea
ASZWB002	Bracket to suit 1L Pump	Ea
ASZWB001	Bracket to suit 2.5L Pump	Ea





ProBloc Sunscreen SPF50+ Lotions

- SPF 50+ provides ultra-broad-spectrum protection from the sun's harsh UVA and UVB rays
- 4 hours water resistant - perfect for worksite use
- Contain Vitamin E and Aloe Vera to moisturise and condition the skin
- Featuring dry touch technology for a light natural skin feel
- Skin friendly dermatologically tested formula
- Developed and manufactured in Australia
- Complies with AS/NZS 2604:2012



CODE	DESCRIPTION	UOM
ASSZST12-50	ProBloc SPF50+ Zinc Stick Tan - 12gm*	Ea
ASSS60C-50	ProBloc SPF50+ Squeeze Bottle with Carabiner - 60ml*	Ea
ASSS125-50	ProBloc SPF50+ Tube - 125ml*	Ea
ASSS250-50	ProBloc SPF50+ Flip Top Bottle - 250ml*	Ea
ASSS500-50	ProBloc SPF50+ Pump Bottle - 500ml*	Ea
ASSS1-50	ProBloc SPF50+ Pump Bottle - 1L*	Ea
ASSS2500-50	ProBloc SPF50+ Pump Bottle - 2.5L*	Ea



Sunscreen SPF30 Lotion with Insect Repellent

- SPF30 protection
- Broad spectrum UVA & UVB rays
- 2 hours water resistant
- Tropical strength
- TGA and APVMA listed
- Complies with AS/NZS 2604:2012



CODE	DESCRIPTION	UOM
ASUP125IR	Sunscreen SPF30 With Insect Repellent - 125ml Flip Top*	Ea
ASUP1000IR	Sunscreen SPF30 With Insect Repellent - 1L Pump*	Ea



Ultra Protect Sunscreen SPF50+ Lotions

- Very high SPF50+ protection
- Broad spectrum protection from UVA & UVB rays
- Nanoparticle free
- 4hrs water resistant
- Low irritant
- Fragrance free
- Dry touch - non stick
- Contains Vitamin E and Aloe Vera for moisturising and conditioning the skin
- Rubs in clear
- TGA Listed AUSTL 144581
- Complies with AS/NZS 2604:2012



CODE	DESCRIPTION	UOM
ASUP5010	Ultra Protect SPF50+ Sachet - 10ml*	Ea
ASUP5012	Ultra Protect SPF50+ Sunstick Lip Balm - 12gm*	Ea
ASUP5060	Ultra Protect SPF50+ Clip-on Tottle - 60gm*	Ea
ASUP5100	Ultra Protect SPF50+ Tube - 100gm*	Ea
ASUP5250	Ultra Protect SPF50+ Flip Top Bottle - 250ml*	Ea
ASUP5250S	Ultra Protect SPF50+ Trigger Spray - 250ml*	Ea
ASUP5500	Ultra Protect SPF50+ Pump Pack - 500ml*	Ea
ASUP51000	Ultra Protect SPF50+ Pump Pack - 1L*	Ea
ASUP52500	Ultra Protect SPF50+ Pump Pack - 2.5L*	Ea
ASUP55000	Ultra Protect SPF50+ Pump Pack - 5L*	Ea



Red-Eyed Gotcha! Insect Repellent

- Tropical strength
- Repels & protects for 6 hours
- Neutral scent, non greasy
- Longer lasting protection against mosquitoes that may carry Malaria, Ross River Virus & Dengue



CODE	DESCRIPTION	UOM
AREG050	Red-Eyed Gotcha! Clip-on - 50ml	Ea
AREG100RO	Red-Eyed Gotcha! Roll-on - 100ml	Ea
AREG100P	Red-Eyed Gotcha! Pump - 100ml	Ea
AREG150A	Red-Eyed Gotcha! Aerosol - 150ml	Ea

*Refer to ingredients and warnings at www.safetyquip.com.au

pro-val

WP Solvent Wipes

- Ideal for applications that involve grease, oil, diesel and dirt
- Can absorb more than 7x their own weight
- Made from woodpulp and polyester fibres
- Low lint
- Excellent strength



CODE	DESCRIPTION	UOM
JDW40510	WP Solvent Wipes 35 x 30cm - Dispenser Style	Bag/50
JDW40511	WP Solvent Wipes 29 x 40cm - Perforated Roll	Roll/500

pro-val

VC600 Cleaning Wipes

- Extremely low lint
- Used wet or dry
- Ideal for a wide range of applications
- Exceptional strength, durability and absorbency
- Made from non-woven fibre, spun laced with 90% viscose/10% polyester



CODE	DESCRIPTION	COLOUR	UOM
JDW600	VC600 Wipes 32 x 60cm - Sheet Style	White	Pk/50

pro-val

HD Heavy Duty Wipes

- Ideal for food, hospitality and general cleaning
- Heavy duty cross lapped mesh wipe - 60gms
- HACCP Australia Food Safety Certification
- Excellent strength
- Colour options



CODE	DESCRIPTION	COLOURS	UOM
JDW40518	HD Wipes 30 x 45cm - Roll Style	Blue, Green	Roll/100

De-Solv-it

De-Solv-it Multi-Purpose Cleaner

- Highly effective citrus based solvent for many degreasing, dewaxing and adhesive removal tasks
- Much safer than traditional hydrocarbon solvents - not a Class 3 Flammable
- No overwhelming vapours
- Biodegradable
- SDS available



CODE	DESCRIPTION	UOM
JCS003W	De-Solv-it Cleaner - 300ml	Ea
JCS0075W	De-Solv-it Cleaner - 750ml	Ea
JCS04W	De-Solv-it Cleaner - 4L	Ea
JCS20W	De-Solv-it Cleaner - 20L	Ea

Ultra Clean Washrooms



Lemon Disinfectant

- Commercial grade
- Kills germs and bacteria
- Fresh Lemon Zest fragranced
- Removes fats, oils, greases and general dirt & grime



CODE	DESCRIPTION	UOM
JCLD5	Ultra Clean Lemon Disinfectant - 5L*	Ea
JCLD15	Ultra Clean Lemon Disinfectant - 15L*	Ea

Ultra Clean Washrooms



Floor Cleaner

- Concentrated industrial performance
- Fast drying
- Suitable for everyday use on floors and hard surfaces



CODE	DESCRIPTION	UOM
JCFC5	Ultra Clean Floor Cleaner - 5L*	Ea
JCFC15	Ultra Clean Floor Cleaner - 15L*	Ea

Ultra Clean Washrooms



Glass & Window Cleaner

- Glass, window and mirror cleaner
- Fast drying, non-staining
- Streak free sparkling finish



CODE	DESCRIPTION	UOM
JCGC750	Ultra Clean Glass Cleaner - 750ml*	Ea
JCGC5	Ultra Clean Glass Cleaner - 5L*	Ea

Ultra Clean Washrooms



Multi Surface Spray & Wipe Surface Cleaner

- Anti-bacterial multi-purpose surface cleaner
- Safe on both hard and soft surfaces
- Pleasant scent



CODE	DESCRIPTION	UOM
JCSC750	Ultra Clean Spray & Wipe Surface Cleaner - 750ml*	Ea
JCSC5	Ultra Clean Spray & Wipe Surface Cleaner - 5L*	Ea

Ultra Clean Washrooms



Toilet & Urinal Perfumed Blocks

- Compressed perfumed toilet blocks
- Economical long term odour control
- Tropical fragrance



CODE	DESCRIPTION	UOM
JCTB4	Ultra Clean Blockettes Perfumed Toilet Blocks - 4kg*	Ea
JCTB10	Ultra Clean Blockettes Perfumed Toilet Blocks - 10kg*	Ea
JCTB15	Ultra Clean Blockettes Perfumed Toilet Blocks - 15kg*	Ea

*Refer to ingredients and warnings at www.safetyquip.com.au



SITE SAFETY

APPLICATION

Workplaces under the heading 'Site Safety' are bound by legislative requirements in the disciplines of traffic management, management of hazardous/flammable storage, fire protection, onsite electricity, gas/flammable fuels and water, machinery safety, height safety and environmental protection. This section has the necessary product range that will assist with the 'safe place of work' and 'safe system of work' obligations of statute law.

RISK ASSESSMENT

The Safe Work Australia Code of Practice 'Managing the Work Environment & Facilities' provides guidelines that address typical issues relating to Site Safety.

Signage

Safety signage is as essential element in any workplace. Signs are identified in categories - Mandatory, Prohibition, Danger, Warning, Emergency, Fire and general site safety signage. The Australian Standard AS 1319 sets out the requirements for the design and use of safety signs.

Traffic & Pedestrian Control

The movement of traffic in and around workplaces including road works warrants particular care due to the high risks involved. The Australian Standard AS 1743-2001 'Road Signs Specifications' provides details of layout, graphics, size and material requirements.

Spill Control & Flammable Storage

Workplaces must be prepared for the management & storage control of hazardous materials with the capacity to reduce the chance of a spill spreading or a fire being caused and/or becoming worse. AS 1940-2004 sets out the requirements and recommendations for the safe storage and handling of flammable liquids.

Lockout/Tagout

A Lockout/Tagout programme includes the use of specific devices and tags to prevent accidental activation of equipment during maintenance, installation or inspection. Each confined space entry should have its own set of written lockout procedures and be appropriately supervised.

Ladders & Platforms

Falling from ladders is the cause of at least half of all falls from height injuries. Do not use ladders in the workplace before first seeking education and advice then ensuring that all ladder users are educated and authorised. AS 1892 sets out the design requirements for portable ladders and sets out the minimum requirements for selection, safe use and care.

Emergency Eye Wash & Shower Equipment

When workers' bodies have the potential to be exposed to materials or chemicals which may cause injuries, access to

appropriate eyewash and shower equipment for emergency treatment should be available. AS 4775-2007 specifies minimum performance and use requirements for eyewash and shower equipment for the emergency treatment.



USEFUL REFERENCES

Safe Work Australia Code of Practice 'Managing the Work Environment & Facilities'.

AS 1319-1994 Safety signs for the occupational environment.

AS 1743-2001 Road sign specifications.

AS 1940-2004 The storage and handling of flammable combustible liquids.

AS 1892.5 Portable ladders - Selection, safe use and care.

AS 4775-2007 Emergency eye wash and shower equipment.

SIGNAGE	112
TRAFFIC & PEDESTRIAN CONTROL	114
LIGHTING	118
MIRRORS	121
SPILL CONTROL	122
FLAMMABLE/CYLINDER STORAGE	125
ELECTRICAL	129
FIRE EXTINGUISHERS	130
EYE/FACE WASH & SHOWERS	132
LOCKOUT/TAGOUT	134
LADDERS/PLATFORMS	136
TAPES & FLOOR MARKING	138
MATTING	139
AIR HORNS	140

BRADY

Mandatory Signs 600mm x 450mm

- 0.6mm Colorbond™ steel or 1.4mm polypropylene
- Suitable for outdoor conditions
- Compliant to AS 1319:1994
- Other sizes available



SSP835014
SSM838192

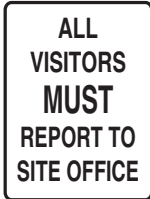

SSP844553
SSM842144



SSP835010
SSM832119



SSP835024
SSM832204



SSP835020
SSM832142



SSP835043
SSM832139



SSP835004
SSM832114



SSP835037
SSM832129



SSP835884
SSM840357



SSP869726
SSM832435



SSP835012
SSM832132



SSP835032
SSM834028



SSP835022
SSM832145



SSP835016
SSM834751



SSP852623
SSM852624



SSP841029
SSM838790

CODE	DESCRIPTION
SSP...	Mandatory Signs - Poly 600mm x 450mm
SSM...	Mandatory Signs - Metal 600mm x 450mm

BRADY

Danger Signs 450mm x 600mm

- 0.6mm Colorbond™ steel or 1.4mm polypropylene
- Suitable for outdoor conditions
- Compliant to AS 1319:1994
- Other sizes available



SSP835272
SSM841801



SSP844510
SSM832438



SSP835279
SSM834608



SSP835818
SSM840450



SSP835301
SSM841773



SSP835274
SSM841805



SSP835789
SSM840875



SSP840879
SSM840880



SSP854902
SSM832446



SSP842254
SSM832479



SSP842162
SSM832424



SSP840907
SSM840908

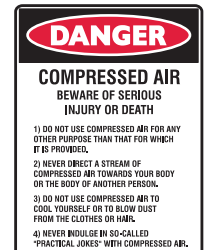

SSP835138
SSM834033



SSP840733
SSM840734



SSP842241
SSM840249

CODE	DESCRIPTION
SSP...	Danger Signs - Poly 450mm x 600mm
SSM...	Danger Signs - Metal 450mm x 600mm

BRADY

Emergency Exit & Evacuation Signage



450MM X 600MM
SSP835365 (POLY)
SSM832491 (METAL)

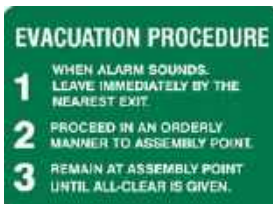

300MM X 450MM
SSP835335 (POLY)
SSM841530 (METAL)

- 0.6mm Colorbond™ steel or UV stable 1.4mm polypropylene



SSV851516



SSV851515



SSV851513



SSV851517



SSV851514



SSV851518



SSV877250



SSV877243

- Luminous vinyl adhesive for indoor use, 180mm x 450mm



SSP832736



SSP832720



SSP832704



SSP832706

- UV stable 1.4mm polypropylene, 180mm x 350mm



Warning Signs 600mm x 450mm

- 0.6mm Colorbond™ steel or 1.4mm polypropylene
- Suitable for outdoor conditions
- Compliant to AS 1319:1994
- Other sizes available



SSP835387
SSM832455



Prohibition Signs 600mm x 450mm

- 0.6mm Colorbond™ steel or 1.4mm polypropylene
- Suitable for outdoor conditions
- Compliant to AS 1319:1994
- Other sizes available



SSP835186
SSM832312



SSP841744
SSM841745



SSP841389
SSM841390



SSP844439
SSM844440



SSP833884
SSM833859



SSP833886
SSM832082



SSP835773
SSM832537



SSP835805
SSM840605



SSP841647
SSM841648



SSP840642
SSM832561



SSP835385
SSM832456



SSP835103
SSM832293



SSP841381
SSM841382



SSP835190
SSM832330



SSP841142
SSM834630



SSP835227
SSM832348



SSP835223
SSM840204



SSP835188
SSM832324



SSP835253
SSM834733



SSP835196
SSM832170



SSP835255
SSM840222



SSP835201
SSM834010



SSP835192
SSM832167



SSP835199
SSM832180



SSP835644
450MM X 600MM

CODE	DESCRIPTION
SSP...	Warning Signs - Poly 600mm x 450mm
SSM...	Warning Signs - Metal 600mm x 450mm

CODE	DESCRIPTION
SSP...	Prohibition Signs - Poly 600mm x 450mm
SSM...	Prohibition Signs - Metal 600mm x 450mm



Custom Multiple Condition Signs

- 0.6mm Colorbond™ steel signs
- 200mm diameter self-adhesive pictograms
- Suitable for outdoor conditions
- Compliant to AS 1319:1994
- Other materials and sizes available

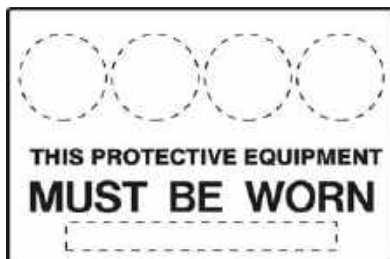

CODE	DESCRIPTION
SSM...	Multiple Condition Signs - Metal 600mm x 900mm
SSV...	Multiple Condition Pictograms - Self Adhesive 200mm Diameter



Standard Multiple Condition Sign



SSM846123

Select from template options and pictograms pictured left: "Must be worn..."
SSM832103 - In This Area
SSM832109 - Beyond This Point
SSM832152 - Within This Facility
SSM834596 - On This Site



Multi Message Frame & Signs

- Sturdy multi message frame with optional fixed or folding bipod legs sold separately
- Corflute Class 1 reflective signage
- Wide range of signage messages available in 300mm x 1200mm, 600mm x 600mm and 600mm x 1200mm

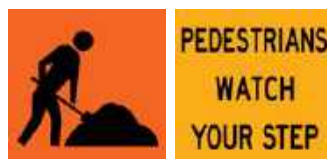
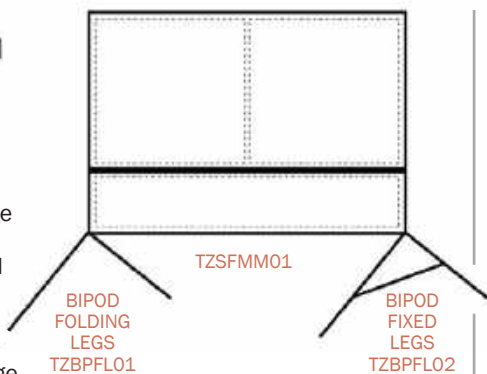

CODE	DESCRIPTION	DIMENSIONS
TZSFMM01	Multi Message Frame	900mm x 1200mm
TZBPFL01	Multi Message Bipod Folding Legs	-
TZBPFL02	Multi Message Bipod Fixed Legs	-
TZSMMT935	Corflute Sign - '50'	
TZSMMT936	Corflute Sign - '60'	
TZSMMT927	Corflute Sign - 'Roadwork Ahead'	600mm x 600mm
TZSMMT926	Corflute Sign - 'End Roadwork'	
TZSMMT930	Corflute Sign - Symbolic 'Workmen Ahead'	
TZSMMT925	Corflute Sign - 'Pedestrians Watch Your Step'	
TZSMMT910	Corflute Sign - 'Roadwork Ahead'	
TZSMMT99	Corflute Sign - 'End Roadwork'	
TZSMMT950	Corflute Sign - 'Reduce Speed'	300mm x 1200mm
TZSMMT922	Corflute Sign - 'Prepare To Stop'	
TZSMMT918	Corflute Sign - '← Pedestrians'	
TZSMMT919	Corflute Sign - 'Pedestrians →'	



Traffic Control Stop/Slow Batons

- Wooden or extendable aluminium handle
- Compliance to Australian Standards for Class 1 Reflective
- Size options of 450mm or 600mm



CODE	DESCRIPTION	UOM
TZSSW450C1	Stop/Slow Baton C1 Wooden Handle - 450mm	Ea
TZSSA450C1	Stop/Slow Baton C1 Aluminium Handle - 450mm	Ea
TZSSW600C1	Stop/Slow Baton C1 Wooden Handle - 600mm	Ea



Swing Signs

- Metal swing signs
- Size: 600mm x 900mm
- Signs available separately
- Full range of traffic control messages available
- Galvanised 'A' frame swing stand
- Compliance to Australian Standards for Class 1 Reflective



CODE	DESCRIPTION	DIM.
TZSWS516	Swing Sign & Stand - Symbolic 'Workmen Ahead'	
TZSWS500	Swing Sign & Stand - 'Roadwork Ahead'	
TZSWS502	Swing Sign & Stand - 'Road Closed'	
TZSWS517	Swing Sign & Stand - Symbolic 'Stop/Slow' Controller	
TZSWS506	Swing Sign & Stand - 'Detour Ahead'	
TZSWS511	Swing Sign & Stand - Pictograph 'Truck'	
TZSWS503	Swing Sign & Stand - 'Pedestrians Watch Your Step'	600mm x 900mm
TZSWS514	Swing Sign & Stand - '← Pedestrians'	
TZSWS515	Swing Sign & Stand - 'Pedestrians →'	
TZSWS210	Swing Sign & Stand - Right Directional Arrow	
TZSWS513	Swing Sign & Stand - 'Footpath Closed'	
TZSWS504	Swing Sign & Stand - 'Use Other Footpath'	
TZSWS508	Swing Sign & Stand - 'Traffic Hazard Ahead'	
TZSWS518	Swing Sign & Stand - 'Prepare To Stop'	
TZSWS507	Swing Sign & Stand - 'Grass Cutting In Progress'	



HI VIS T-Post Bollards

- Manufactured from UV stabilised high quality rubber
- Reflective band on HI VIS orange colour for excellent visibility
- Removable base for ease of storage and transport
- Available with 6kg or 8kg base



CODE	DESCRIPTION	UOM
TBOLL6	1.0m Orange Reflective Bollard 6kg Base	Ea
TBOLL8	1.0m Orange Reflective Bollard 8kg Base	Ea
TSTEM	T-Top HI VIS Bollard Stem 1.0m Height - No Base	Ea
TBASE6	Bollard Base only - 6kg	Ea
TBASE8	Bollard Base only - 8kg	Ea



Traffic Cone Light

- Fits most traffic cones
- 1 x 1 Watt LED, requires three C batteries
- Four flash patterns
- Available in manual On/Off version or with Day/Night function



CODE	DESCRIPTION	COLOURS	UOM
TLC2	Traffic Cone Light - Manual On/Off Version	Amber, Red, Blue, Green, Clear	Ea
TLC2N	Traffic Cone Light - Day/Night Version		Ea



Traffic Cone Extension Bar

- Exterior grade ABS plastic
- Rubberised loops both ends
- Extendable: closed 135cm, extended 210cm
- HI VIS 15cm yellow reflective bands



CODE	DESCRIPTION	UOM
TCBAR	Traffic Cone Extension Bar	Ea



Hi Vis Traffic Cones

- Made from UV stabilised high quality orange PVC
- Stackable for ease of storage and transport
- HI VIS orange colour for excellent daytime visibility

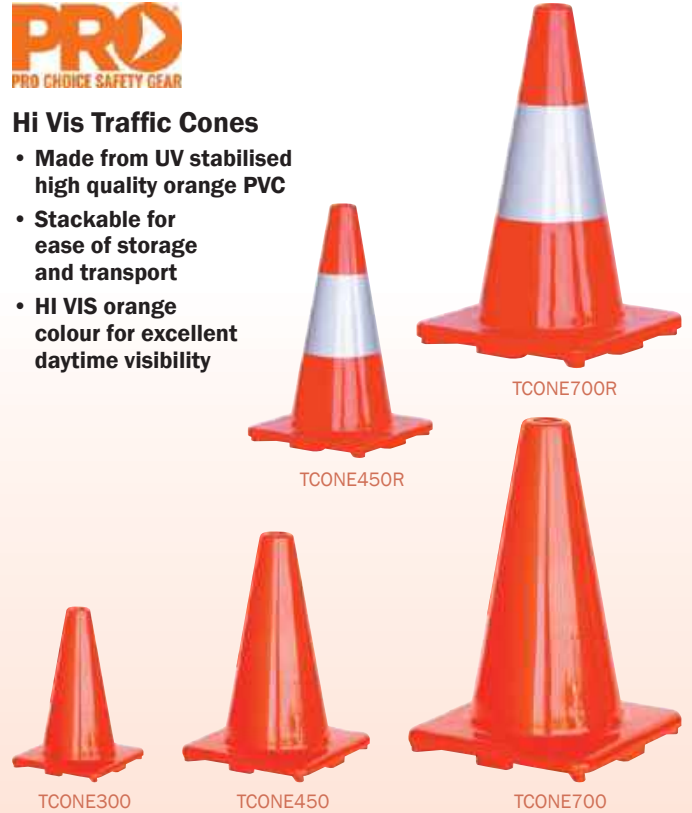

CODE	DESCRIPTION	UOM
TCONE300	300mm Orange Road Cone	Ea
TCONE450	450mm Orange Road Cone	Ea
TCONE700	700mm Orange Road Cone	Ea
TCONE450R	450mm Orange Reflective Road Cone	Ea
TCONE700R	700mm Orange Reflective Road Cone	Ea



Orange Barrier Fencing Mesh

- High quality polypropylene for longer life
- 50m x 1m rolls individually bagged, weight of 8kg per roll
- Manufactured in accordance with AS 1742.3:2002

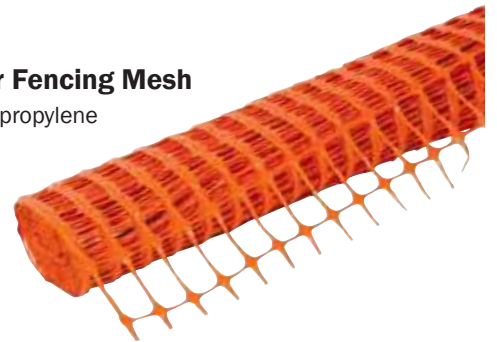

CODE	DESCRIPTION	UOM
TBM8	8kg Orange Mesh 1m x 50m	Roll



Site/Facilities Traffic Management Signs

- Speed limit signage for general site use
- Directional traffic signage for employee and visitor safety
- 600mm x 450mm metal signs shown



SSM834051
(600mm x 600mm)



SSM841876



SSM841878



SSM841848



SSM841855



SSM843212



SSM833969



SSM841852



SSM841872



SSM841850



SSM841846



SSM833970



SSM833971



Fixed Round Bollards

- 1.0m surface mount or below ground bollard options
- Standard Class 1 reflective band c/w caps
- Galvanised and powder coated
- Supplied with fixings for surface mount
- Heavy duty or economy options
- Optional chain ring kit



TBOLLZRK

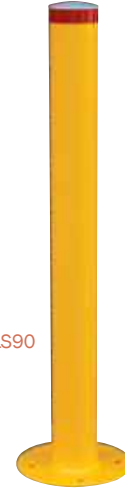

TBOLLS90



TBOLLS90G

CODE	DESCRIPTION	DIMENSIONS	UOM
TBOLLS90	Bollard Surface Mount Heavy Duty	1.0m(H) x 90mm(D) x 5mm(W)	Ea
TBOLLS90G	Bollard Below Ground Heavy Duty	1.0m(H) x 90mm(D) x 5mm(W)	Ea
TBOLLS90E	Bollard Surface Mount Economy	1.0m(H) x 90mm(D) x 3.2mm(W)	Ea
TBOLLS90GE	Bollard Below Ground Economy	1.0m(H) x 90mm(D) x 3.2mm(W)	Ea
TBOLLS140	Bollard Surface Mount Heavy Duty	1.2m(H) x 140mm(D) x 5mm(W)	Ea
TBOLLS140G	Bollard Below Ground Heavy Duty	1.2m(H) x 140mm(D) x 5mm(W)	Ea
TBOLLS140E	Bollard Surface Mount Economy	1.2m(H) x 140mm(D) x 3.5mm(W)	Ea
TBOLLS140GE	Bollard Below Ground Economy	1.2m(H) x 140mm(D) x 3.5mm(W)	Ea
TBOLLZRK	Bollard Chain Ring Kit	-	Ea



Slo-motion Steel Speed Hump

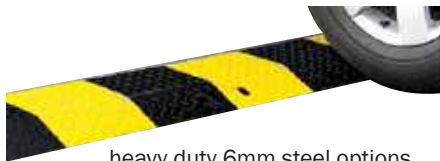

- Standard 3mm or heavy duty 6mm steel options
- 1m or 0.5m modules with choice of rubber or steel end caps
- Designed to comply with AS/NZS 2890.1:2004
- Built-in bridge design to accommodate hoses or cables
- Supplied with all necessary fixings

CODE	DESCRIPTION	COLOUR	UOM
TSHM500S	Speed Hump Standard 3mm - 0.5m Module	Black/ Yellow	Ea
TSHM1000S	Speed Hump Standard 3mm - 1.0m Module		Ea
TSHM500	Speed Hump Heavy Duty 6mm - 0.5m Module		Ea
TSHM1000	Speed Hump Heavy Duty 6mm - 1.0m Module		Ea
TSHR250E	Speed Hump Rubber End Caps - 0.19m	Black	Pr
TSHMECS	Speed Hump Steel End Caps - 0.175m	Yellow	Pr
TSHSKIT	Complete Speed Hump Sign Kit	-	Kit



Slo-Motion Economy Rubber Speed Hump



- Economical recycled and natural rubber
- Built-in bridge cable channel
- 250mm body modules with 190mm rubber end caps
- Complies with AS/NZS 2890.1:2004
- Supplied with all necessary fixings



CODE	DESCRIPTION	COLOUR	UOM
TSHR250Y	Speed Hump Compliance 250mm Body	Yellow	Ea
TSHR250B	Speed Hump Compliance 250mm Body	Black	Ea
TSHR250E	Speed Hump Compliance 190mm End Cap	Black	Pr
TSHSKIT	Complete Speed Hump Sign Kit	-	Kit



Slo-Motion Compliance Speed Hump

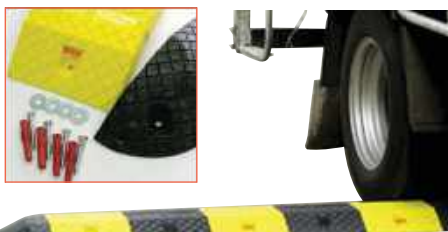

- Heavy duty injection moulded linear low density polyethylene
- 250mm body modules with 180mm rubber end caps
- Built-in bridge cable channel and prismatic reflectors
- Complies with AS/NZS 2890.1:2004
- Supplied with all necessary fixings

CODE	DESCRIPTION	COLOUR	UOM
TSHP250Y	Speed Hump Compliance 250mm Body	Yellow	Ea
TSHP250B	Speed Hump Compliance 250mm Body	Black	Ea
TSHP250E	Speed Hump Compliance 180mm End Cap	Black	Pr
TSHSKIT	Complete Speed Hump Sign Kit	-	Kit



Parking Wheel Stops



- Heavy duty injection moulded linear low density polyethylene or recycled rubber
- Economical and simple to install
- Moulded one-piece designs
- Complies with AS/NZS 2890.1:2004
- Fixing kits sold separately

TWS1650

TWS1700



CODE	DESCRIPTION	COLOURS	UOM
TWS1700	LLDPE Wheel Stop 1.7m(L) x 160mm(W) x 100mm(H)*	Yellow, Blue, Grey	Ea
TWS1650	Rubber Wheel Stop 1.65m(L) x 155mm(W) x 95mm(H)	Black/Yellow	Ea



Wheel Chocks

- Recycled high quality moulded rubber
- Single & double-sided options

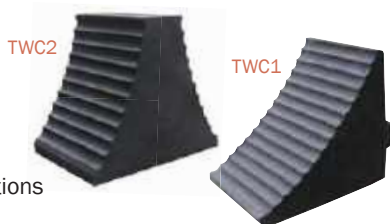

CODE	DESCRIPTION	UOM
TWC1	Wheel Chock Single Side 255mm(L) x 210mm(H) x 180mm(W)	Ea
TWC2	Wheel Chock Double Side 250mm(L) x 220mm(H) x 180mm(W)	Ea
TWC3	Wheel Chock Heavy Duty 305mm(L) x 260mm(H) x 300mm(W)	Ea



Kerb Ramps

- Portable heavy duty moulded rubber ramp
- Recessed mounting holes for securing ramp in place



TKR1030



TKR100E

CODE	DESCRIPTION	UOM
TKR1030	Kerb Ramp Black 110mm(H) x 430mm(D) x 480mm(W)	Ea
TKR100	Kerb Ramp Body HI VIS 100mm(H) x 320mm(D) x 610mm(W)	Ea
TKR100E	Kerb Ramp End Cap HI VIS 100mm(H) x 310mm(D) x 310mm(W)	Ea



Pilot 10m Belt Barrier

- Belt extends to 10m
- Four-way connectivity
- Economical solution
- Pilot body comes complete with braked belt, locking clip, cone mount adaptor and locking wall receiver
- Wall Mount: Permanently fix to any flat surface, supplied with belt wall receiver
- Magnetic Mount: Temporarily attach to any metal surface, built-in safety bungy, supplied with magnetic wall receiver



PILOT SHOWN WITH CONE MOUNT ATTACHMENT (INCLUDED)

CODE	DESCRIPTION	COLOURS	UOM
TBSPIL0T	Pilot with 10m Belt & Cone Mount Adaptor	Black/Yellow, Red/White, Blue, Black, Red, Yellow	Ea

Cone Mount Attachment

- 80mm diameter
- Can be screwed to the cone for greater security



CODE	DESCRIPTION
TBSPIL0TCMA	Cone Mount Attachment

4-Way Receiver

- 60mm diameter
- Allows up to four Pilot belts to be terminated simultaneously



CODE	DESCRIPTION
TBSPIL0T4WR	4-Way Receiver

Wall Mount Bracket

- Can be permanently fixed to any flat surface or to Multi-Post
- Twist-lok feature for quick attachment or removal of the Pilot unit



CODE	DESCRIPTION
TBSPIL0TWMB	Wall Mount Bracket
TBSPIL0TRC	Wall Mount Receiver

Magnetic Mount

- The strong magnet allows temporary placement of the Pilot unit on any steel surface
- Comes with a built-in safety bungy



CODE	DESCRIPTION
TBSPIL0TMMB	Magn.Mount Bracket
TBSPIL0TND	Magn.Mount Receiver



PILOT UNIT NOT INCLUDED

20kg Portable Post & Base

- For outdoor windy locations
- Cast iron base

6.8kg Hi-Line Post & Base

- 1m UPVC traffic post
- Rubber base

CODE	DESCRIPTION
TBSPIL0T20	20kg Portable Post & Base
TBSPIL0THLPCV	6.8kg Hi-Line Post & Base

Solar Powered Flashing Light

- Solar powered, no batteries required
- Off, Flash and Static modes



CODE	DESCRIPTION	COL.
TBSPIL0TLT	Solar Powered Flashing Light	Red, White

Sign Holder

- Compatible with all Pilot Twist-lok receivers
- Clear double-sided acrylic sign pocket



CODE	DESCRIPTION
TBSPIL0TA4	A4 Sign Holder
TBSPIL0TA5	A5 Sign Holder



Retracta-Belt System

Wall Mount

- For wall mount applications
- Belt is quickly deployed or released
- Complete with bracket and receiver clip



TBRWM76

Magna Mount

- Complete with magnetic receiver clip
- Designed for temporary placement - easily relocated
- Semi-permanent, magnetic fixed placement



TBRMM76

CODE	DESCRIPTION	COLOURS	UOM
TBRWM76	Retracta-Belt Wall Mount (1.2kgs) - 7.6m	Red/White, Black/Yellow, Red, Black, Yellow	Ea
TBRMM76	Retracta-Belt Magna Mount (1.5kgs) - 7.6m	Red/White, Black/Yellow	Ea



Port-a-guard Expandable Barrier

- 3.0m or 6.0m kits include freestanding and wall mounted configurations
- Suitable for indoor & outdoor use
- 990mm(H) with 400mm wide feet for increased stability
- Extruded aluminium post and slats with powder coated finish
- Wall receiver and sign brackets included



TBP300

CODE	DESCRIPTION	COLOURS	UOM
TBP300	Port-a-guard Barrier Kit (5.7kgs) - 3.0m	Red/White, Black/Yellow	Ea
TBP600	Port-a-guard Barrier Kit (9.8kgs) - 6.0m	Red/White, Black/Yellow	Ea



Portable Plastic Fence Barrier

- Low cost portable and stackable crowd control barrier
- Interlocking free-standing panels
- Durable polyethylene in HI VIS orange
- Black recycled rubber feet



CODE	DESCRIPTION	COLOURS	UOM
TBF2000	Portable Plastic Fence Barrier (13kgs) - 1.0m(H) x 2.0m(W)	Orange, Yellow	Ea



Mobile Expanding Barrier

- Lightweight and portable crowd control barrier
- Durable polyethylene construction in HI VIS yellow
- Castor wheels & locking straps for ease of handling
- Easy to set up and fold away



CODE	DESCRIPTION	UOM
TBEMTOBY	Expanding Mobile Barrier (16kgs) - 1.0m(H) x 4.0m(W)	Ea



Hazard Barricade Tape

- 50µ medium duty plastic tape
- 75mm wide
- 100 metre rolls



CODE	DESCRIPTION	UOM
ST75BYC	Yellow 'Caution'	100m Roll
ST75BRWD	Red/White Diagonal 'Danger'	100m Roll
ST75BRWDNE	Red/White Diagonal 'Danger Do Not Enter'	100m Roll
ST75BYDAH	Yellow 'Danger Asbestos Hazard'	300m Roll
ST75BBW	Blue/White Diagonal	100m Roll
ST75BGW	Green/White Diagonal	100m Roll
ST75BRW	Red/White Diagonal	100m Roll
ST75BYB	Yellow/Black Diagonal	100m Roll



HI VIS Bunting Flags

- HI VIS orange PVC triangle flags
- Rectangular reflective yellow tabs for day/night use
- 45 flags over 30m length
- Reuseable high strength nylon rope



CODE	DESCRIPTION	UOM
TLINE5	HI VIS Orange Bunting Flags - 30m	Ea
TLINE4	HI VIS Orange Bunting Flags c/w Reflective Tabs - 30m	Ea



Barrier Safety Chain

- Manufactured from 8mm UV stabilised plastic
- Provides excellent visibility for both indoor and outdoor hazard areas
- Sold per metre or in roll lengths (25m)



CODE	DESCRIPTION	UOM
TCHAIN8	8mm Link Chain - Yellow	Per Metre or 25m Roll
TCHAIN9	8mm Link Chain - Red/White	Per Metre or 25m Roll



Road Safety Traffic Light

- High intensity double sided light
- UV stabilised high impact polyethylene case
- 18cm high impact polycarbonate lens
- Flashing (65FPM) or steady light mode
- Supplied with two 6V batteries and mounting bracket
- Automatic internal photo cell activation via manual key



CODE	DESCRIPTION	UOM
TRLSLY	Road Safety Traffic Light	Ea



Foxfire LED Range

- 26 super bright LEDs
- Magnetic back/pullout stand
- Magnifier on each LED
- Front and side illumination
- Modes: constant on, flash, side-to-side
- Other colours available to order
- Dimensions: H50mm x W100mm x L160mm
- Requires four AA batteries



CODE	DESCRIPTION	COLOURS	UOM
TLP263	Foxfire LED Signal Light	Red, Amber, Blue, Red/Blue, Red/White	Ea



LED Traffic Batons

- Heavy duty
- TLPB411 operates in torch only mode, baton only mode, or combination torch and baton
- TLPB412 operates in either flash or static mode
- Requires two D batteries



CODE	DESCRIPTION	COLOURS	UOM
TLPB411	LED Traffic Baton & Torch D42mm x L410mm	Red c/w White Torch	Ea
TLPB412	LED Traffic Baton D45mm x L550mm	Red	Ea



Portable LED Beacon

- Compact and portable 360° LED light
- 24 super bright LEDs
- Magnetic base
- Requires two D batteries (not included)
- Switch activated Day/Night function



CODE	DESCRIPTION	DIMENSIONS	COLOURS	UOM
TL24	Portable LED Beacon	121mm(H) x 104mm(D)	Amber	Ea



Small LED Vehicle Beacons

- Hardwire or Magnetic Base with power adaptor and 4 metre cord
- Programmable flash pattern - 6 LEDs
- 12-24 VDC operating voltage
- SABS IP66 rated - CE certified

TL1206



CODE	DESCRIPTION	DIMENSIONS	COLOURS	UOM
TL1206	Hardwire LED Beacon - Small	95mm(H) x 129mm(D)	Amber, Red, Green,	Ea
TL1206M	Magnetic Base LED Beacon - Small	110mm(H) x 129mm(D)	Blue, Clear, Magenta	Ea



Titan LED Rotating Beacons

- Low profile heavy duty beacon
- Direct silicone drive for quieter operation
- 12 x 3 watt high powered LEDs
- CE and EMC/EMI certified
- Polycarbonate UV stabilised lens
- 12 - 24 VDC

TL3024



CODE	DESCRIPTION	DIMENSIONS	COLOURS	UOM
TL3024	Hardwire Titan LED Beacon	141mm(H) x 161mm(D)	Amber, Red, Green, Blue,	Ea
TL3024M	Magnetic Base LED Beacon	161mm(H) x 161mm(D)	Magenta, Clear	Ea



Vehicle Rotating Beacons

- Hardwire or Magnetic Base with power adaptor and 4 metre cord
- 130 rotations per minute
- 12 VDC operating voltage option (24 VDC available)
- Meets IP65 protection standards



TL3124

CODE	DESCRIPTION	DIMENSIONS	COLOURS	UOM
TL3124	Hardwire Rotating Beacon	134mm(H) x 161mm(D)	Amber, Red, Green, Blue	Ea
TL3124M	Magnetic Base Rotating Beacon	151mm(H) x 161mm(D)		Ea



VS LED Mini Bar

- 3 Watt amber LEDs with clear lens
- Lead length: 3.5m
- Double switched plug (On/Off & Flash Pattern Change)
- 10 selectable flash patterns
- Operating voltage: 12-24 VDC



TL17020M

CODE	NO OF LEDS	NO OF MAGNETIC FEET	DIMENSIONS	UOM
TL17019M	30	2	40mm(H) x 190mm(D) x 260mm(W)	Ea
TL17020M	36	4	50mm(H) x 166mm (D) x 360mm (W)	Ea



Vehicle Whip Aerials

- Sturdy fibreglass construction
- Quick release adapter and heavy duty spring mount
- HI VIS orange nylon mesh flag with silver reflective cross
- 1.8 and 2.4m versions are segmented for ease of storage



TLWAN18

CODE	DESCRIPTION	UOM
TLWAN12	1.2m Whip Aerial	Ea
TLWAN18	1.8m Whip Aerial in 2 Segments	Ea
TLWAN24	2.4m Whip Aerial in 2 Segments	Ea



Portable Warning Triangles

- Red reflective
- Side length 440mm
- Fold flat
- Set of 3 in sturdy hard case
- Complies with AS 3790:1992 and AS/NZS 1906.1:2007



CODE	DESCRIPTION	UOM
TLT3	Warning Triangles Set of 3	Set



Diamond Grade™ Reflective Vehicle Tape

- Highly reflective surface delivers high vehicle/object visibility
- Suitable for use on any hard surface areas including machinery, scaffolds and ladders
- Sealed edge prevents delamination
- Strong adhesive provides permanent bond to surfaces
- Meets AS 1906.2 Class 1A standards



CODE	DESCRIPTION	DIMENSIONS	COLOURS	UOM
STV983-13R15	Diamond Grade Vehicle Marking Tape	50mm x 15m	White, Yellow, Red	Roll
STV983-15R15	Diamond Grade Vehicle Marking Tape Fluorescent	50mm x 15m	Fluorescent Yellow/Green	Roll
STV983-13-R3	Diamond Grade Vehicle Marking Tape	50mm x 3m	White, Yellow, Red, Yellow/Red, Red/White, Yellow/Black	Roll
STV983-15-R3	Diamond Grade Vehicle Marking Tape Fluorescent	50mm x 3m	Fluorescent Yellow/Green	Roll



Indoor Convex Mirrors

- Durable, scratch resistant acrylic mirrors
- Ideal for indoor applications where easy viewing of unguarded areas is required
- Ball and swivel plates are attached directly to the mirror to reduce weight and costly installation
- Supplied with installation instructions and mounting brackets



CODE	DESCRIPTION	UOM
YM851307	Indoor Wall Mount 300mm	Ea
YM851308	Indoor Wall Mount 660mm	Ea
YM851309	Indoor Wall Mount 760mm	Ea



Economy Indoor Convex Mirrors

- Lightweight acrylic indoor mirrors
- Available in a range of sizes to suit workplace situations
- Supplied with installation instructions and mounting bolts



CODE	DESCRIPTION	UOM
YM844163	Indoor Economy Wall Mount 305mm	Ea
YM844164	Indoor Economy Wall Mount 457mm	Ea
YM833067	Indoor Economy Wall Mount 609mm	Ea
YM844165	Indoor Economy Wall Mount 760mm	Ea
YM856095	Indoor Economy Wall Mount 914mm	Ea



Outdoor Industrial Mirrors

- Weatherproof and UV resistant mirrors designed for both outdoor and indoor use
- Strong industrial mirror featuring a 160° wide, 120° angle that provides a full overhead view
- Lightweight acrylic mirrors with rubber rim & heavy duty backing
- Supplied with installation instructions and heavy duty steel mounting brackets



CODE	DESCRIPTION	UOM
YM833068	Outdoor Wall Mount 457mm	Ea
YM833072	Outdoor Wall Mount 610mm	Ea
YM844161	Outdoor Wall Mount 914mm	Ea
YM856109	Outdoor Wall Mount 457mm - Scratch Resistant	Ea
YM856110	Outdoor Wall Mount 660mm - Scratch Resistant	Ea
YM856112	Outdoor Wall Mount 914mm - Scratch Resistant	Ea



Heavy Duty Traffic Mirrors

- Engineered for use as a safety, security & surveillance mirror in high traffic areas
- High resolution image for extra safety
- Stainless steel, weatherproof mirror and backing is virtually unbreakable
- Supplied with instructions and heavy duty steel mounting brackets



CODE	DESCRIPTION	UOM
YM856096	Stainless Steel Outdoor Wall Mount 457mm	Ea
YM844406	Stainless Steel Outdoor Wall Mount 660mm	Ea
YM844404	Stainless Steel Outdoor Wall Mount 800mm	Ea
YMZ873898	Wall Mount Attachment for Traffic Mirror	Ea



Dome Mirrors

- Acrylic dome mirrors for indoor applications
- Additional sizes available

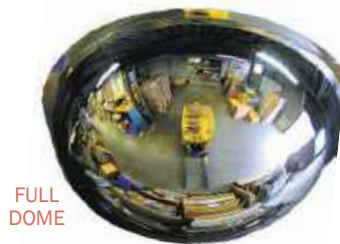

CODE	DESCRIPTION	SIZE	UOM	CODE	DESCRIPTION	SIZE	UOM	CODE	DESCRIPTION	SIZE	UOM
YMD844168	Full Dome	457mm	Ea	YMD833064	Half Dome	457 x 300mm	Ea	YMD844166	Quarter Dome	457mm	Ea
YMD844169	Ceiling Mount	609mm	Ea	YMD833065	Wall Mount	660 x 300mm	Ea	YMD856114	Corner Mount	660mm	Ea

VIEWING/INSTALLATION GUIDE

Choosing the Appropriate Mirror

To determine the correct mirror size, simply follow these step by step instructions:

Step 1: Estimate the distance from the viewer to the proposed mirror location.

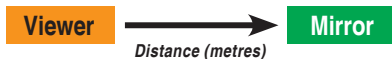

Step 2: Estimate the distance from the proposed mirror location to the area/object to be observed.



Step 3: Combine the previous distances. (Step 1 and Step 2). The total distance is your guide to the correct mirror size. Use the table shown to choose appropriate mirror size. If in doubt choose the larger size.



VIEWING DISTANCE GUIDE

Size of Mirror (diameter)	Best Distance
300mm	Up to 12 metres
450mm	Up to 15 metres
600mm	Up to 20 metres
760mm	Up to 25 metres
1000mm	Over 25 metres

Note: Viewing Distances are only a guideline and are recommended based on straight viewing. It is recommended to go up a size or two with multiple intersection or poor lighting areas.

SpillSmart

General Purpose Spill Kits

- Suitable for land based spills
- Absorbs water-based non-hazardous liquids: paints, coolants, hydrocarbons – including oils, fuels and grease
- Includes premium SpillSmart bioactive absorbents for rapid & effective clean up



DO NOT USE FOR AGGRESSIVE LIQUIDS & CHEMICALS

- Ideal solution for workshops and general work areas
- All kits supplied with nitrile gloves & instruction sheet

SpillSmart

General Purpose Bin Kits

- 120L or 240L yellow polyethylene bin options
- Heavy duty wheels



CONTENT ITEM	120L BIN YSGK120	240L BIN YSGK240
Floor Sweep	2 x 10kg	3 x 10kg
Socks	3 x 1.2m	4 x 1.2m, 1 x 3m
Pillows	1	2
Poly Pads - Heavyweight	25	40
Waste Bags	7	10
Dustpan	1	1

SpillSmart

General Purpose Bag Kits

- Range of bag sizes to suit both vehicle and fixed applications
- Heavy duty PVC construction with carry handles



CONTENT ITEM	SINGLE USE YSGK15	30L BAG YSGK30	50L BAG YSGK50	80L BAG YSGK80
Floor Sweep	1 x 2.5kg	1 x 5kg	1 x 5kg	1 x 10kg
Socks	1 x 1.2m	1 x 1.2m	1 x 1.2m	2 x 1.2m
Pillows	-	-	1	1
Poly Pads - Heavyweight	2	5	10	15
Waste Bags	-	3	3	3
Dustpan	-	1	1	1

SpillSmart

Oil & Fuel (Hydrocarbon) Spill Kits

- Suitable for both oil and fuel spills on land and water
- Repels water and only absorbs hydrocarbon
- Includes premium SpillSmart bioactive absorbents for rapid and effective clean up

DO NOT USE FOR AGGRESSIVE LIQUIDS & CHEMICALS



- Ideal solution for workshops and general work areas
- Also ideal for oil and fuel spills on water
- All kits supplied with nitrile gloves & instruction sheet

SpillSmart

Oil & Fuel (Hydrocarbon) Bin Kits

- 120L or 240L red polyethylene bin options
- Heavy duty wheels
- Includes nitrile gloves, stickers & instructions



CONTENT ITEM	120L BIN YSHK120	240L BIN YSHK240
Floor Sweep	2 x 10kg	3 x 10kg
Socks	3 x 1.2m, 1 x 3m	3 x 1.2m, 1 x 3m
Pillows	1	1
Poly Pads - Heavyweight	25	40
Waste Bags	7	10

SpillSmart

Oil & Fuel Bag Kits

- Range of bag sizes to suit both water craft and marina applications
- Heavy duty PVC construction with carry handles



CONTENT ITEM	SINGLE USE YSHK15	30L BAG YSHK30	50L BAG YSHK50	80L BAG YSHK80
Socks	1 x 1.2m	1 x 1.2m	3 x 1.2m	4 x 1.2m
Pillows	-	-	1	1
Poly Pads - Heavyweight	10	20	25	40
Waste Bags	-	3	3	3

SpillSmart

HAZCHEM Spill Kits

- Suitable for spills of hazardous chemicals and aggressive liquids
- Flexible solutions for workplaces where chemicals are being transported, stored or used in daily processes



DO NOT USE FOR REMOVAL OF OIL FROM WATER

- Includes SpillSmart Hazsorb and HazChem absorbents for rapid and effective clean up
- All kits supplied with nitrile gloves and instruction sheet

SpillSmart

HazChem Bin Kits

- 120L or 240L blue polyethylene bin options
- Heavy duty wheels



CONTENT ITEM	120L BIN YSCK120	240L BIN YSCK240
HazSorb	2 x 30L	3 x 30L
Socks	3 x 1.2m	4 x 1.2m, 1 x 3m
Pillows	1	1
Poly Pads - Heavyweight	25	40
Waste Bags	7	10
Dust Pan	1	1

SpillSmart

HazChem Bag Kits

- Range of bag sizes to suit both vehicle and fixed applications
- Heavy duty PVC construction with carry handles



CONTENT ITEM	SINGLE USE YSCK15	30L BAG YSCK30	50L BAG YSCK50	80L BAG YSCK80
HazSorb	1 x 7.5L	1 x 7.5L	3 x 7.5L	1 x 30L
Socks	1 x 1.2m	1 x 1.2m	1 x 1.2m	2 x 1.2m
Pillows	-	-	1	1
Poly Pads - Heavyweight	2	15	15	20
Waste Bags	-	3	3	3
Dust Pan	-	1	1	1

SpillSmart

Oil & Fuel - Marine Spill Kits

- Designed for marine based applications
- Specifically for use on oil and fuel on water e.g. rivers, marinas and boating
- Includes marine quality booms and heavy duty pads



CONTENT ITEM	120L BIN YSMK120	240L BIN YSMK240
Booms	2 x 3m x 125mm	2 x 3m x 125mm
Socks	2 x 1.2m	5 x 1.2m
Pillows	1	1
Poly Pads - Heavyweight	40	100
Waste Bags	7	10



ALL KITS ALSO AVAILABLE IN AUSSPILL SPILL KIT BIN COLOURS

SpillSmart

Drain Warden

- Designed for use in industrial facilities, construction sites and parking lots
- Contains an oil absorbent pillow that removes oils and greases from water flow as it passes through the drain filter
- Collects rubbish and other solids



CODE	DESCRIPTION	UOM
YSDF900	SpillSmart Drain Warden - 900 x 900mm, 450mm Basin	Ea
YSDF1200	SpillSmart Drain Warden - 1200 x 1200mm, 600mm Basin	Ea

SpillSmart

Absorbent Socks, Pads, Pillows & Rolls



GENERAL PURPOSE

CODE	DESCRIPTION	SIZE	UOM
YSGP4843P	SpillSmart Pad Poly - Heavyweight	48cm x 43cm	Bale/100
YSGP4545P	SpillSmart Pillow Poly	45cm x 45cm	Each
YSGR9644P	SpillSmart Roll Poly	96.5cm x 44m	Roll
YSGS7512P	SpillSmart Sock Poly	75mm x 1.2m	Each
YSGS75300	SpillSmart Sock Poly	75mm x 3.0m	Each

OIL & FUEL ONLY

CODE	DESCRIPTION	SIZE	UOM
YSHP4843P	SpillSmart Pad Poly - Heavyweight	48cm x 43cm	Bale/100
YSHP4843PL	SpillSmart Pad Poly - Lightweight	48cm x 43cm	Bale/200
YSHP4545P	SpillSmart Pillow Poly	45cm x 45cm	Each
YSHR7644P	SpillSmart Roll Poly	96.5cm x 44m	Roll
YSHS7512P	SpillSmart Sock Poly	75mm x 1.2m	Each
YSHS7530P	SpillSmart Sock Poly	75mm x 3.0m	Each

HAZCHEM

CODE	DESCRIPTION	SIZE	UOM
YSCP4843P	SpillSmart Pad Poly - Heavyweight	48cm x 43cm	Bale/100
YSCP4545P	SpillSmart Pillow Poly	45cm x 45cm	Each
YSCR9644P	SpillSmart Roll Poly	96.5cm x 44m	Roll
YSCS7512P	SpillSmart Sock Poly	75mm x 1.2m	Each
YSCS7530P	SpillSmart Sock Poly	75mm x 3.0m	Each

SpillSmart

Aluminium Floor Bunding

- Robust permanent bund for liquid containment in high traffic areas
- Non-sparking, non magnetic marine grade ideal for use around flammable liquids and vapours
- Durable, low maintenance and easy to install
- AS 1940-2004 compliant
- Smooth Transition Technology for ease of use

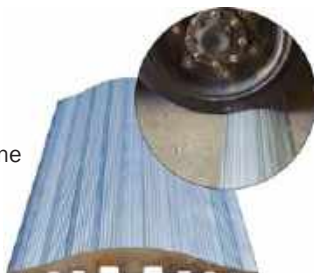

CODE	DESCRIPTION	UOM
YSAFB	SpillSmart Aluminium Floor Bund - 1200mm(L) x 200mm(W) x 30mm(H)	Ea

SpillSmart

Spill Bund

- Provides spill containment in applications where hydrocarbons or potentially hazardous chemicals/liquids are stored
- Flexible side walls allow for simple delivery of liquid storage drums
- Made from a strong, chemically resistant and UV-stable polymer coated fabric
- Lightweight and easy to clean
- Custom sizes available



CODE	DESCRIPTION	UOM
YSSB2424	SpillSmart Spill Bund - 2.4m x 2.4m	Ea
YSSB6060	SpillSmart Spill Bund - 6.0m x 3.0m	Ea

SpillSmart

Absorbents

All Purpose Absorbent

- Inert mineral based absorbent
- Safe for use on strong acid & alkaline solutions
- Suitable for petroleum, hydrocarbons, oils, solvents, sewage and protein-based fluids



Floor Sweep Absorbent

- Manufactured from organic cellulose materials
- Quickly absorbs petroleum, oils, fuels, solvents, cooking oils, sewage and protein-based fluids
- Not to be used on strong acid & alkaline solutions



HazSorb Absorbent

- Inert, non toxic vermiculite absorbent
- Effective for hazardous chemical spills
- Can be used for body fluid spills and typical hydrocarbon spills on land



Road Spill Absorbent

- Manufactured from organic cellulose materials
- Absorbs petroleum, oils, fuels, solvents, cooking oils, sewage and protein-based fluids
- Leaves paved surfaces dry significantly reducing the potential of slips
- Not to be used on strong acid & alkaline solutions



CODE	DESCRIPTION	UOM
YSAAP22	SpillSmart AllPurpose Absorbent - 22L	Ea
YSAFS10	SpillSmart Floor Sweep Absorbent - 10kg	Ea
YSAHZ10	SpillSmart HazSorb Absorbent - 30L	Ea
YSARS12	SpillSmart Road Spill Absorbent - 12kg	Ea

SpillSmart



Collapsible Bund

- SpillSmart lightweight collapsible bunding provides temporary storage of hazardous chemicals and liquids where vehicle access is required
- Walls easily collapse and re-erect
- Easy to transport, store and clean
- Wide range of standard sizes available

CODE	DESCRIPTION	UOM
YSCB2424	SpillSmart Collapsible Bund - 2.4m x 2.4m	Ea
YSCB3434	SpillSmart Collapsible Bund - 3.4m x 3.4m	Ea

**Bunding available in custom sizes
Call for pricing**



Hazmat Spill Control Pallets

- Seamless construction eliminates leaks
- Wide forklift pockets
- Self-locating grates
- 100% recycled polyethylene
- Impervious to most chemicals, acids and corrosives
- EPA Compliant



YES28635



CODE	DESCRIPTION	UOM
YES28623	Hazmat Spill Pallet - 2 Drum In-line	Ea
YES28627	Hazmat Spill Pallet - 3 Drum In-line	Ea
YES28635	Hazmat Spill Pallet - 4 Drum Square	Ea



Hazmat Accumulation Centre

- Sturdy self-locating grates



Image shows 3 x 2-drum unit with ramp

- Companion ramp facilitates loading
- Low profile seamless construction in 100% recycled polyethylene
- 4, 6 & 8 drum modules also available
- 'Sump to Sump Drain Kit' available
- Requires Joining Clips if used in combination format

CODE	DESCRIPTION	UOM
YES28655	Hazmat Accumulation Centre - 2 Drum	Ea
YES28687	Hazmat Accumulation Centre Ramp	Ea
YES28927	Sump to Sump Drain Kit	Ea



Outdoor Sheds

- Reliable and secure outdoor storage for intermediate bulk containers
- Robust design made from 40% recycled polyethylene
- Lockable roll-top door for dual access (c/w reach pole)
- Can be used with IBC pallet bund, 4 drum option available



Example of use with IBC Pallet Bund.



CODE	DESCRIPTION	UOM
YES28675	Ecopolyblend Drum Shed - 2 Drum	Ea
YES28676	Ecopolyblend Drum Shed - 4 Drum	Ea
YES28677	Ecopolyblend IBC Shed	Ea



Dispensing & Storage Safety Cans

- Heavy duty, high grade coated, lead free steel construction
- Positive pressure relief venting
- Flash arrester eliminates flashback risk

BD7150100



CODE	DESCRIPTION	UOM
BD7250130	19L Dispensing Can	Ea
BD7150140	19L Shelf Dispensing Can	Ea
BD7120100	7.6L Storage Can	Ea
BD7150100	19L Storage Can	Ea

BD7250130



IBC Pallet Bund

- 40% recycled polyethylene
- EPA compliant for 1000 and 1250 litre IBC's
- Sturdy pillar supports - chemical and corrosion resistant
- Dimensions:
W: 1397mm
D: 1397mm
H: 952mm



CODE	DESCRIPTION	UOM
YES28674	IBC Pallet Bund Indoor 1408L	Ea



Weatherproof Outdoor Flammable Liquid Cabinets

- Yellow powder coated steel construction
- Stainless steel hinges
- Forklift channels help keep the cabinet dry at ground level
- Sloping roof to front with weatherproof guttering
- Compliance with AS 1940 for the storage of flammable and combustible liquids



BC25602WP



BC25452WP



BC25302WP

CODE	DESCRIPTION	UOM
BC25302WP	Outdoor Flammable Storage Cabinet 1230mm(H) x 1100mm(W) x 465mm(D) - 160L	Ea
BC25452WP	Outdoor Flammable Storage Cabinet 1760mm(H) x 1100mm(W) x 465mm(D) - 250L	Ea
BC25602WP	Outdoor Flammable Storage Cabinet 1760mm(H) x 870mm(W) x 870mm(D) - 350L	Ea



Manifest Cabinet

- Document storage cabinet
- Dimensions: 500mm (H) x 400mm (W) x 130mm (D)
- Document storage for HAZMAT, SDS and emergency information



CODE	DESCRIPTION	UOM
BC25001	Manifest Cabinet	Ea

JUSTRITE®

Flammable Liquid Storage Cabinets

- Fire tested, FM Approved, exceeds AS 1940
- Fully welded construction, 1.2mm steel
- Double wall - 40mm thermal barrier
- Self-closing and latching doors
- High gloss powder coated
- Dual vents c/w built-in flash arresters



CODE	DESCRIPTION	UOM
BC25748	100L Flammable Liquid Storage Cabinet	Ea
BC25302	160L Flammable Liquid Storage Cabinet	Ea
BC25452	250L Flammable Liquid Storage Cabinet	Ea

JUSTRITE®

Corrosive Substance Storage Cabinets

- Fire tested, FM Approved, exceeds AS 3780
- Polyethylene trays for corrosive resistancy
- Fully welded construction, 1.2mm steel
- Double wall - 40mm thermal barrier
- Self-closing and latching doors
- Dual vents c/w built-in flash arresters



CODE	DESCRIPTION	UOM
BC25748B	100L Corrosive Substance Storage Cabinet	Ea
BC25302B	160L Corrosive Substance Storage Cabinet	Ea
BC25452B	250L Corrosive Substance Storage Cabinet	Ea

JUSTRITE®

Class 6 Toxic Substance Storage Cabinets

- Conforms to AS 4452-1997
- Exclusive 'spillslope' shelves direct spills to back and bottom of the cabinet
- Patented concealed self-closing mechanism provides obstruction-free access to the top shelf
- 150mm sump contains spills or leaks within the cabinet



CODE	DESCRIPTION	UOM
BC25748T	100L Toxic Substance Storage Cabinet	Ea
BC25302T	160L Toxic Substance Storage Cabinet	Ea
BC25452T	250L Toxic Substance Storage Cabinet	Ea

JUSTRITE®

Pesticide/Herbicide Storage Cabinets

- Conforms to AS 4452-1997
- 'Suregrip' handle is lockable and allows for fitting of a padlock as extra security
- Shelves are adjustable at 76mm increments
- Doors are self-closing and feature a 3-point latching system



CODE	DESCRIPTION	UOM
BC25748P	100L Pesticide Storage Cabinet	Ea
BC25302P	160L Pesticide Storage Cabinet	Ea
BC25452P	250L Pesticide Storage Cabinet	Ea



Class 3 Flammable Liquid Storage Cabinets - Single Door

- Flammable liquids include paints, solvents, petrol, thinners, kerosene, turpentine, white spirits, alcohol and ethanol
- Combustible liquids include diesel, linseed oil and pine oil
- Material of construction: double steel walls
- Doors: single, self-closing, self-latching
- Double door configurations also available
- Shelves: roller set
- Australian standard: AS 1940



BC5560ASE

CODE	DESCRIPTION	UOM
BC5560ASE	Metal Flammable Liquid 350L 1 Door/3 Shelf	Ea
BC5555VS	Metal Flammable Liquid 205L 1 Door Roller Set Shelf	Ea



Aerosol Storage Cage

- Powder coated steel construction, suitable for outdoors
- Steel roof and floor with welded steel mesh sides within a steel frame
- Magnetic door catches with eye lug for padlock
- Flat pack or assembled options - includes appropriate safety signs



MLG164A

CODE	DESCRIPTION	CAN CAPACITY	H	W	D
MLGC1AFP	Flat Pack 1 Level	42	360	560	490
MLGC2AFP	Flat Pack 2 Levels	84	660	780	760
MLGC4AFP	Flat Pack 2 Levels	200	990	780	760
MLGC8AFP	Flat Pack 4 Levels	400	1920	780	760
MLGC16AFP	Flat Pack 8 Levels	800	1920	1520	760
MLGC4A	Assembled 2 Levels	200	990	780	760
MLGC8A	Assembled 4 Levels	400	1920	780	760
MLGC16A	Assembled 4 Levels	800	1920	1520	760



Gas Cylinder Storage Cage

- Powder coated steel construction, suitable for outdoors
- Steel roof and floor with welded steel mesh sides within a steel frame
- Magnetic door catches with eye lug for padlock
- Cylinder restraining chain
- Flat pack or assembled options - includes appropriate safety signs



MLGC9V

CODE	DESCRIPTION	CYLINDER CAPACITY	H	W	D
MLGC9VFP	Flat Pack 1 Level	9 (G)	1920	780	760
MLGC18VFP	Flat Pack 2 Levels	18 (G)	1920	1520	760
MLGC9V	Assembled 1 Level	9 (G)	1920	780	760
MLGC18V	Assembled 2 Levels	18 (G)	1920	1520	760



Class 8 Corrosive Substance Storage Cabinets - Poly

- Corrosives include chemicals such as acids, alkalis, caustics, sodium hydroxide solution and hypochlorite solution
- Material of construction: polypropylene - check compatibility of chemicals (must be in sealed and closed containers)
- Doors: single and double, self-closing and self-latching
- Australian standard: AS 3780



BC5512PSPH

CODE	DESCRIPTION	UOM
BC5512PSPH	Poly Corrosive 20L 1 Door/1 Shelf	Ea
BC5535PSPH	Poly Corrosive 100L 2 Door/1 Shelf	Ea
BC5516PSPH	Poly Corrosive 40L 1 Door/1 Shelf	Ea
BC5540PSPH	Poly Corrosive 110L 2 Door/2 Shelf	Ea
BC5517PSPH	Poly Corrosive 80L 1 Door/2 Shelf	Ea
BC5530PSPH	Poly Corrosive 160L 2 Door/4 Shelf	Ea
BC5545PSPH	Poly Corrosive 240L 2 Door/6 Shelf	Ea



Forklift Cylinder Storage Cage

- Powder coated steel construction, suitable for outdoors
- Steel roof and floor with welded steel mesh sides within a steel frame
- Magnetic door catches with eye lug for padlock
- Cylinder restraining chain
- Flat pack or assembled options - includes appropriate safety signs



MLGC4F

CODE	DESCRIPTION	CYLINDER CAPACITY	H	W	D
MLGC4FFP	Flat Pack 1 Level	4	990	780	760
MLGC8FFP	Flat Pack 2 Levels	8	1920	780	760
MLGC16FFP	Flat Pack 4 Levels	16	1920	1520	760
MLGC4F	Assembled 1 Level	4	990	780	760
MLGC8F	Assembled 2 Levels	8	1920	780	760
MLGC16F	Assembled 4 Levels	16	1920	1520	760



Forklift & Gas Cylinder Storage Cage

- Powder coated steel construction, suitable for outdoors
- Steel roof and floor with welded steel mesh sides within a steel frame
- Magnetic door catches with eye lug for padlock
- Cylinder restraining chain
- Forklift cylinder storage cages include shelf to provide storage on two levels
- Flat pack or assembled options - includes appropriate safety signs



MLGC8F9V

CODE	DESCRIPTION	CYLINDER CAPACITY	H	W	D
MLGC8F9VFP	Flat Pack 3 Levels	8 (F) 9 (G)	1920	1520	760
MLGC8F9V	Assembled 3 Levels	8 (F) 9 (G)	1920	1520	760

JUSTRITE® Cylinder Storage Lockers

- Weather resistant all welded aluminium security lockers
- Durable and secure vertical storage for LPG and compressed gas cylinders
- Fully assembled - modular options to choose from
- Supplied with flammable gas or oxygen & inert gas signage as required
- Manufactured to comply with AS 4332.2004



ML23006

CODE	DESCRIPTION	UOM
ML23006	Up to 9 G Size Cylinders 760W x 1800H x 815D mm	Ea
ML23007	Up to 18 G Size Cylinders 1510W x 1800H x 815D mm	Ea
ML23009	1 - 4 Cylinders Vertical 760W x 960H x 815D mm	Ea
ML23014	Up to 3 G Size Cylinders 760W x 1800H x 415D mm	Ea

BRADY®

Pipe Markers & Identification

- Self sticking vinyl adhesive markers for easy installation
- Premium indoor/outdoor grade vinyl
- Weather resistant inks provide 5-8 year performance
- Colour code compliant with AS 1345-1995



MORE STYLES AVAILABLE INCLUDING CUSTOMISATION

TYPE	COLOUR CODE	SIZES
Alkalis / Acids	White On Violet	Marker sizes to suit pipe diameter
Air	White On Light Blue	
Fire Protection	White On Red	
Oils	White On Brown	
Electrical	White On Orange	
Medical Gases	Individual Colours For Specific Gases	
Gases	Black On Sand	
Miscellaneous	White On Black	

BRADY®

HAZCHEM Signage

- Dangerous goods vinyl adhesive diamonds - 250mm
- HAZCHEM metal warning and emergency information signs



SSV835494



SSV835481 SSV835484 SSV835482
SSV835496 SSV835483 SSV837007
SSV835490 SSV835493 SSV835488

JUSTRITE® Document Storage Boxes

- Weather resistant - keeps documents clean and dry
- High density polyethylene construction
- Heavy duty duct tape for drill-free mounting
- High visibility red colour with designated area for labelling



CODE	DESCRIPTION	INTERNAL DIMENSIONS	UOM
MS23303	Medium Top Opening Box	292 x 222 x 41mm	Ea
MS23304	Medium Front Opening Box	311 x 219 x 25mm	Ea
MS23305	Twist Top Opening Tube	305 x 76mm	Ea
MS23306	Large Front Opening Box	337 x 263 x 57mm	Ea

BOTTLECHOCK™ By VISION Safe



BOTTLECHOCK Cylinder Restraints

- Purpose designed to keep cylinders secure
- Suits gas cylinders, oxygen tanks, fire extinguishers, oil drums, etc.
- Restricts both horizontal and vertical movement
- Easy fit kit comes ready to install with galvanised steel mounting bracket
- Quick release pins free up space when cylinder is not in use, and allow use in another location
- Sizes: Small (100-145mm), Medium (160-230mm), Large (245-375mm)
- Also available in stainless steel
- Available with red or yellow chock

CODE	DESCRIPTION	COL.	UOM
MCRBG1L	Galvanised Restraint 245-375mm - 1 bottle	Red, Yellow	Ea
MCRBG1M	Galvanised Restraint 160-230mm - 1 bottle		Ea
MCRBG1S	Galvanised Restraint 100-145mm - 1 bottle		Ea
MCRBG2L	Galvanised Restraint 245-375mm - 2 bottles		Ea
MCRBG2M	Galvanised Restraint 160-230mm - 2 bottles		Ea
MCRBG2S	Galvanised Restraint 100-145mm - 2 bottles		Ea
MCRBG3M	Galvanised Restraint 160-230mm - 3 bottles		Ea
MCRBG3S	Galvanised Restraint 100-145mm - 3 bottles		Ea
MCRBG4M	Galvanised Restraint 160-230mm - 4 bottles		Ea
MCRBG4S	Galvanised Restraint 100-145mm - 4 bottles		Ea



(COMPOSITE CUSTOM WARNING)



SSM832040



SSM832041



SSM833620



TRANSPORT CUSTOM SIGN

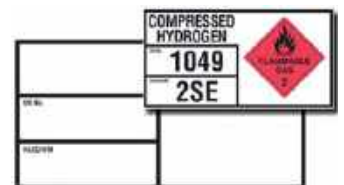

STORAGE & HANDLING CUSTOM SIGN

MAXSafe

Lead Stands & Hooks

Can be used for electrical cables, air hoses and cords.

Poly Base Lead Stand

- Non-conductive fibreglass pole - 1.2m - 2.4m (H)
- Plastic lead holder

Metal Base Lead Stand

- Metal base & pole - 1.2m - 2.4m (H)
- Plastic lead holder

Standard Lead Hook

- Non-conductive & non-corrosive
- Plastic lead holder

Heavy Duty Lead Hook

- Non-conductive & non-corrosive
- Tested to 50kg SWL

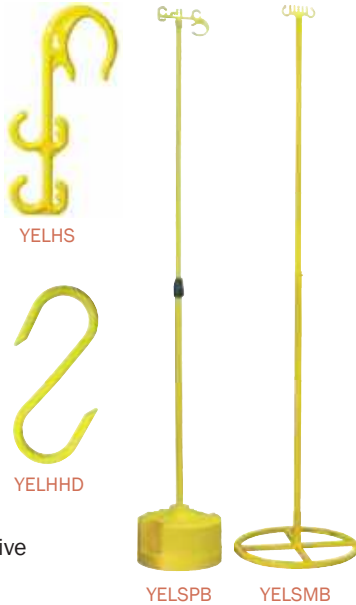

CODE	DESCRIPTION	UOM
YELSPB	Lead Stand Poly Base	Ea
YELSMB	Lead Stand Metal Base	Ea
YELHS	Lead Hook Standard	Ea
YELHHD	Lead Hook Heavy Duty	Ea



Lead Safety Stand

- Elevates leads & hoses up to 4m
- Non-conductive lead hooks
- Ground spike for outdoor use
- Comes in carry bag
- Fits in 1.2m tool box/site box

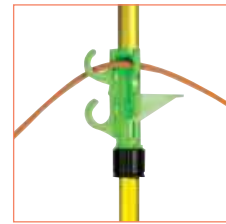

CODE	DESCRIPTION	UOM
YELSLQ	LeadQuip Lead Stand	Ea



OktoLock™ Cable & Cord Clip

- Mitigates potential trip hazards
- Completely dielectric
- Strong, flexible and durable PC/ABS plastic
- Secures and elevates cables, hoses and cords
- 34kg weight capacity per clip
- Available in black and yellow



CODE	DESCRIPTION	UOM
YELCC0203	OktoLock Clip	Ea



Cable Protectors

- Provides safe passage for pedestrians and/or light vehicles
- Protects valuable cables and hoses
- Interlocking modules
- Robust construction in HI VIS safety yellow

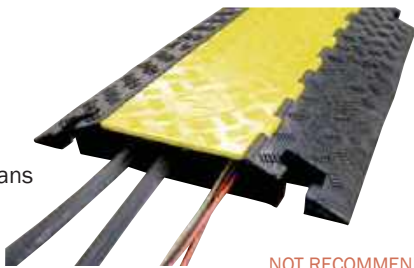

NOT RECOMMENDED FOR FORKLIFT OR TRUCK TRAFFIC

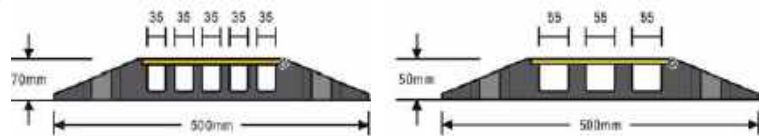

CODE	DESCRIPTION	UOM
YELCP1BODY	Cable Protector Light Vehicle - 1 Channel 1.0m Length	Ea
YELCP2BODY	Cable Protector Light Vehicle - 2 Channel 1.0m Length	Ea
YELCP3BODY	Cable Protector Light Vehicle - 3 Channel 0.9m Length	Ea
YELCP5BODY	Cable Protector Light Vehicle - 5 Channel 0.9m Length	Ea



RB8-6 Industrial 32A Power board

- 6 outlet 'plug & play' distribution board - IP66 rated
- 32A 3 phase inlet to 6 x 15A single phase outlets, individually RCD protected
- 1.8m earth screened lead



CODE	DESCRIPTION	UOM
YELIB8632A	Powerboard 32A	Ea



Guardian Power Board

- 'Plug & play' temporary distribution board
- 4 way - 240V single phase
- IP66 rating
- Fitted earth screened lead



CODE	DESCRIPTION	UOM
YELPBHD10	Guardian Power Board 10A	Ea
YELPBHD15	Guardian Power Board 15A	Ea



RB4 Small Industrial Single Phase Distribution Board

- 4 outlet 'plug and play' distribution board - IP66 rated
- Includes 1.8m earth screened braided lead with 10A 240V 3 pin plug IP66



CODE	DESCRIPTION	UOM
YELIB410	Powerboard 4 x 10A	Ea
YELIB415	Powerboard 4 x 15A	Ea



415V 32A Three Phase Leads

- High flex H07 rubber insulated cable
- Fitted with 32A 5 pin (56) IP66 plug and socket
- AS/NZS 3112, 3120, 1391 & 3199



CODE	DESCRIPTION	UOM
YELRL103256	Three Phase Rubber Lead 32A - 10m	Ea
YELRL203256	Three Phase Rubber Lead 32A - 20m	Ea



240V Single Phase Braided Leads

- Earth screened 10A or 15A leads
- Super flexible cable
- 240V single phase - IP66 rating
- AS/NZS 3112, 3120, 1391 & 3199



CODE	DESCRIPTION	UOM
YELBL1010	Single Phase Braided Lead 10A - 10m	Ea
YELBL2010	Single Phase Braided Lead 10A - 20m	Ea



RCD Duo

- Inline earth fault protection for generators and inverters
- 240V - 10A or 15A



CODE	DESCRIPTION	UOM
YELRCDU010A	RCD DUO Inline 10A	Ea
YELRCDU015A	RCD DUO Inline 15A	Ea

Fireworld

ABE Dry Chemical Fire Extinguisher

- Suitable for Class A, B & E fires
- Dry chemical powder
- Effective against fire involving ordinary and flammable combustibles, liquids & energised electrical equipment



CODE	DESCRIPTION	UOM
BFABE10	Extinguisher Dry Chemical 1.0kg - ABE	Ea
BFABE20	Extinguisher Dry Chemical 2.0kg - ABE	Ea
BFABE45	Extinguisher Dry Chemical 4.5kg - ABE	Ea
BFABE90	Extinguisher Dry Chemical 9.0kg - ABE	Ea
SDEXT:ABE	Fire Extinguisher Indication Sign - 'ABE'	Ea

Fireworld

BE Dry Chemical Fire Extinguisher

- Suitable for Class B, E & F fires
- Dry chemical powder
- Effective against fire involving flammable combustible liquids and energised electrical equipment



CODE	DESCRIPTION	UOM
BFBE10	Extinguisher Dry Chemical 1.0kg - BE	Ea
BFBE23	Extinguisher Dry Chemical 2.3kg - BE	Ea
BFBE45	Extinguisher Dry Chemical 4.5kg - BE	Ea
BFBE90	Extinguisher Dry Chemical 9.0kg - BE	Ea
SDEXT:BE	Fire Extinguisher Indication Sign - 'BE'	Ea

Fireworld

BE Carbon Dioxide Fire Extinguisher

- Suitable for Class B & E fires
- Effective against fire involving flammable combustible liquids and energised electrical equipment
- Ideal for use around computers etc.



CODE	DESCRIPTION	UOM
BFCO20	Extinguisher CO2 2.0kg - BE	Ea
BFCO35	Extinguisher CO2 3.5kg - BE	Ea
BFCO50	Extinguisher CO2 5.0kg - BE	Ea
SDEXT:CO2	Fire Extinguisher Indication Sign - 'CO2'	Ea

Fireworld

Air/Water and Air/Foam Fire Extinguishers

- Air/Water is suitable for Class A fires only (wood, paper, plastics)
- Air/Foam is suitable for Class A & B fires only (wood, paper, plastics and flammable/ combustible liquids)



CODE	DESCRIPTION	UOM
BFAW90	Extinguisher Air/Water 9.1L - A	Ea
SDEXT:AW	Fire Extinguisher Indication Sign - 'AW'	Ea
BFAF90	Extinguisher Air/Foam 9.1L - AB	Ea
SDEXT:AF	Fire Extinguisher Indication Sign - 'AF'	Ea

Fireworld Fire Extinguisher Selection Table

FIRE CLASSES		A	B	C	E	F	SPECIAL NOTES
		PAPER, WOOD, PLASTICS	FLAMMABLE LIQUIDS	FLAMMABLE GASES	ENERGISED ELECTRICAL EQUIPMENT	COOKING OILS AND FATS	
	WATER	YES	NO	NO	NO	NO	Dangerous if used on flammable liquid, energised electrical equipment and cooking oils and fats.
	FOAM AFFF	YES	YES	NO	NO	LIMITED	Dangerous if used on energised electrical equipment.
	WET CHEMICAL	YES	NO	NO	NO	YES	Dangerous if used on energised electrical equipment.
	DRY CHEMICAL AB(E)	YES	YES	YES	YES	NO	Look carefully to determine if it is a B(E) or AB(E) unit as their capabilities are different.
	DRY CHEMICAL B(E)	NO	YES	YES	YES	YES	Look carefully to determine if it is a B(E) or AB(E) unit as their capabilities are different.
	CARBON DIOXIDE	NO	LIMITED	NO	YES	LIMITED	Not suitable for outdoor use.

*"LIMITED" indicates that the fire extinguisher is not the first choice for that type of fire, it will have limiting fire extinguishing capability. Class D fires (involving combustible metals): use only special purpose extinguishers and seek expert advice.

Fireworld

Vehicle Fire Extinguisher Brackets

- Heavy duty 'Cannon' style bracket with quick release mechanism
- Quick release mechanism
- Secure bracket for 4.5kg and 9.0kg extinguishers
- Black powder coated



CODE	DESCRIPTION	UOM
BFZVMB45	Vehicle Mounting Bracket Cannon Style - 4.5kg	Ea
BFZVMB90	Vehicle Mounting Bracket Cannon Style - 9.0kg	Ea

Fireworld

Fire Hose Reels

- 36m hose reel length
- Simple operation and maintenance
- Meets requirements of AS 1221
- Heavy duty hose reel cover sold separately



BFZREELC



BFZREEL36

CODE	DESCRIPTION	UOM
BFZREEL36	Fire Hose Reel - 36m	Ea
BFZREELC	Fire Hose Reel Cover	Ea

Fireworld

Fire Blankets

- Woven fibreglass material
- Suitable for smothering small flammable liquid fires, cooking oil and fat fires
- Can be used to shield the user whilst fighting fires



FIRE BLANKET

SDBLA

CODE	DESCRIPTION	UOM
BB1010	Fire Blanket 1.0m x 1.0m	Ea
BB1212	Fire Blanket 1.2m x 1.2m	Ea
BB1218	Fire Blanket 1.2m x 1.8m	Ea
BB1818	Fire Blanket 1.8m x 1.8m	Ea
SDBLA	Sign 'FIRE BLANKET' Poly 220mm x 145mm	Ea

Fireworld

Mobile Fire Extinguisher Trolley

- Trolley makes it easy to move large capacity fire extinguisher to where it's needed
- Available with extinguisher capacities of 50kg or 100kg, in ABE (Dry Chemical) or AFFF (Foam)
- Overall height 50kg: 1100mm
- Overall height 100kg: 1250mm
- Extinguisher performance range: 3-5 metres



BFMAFF50

CODE	DESCRIPTION	UOM
BFMABE50	Mobile ABE 50kg 6A 80B E	Ea
BFMAFF50	Mobile AFFF 50kg 3A 30B	Ea
BFMABE100	Mobile ABE 100kg 6A 80B E	Ea
BFMAFF100	Mobile AFFF 100kg 3A 30B	Ea

Fireworld

Fire Extinguisher Cabinets

- Red powder coated steel cabinet
- Includes 003 'lock & key' in break glass
- Secure, highly visible storage for 4.5kg and 9.0kg extinguishers
- Dimensions: 4.5kg - 590mm(H) x 280mm(W) x 210mm(D)
- Dimensions: 9.0kg - 760mm(H) x 280mm(W) x 230mm(D)



CODE	DESCRIPTION	UOM
BFZCAB45	Extinguisher Cabinet - 4.5kg	Ea
BFZCAB90	Extinguisher Cabinet - 9.0kg	Ea

JUSTRITE®

Cease-Fire® Cigarette Butt Receptacle

- Low maintenance, high density polyethylene construction
- 40mm opening permits easy use and promotes good housekeeping
- 9L galvanised steel liner bucket
- Moulded in tie down notches
- 1200mm high with 420mm base

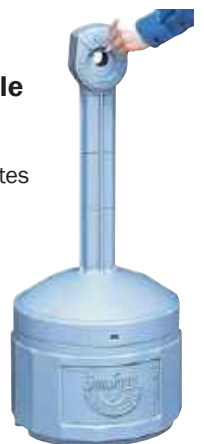

CODE	DESCR.	COLOURS	UOM
BD26800	Cease-Fire	Grey, Beige, Black, Green, Terracotta	Ea

BRADY®

Fire Safety Signage

- Suitable for fire safety and location requirements
- Vinyl adhesive directional signs for fire safety and evacuation
- Fire exit and escape sign sizes: 125mm x 300mm
- Fire equipment sign sizes: 600mm x 450mm

CODE	DESCRIPTION	UOM
SSV...	Fire Safety Signs - Vinyl Self Adhesive 125mm x 300mm	Ea
SSP...	Fire Safety Signs - Poly 600mm x 450mm	Ea
SSM...	Fire Safety Signs - Metal 600mm x 450mm	Ea

FIRE EXIT

SSV840976

FIRE ESCAPE →

SSV833463

← FIRE ESCAPE

SSV833462

FIRE ALARM
↓

SSP843018
SSM843019

FIRE HOSE REEL
↓

SSP841060
SSM834067

FIRE HOSE
↓

SSP841094
SSM841095

SPEAKMAN

Eyesaver® Eye Wash Units

- Rectangular stainless steel bowl
- Soft dual streams of aerated water
- Push bar operation for instant activation



YSE505

YSE546

CODE	DESCRIPTION	UOM
YSE505	Eye Wash Wall Mounted	Ea
YSE546	Pedestal Mounted Eye Wash Unit	Ea

SPEAKMAN

Eyesaver® Eye/Face Wash Units

- Rectangular stainless steel bowl with push hand operation
- Fast cleansing, low velocity first aid curtain of aerated water
- Washes eye and facial areas



YSE400

YSE480

CODE	DESCRIPTION	UOM
YSE400	Eye/Face Wash Wall Mounted	Ea
YSE480	Pedestal Mounted Eye/Face Wash Unit	Ea

SPEAKMAN

Lifesaver® Wall Mounted Deluge Shower

- Pull down stainless steel triangular ring with stay open valve
- Self-cleaning, non-clogging shower head
- Impeller action distributes floods of water without voids in the shower pattern

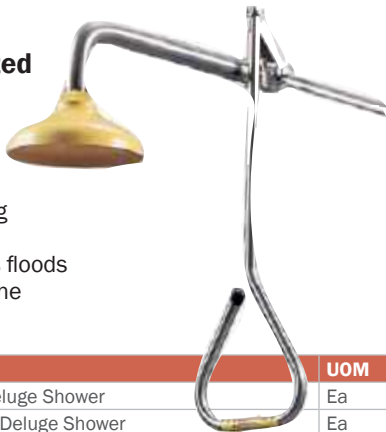

CODE	DESCRIPTION	UOM
YSE227	Wall Mounted Deluge Shower	Ea
YSE220	Ceiling Mounted Deluge Shower	Ea

SPEAKMAN

Portable Eye Wash Unit

- Gravity fed - no pressurisation necessary
- Portable for use in remote or temporary work environments
- 34 litre capacity provides 15 minutes of water flow



CODE	DESCRIPTION	UOM
YSE4400	Portable Eye Wash Unit - 34 Litres	Ea

SPEAKMAN

Portable Eye Wash Unit

- Gravity fed - no pressurisation necessary
- Portable for use in remote or temporary work environments
- 79 litre capacity provides 15 minutes of water flow



CODE	DESCRIPTION	UOM
YSE4000	Portable Eye Wash Unit - 79 Litres	Ea

SPEAKMAN

Free Standing Eye or Eye/Face Wash & Combination Shower Stations

- Pedestal style free-standing eye/face wash units
- Combination deluge showers with stainless steel eye or eye/face wash units
- Available in hand and/or foot operation mode



YSE616

YSE607

Scald Protection Valve

- The HAT/SP opens only when the water exceeds safe limits: 35 degrees

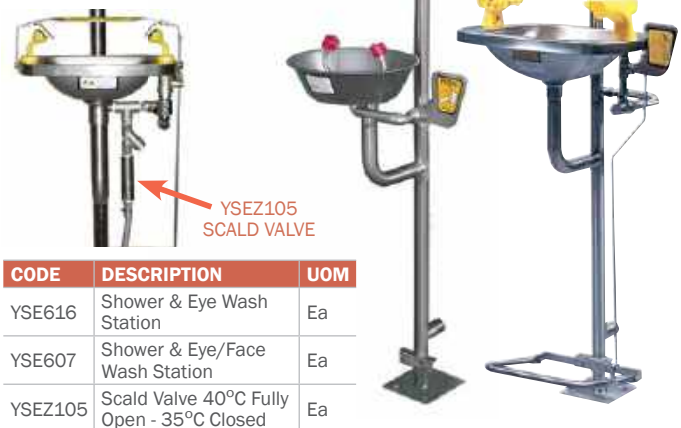

YSEZ105
SCALD VALVE

CODE	DESCRIPTION	UOM
YSE616	Shower & Eye Wash Station	Ea
YSE607	Shower & Eye/Face Wash Station	Ea
YSEZ105	Scald Valve 40°C Fully Open - 35°C Closed	Ea

All SPEAKMAN emergency eye wash and shower equipment complies with AS 4775-2007.



Combination Shower With Eye & Face Wash Nozzle with Bowl & Foot Treadle

- Versatile decontamination system designed to operate as an individual shower or face wash or both simultaneously
- Constructed mainly from 304 stainless steel material to provide a long service life in most environments
- Nozzle outlets for a soft and even water pattern, include self-closing dust cover on eye/face wash to protect from airborne contaminants
- Range of accessories available to provide correct operational temperature, illumination and identification



YSCSE607



SSPEESAE4530P



YSE600TCF

CODE	DESCRIPTION	UOM
YSCSE607	Shower Combination - Eye & Face Wash Nozzle	Ea
YSE850	Shower Head with Impeller Stainless Steel	Ea
YSEASV	Shower Valve Anti Scald 95°F/35°C Rated	Ea
YSE600TCF	Shower Thermal Insulation Foil Roll	Ea
YPSGL2	Shower Light Kit Weather Resistant Green Fluoro	Ea
SSPEESAE4530P	Safety Sign Poly 'Emergency Shower & Eye Wash' 450 x 300mm	Ea
SPPSSMB1	Safety Sign Bracket Stanchion Mounting	Ea



Free Standing Combination Shower/Eye/Face Wash Stations

- Combination shower and eye or eye/face wash for general applications
- Hand or hand & foot operated option
- Nozzles are available in single or AEROSTREAM triple nozzle configuration
- Key structural components made from stainless steel (304/316)
- Australian Standard: AS 4775
- Units stand 2450mm in height
- Flip Top Lid option
- Other combinations available



FLIP TOP LID

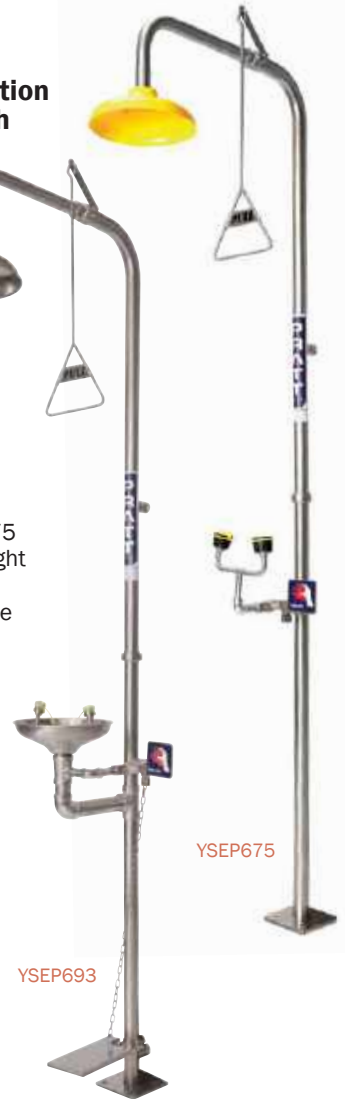

YSEP675

YSEP693

CODE	DESCRIPTION	UOM
YSEP693	Shower/Eye Wash Unit, Single Nozzle, Hand & Foot Operated	Ea
YSEP693FTL	Shower/Eye Wash Unit, Single Nozzle, Hand & Foot Operated, Flip Top Lid	Ea
YSEP675	Shower/Eye Wash Unit, Single Nozzle, Hand Operated	Ea



Wall Mounted Eye & Face Wash Units

- Dual design aerated eye/face wash for general applications
- Hand or hand & foot operated
- 304 stainless steel construction
- Single nozzle configuration
- With or without bowl option
- Nozzles with dust covers
- Australian Standard: AS 4775



YSEP505

YSEP575

YSEP582FTL

CODE	DESCRIPTION	UOM
YSEP505	Eye Wash Unit, Single Nozzle, Hand Operated	Ea
YSEP575	Eye Wash Unit, Single Nozzle, Hand Operated, No Bowl	Ea
YSEP582FTL	Eye Wash Unit, Single Nozzle, Hand Operated, Flip Top Lid	Ea



Portable Gravity Fed Eye Wash Unit - 55L

- Effective solution for an eyewash station where plumbed water is not available
- Suitable for initial first aid treatment for chemical burns and injuries
- Includes 1x bottle of water preservative, 1x wall mounting bracket, 1x test tag
- Dimensions: 530mm x 495mm x 600mm
- Material of construction: polyethylene
- Thermal cover available
- AS 4775 & ANSI Z358.1



YSEPZ5050TC

CODE	DESCRIPTION	UOM
YSEP5050	Portable Eye Wash Unit - 55L	Ea
YSEPZ5050TC	Thermal Cover for YSEP5050	Ea
YSZ4764	Water Preservative - 250ml	Pk/4

BRADY

Safety Plus Padlock Pack

- Pre-packaged set of 3 keyed-alike Safety Plus padlocks
- 6mm shackle



CODE	DESCRIPTION	UOM
SLP853205	Padlock Pack - Red	Pk/3
SLP853206	Padlock Pack - Yellow	Pk/3
SLP853207	Padlock Pack - Blue	Pk/3
SLP853208	Padlock Pack - Green	Pk/3

BRADY

Compact Lockout Padlocks

- Designed specifically for use in electrical lockout applications
- Small size and shackle diameter for use on smaller lockout devices
- Non-conductive, spark resistant body



CODE	DESCRIPTION	UOM
SLP872880	Compact Padlock - Red	Ea
SLP872881	Compact Padlock - Yellow	Ea
SLP872875	Compact Padlock - Blue	Ea
SLP872877	Compact Padlock - Green	Ea

BRADY

Adjustable Gate Valve Lockout

- Durable polypropylene construction
- Fits multiple size gates
- Completely encloses handle to prevent tampering



CODE	DESCRIPTION	UOM
SLD64057	Adjustable Gate Valve Lockout - Red	Ea
SLD850835	Adjustable Gate Valve Lockout - Yellow	Ea

BRADY

Labelled Lockout Hasp

- Anodised aluminium alloy
- Combination lockout tag and safety lockout hasp
- Up to five additional locks can be affixed
- Surface accepts pens, pencils and markers



CODE	DESCRIPTION	UOM
SLH65960	Labelled Lockout Hasp	Pk/5
SLH65960/1	Labelled Lockout Hasp	Ea

BRADY

Group Lock Box

- Simplifies lockout for large plant and equipment
- Accepts up to 13 individual locks
- Heavy steel construction, available in red or blue



CODE	DESCRIPTION	UOM
SLB65699	Group Lock Box - Red	Ea
SLB45190	Group Lock Box - Blue	Ea

BRADY

Safety Plus Padlocks

- Compact and ultra lightweight
- Corrosion and chemical resistant
- Non-conductive body enhances safety in electrical applications
- Available in 8 colours: Blue, Green, Yellow, Red, Purple, White, Black and Orange
- Comes with two keys and danger label
- 6mm shackle



CODE	DESCRIPTION	UOM
SLP850816	Safety Plus Padlock - Blue - Keyed Differently	Ea
SLP850818	Safety Plus Padlock - Green - Keyed Differently	Ea
SLP850820	Safety Plus Padlock - Yellow - Keyed Differently	Ea
SLP850821	Safety Plus Padlock - Red - Keyed Differently	Ea

BRADY

Safety Lockout Hasps

- Vinyl coated high tensile steel
- Plated to resist rust
- Accept 6 padlocks up to 9mm shackle diameter



CODE	DESCRIPTION	UOM
SLH65375/1	25mm Diameter Jaws	Ea
SLH65376/1	38mm Diameter Jaws	Ea

BRADY

Lockout Tags

- Weather resistant polypropylene
- 150mm x 100mm



CODE	DESCRIPTION	UOM
STG842384	Tag 'CAUTION DO NOT START'	Pk/10
STG842377	Tag 'DANGER DO NOT OPERATE'	Pk/10
STG842386	Tag 'CAUTION OUT OF ORDER'	Pk/10

BRADY

Wallmount Group Lockout Box

- Efficient method for lockout of machinery with multiple lockout points
- Keeps padlocks clean, organised and ready for use
- Easy access, highly visible



CODE	DESCRIPTION	UOM
SLB854243	Group Lock Box - 7 Hole	Ea
SLB854244	Group Lock Box - 12 Hole	Ea
SLB854245	Group Lock Box - 26 Hole	Ea



Personal Padlock Pouch

- Lockout kit for temporary maintenance and repairs
- Includes 2 padlocks, 2 hasps & 2 reuseable tags
- Pouch has D-shackles and belt loops



CODE	DESCRIPTION	UOM
SLK99290	Personal Padlock Pouch	Ea



Electrician's Mini Lockout Pouch

- Includes a combination of lockout devices for older style breakers and newer DINN style breakers
- Available with Safety Plus Lock or Compact Lock
- Supplied with lockout 'Danger' poly tags



CODE	DESCRIPTION	UOM
SLK848284	Electrician's Mini Lockout Pouch c/w Safety Plus Lock	Ea
SLK873848	Electrician's Mini Lockout Pouch c/w Compact Lock	Ea



Padlock Control Centre

- Durable padlock control centre to store and manage site padlock system
- Wall mountable steel cabinets
- Supplied with two keys
- Two sizes available, holding either 16 or 32 padlocks



CODE	DESCRIPTION	UOM
SLS851198	Padlock Control Centre Small	Ea
SLS851199	Padlock Control Centre Large	Ea



10 Lock Lockout Board

- Includes 10 padlocks, 4 hasps (25mm & 38mm) and 12 tags
- Board made from 4.7mm yellow acrylic - dimensions 343mm x 343mm



CODE	DESCRIPTION	UOM
SLS51187	10 Lock Board	Ea



BMP™ 21-PLUS Label Printer

- Perfect for organising your office, labelling electrical wires or datacomm cables, or even implementing a lean visual workplace
- Drop-lock-and-print materials
- Automatic label formatting
- Barcodes, serialisation and 104 symbols for electrical, safety and datacomm
- Print on materials up to 19.05mm wide
- Optional rechargeable Li-Ion battery (sold separately)



Use with:

Self-Laminating Vinyl Tape (B-427)

- UI recognised and RoHS compliant
- Ideal for marking data and electrical cables



Permasleeve® Wire Marker Sleeve Tape (B-342)

- UI recognised and RoHS compliant
- Full circle, 3-to-1 ratio heat shrink sleeves - excellent for insulation purposes

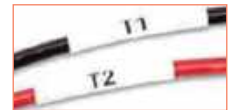

(Other tape options available - please contact your nearest SafetyQuip store for further details)

CODE	DESCRIPTION	UOM
SA139535	BMP™ 21-PLUS Printer	Ea



BMP™ 71 Label Printer

- Create on demand labels for multiple applications from one printer
- The large full colour graphical screen allows you to preview your label before printing
- The BMP™ 71 label maker can print on more than 30 different types of label materials
- Able to customise labels up to 50mm high
- Rechargeable battery and AC power adaptor included
- Supplied with hardcase, 1 roll of die cut labels, 1 ribbon cartridge, USB cable, Quickstart Guide and printer driver CD



Use with:

Durasleeve® Wiremarking (B-390)

- Long lasting and durable marking of wires and cables
- Consists of two parts: the marker insert (that is printed upon) and the vinyl carrier which the marker is inserted into
- Available in white or yellow, 15mm or 30mm length



(Other tape options available - please contact your nearest SafetyQuip store for further details)

CODE	DESCRIPTION	UOM
SA115158	BMP™ 71 Printer c/w LabelMark™ Software	Ea
SA872044	BMP™ 71 Printer c/w MarkWare™ Software	Ea

BAILEY

Ladderweld Access Platform - Temporary Work Platform

- Super strong 'fully welded' design fabricated from heavy duty aluminium
- Steel bracing under bottom tread and side bracing provides additional protection from impact damage
- Suited to 'high frequency' use, 170kg Industrial Rating
- 'Walk thru' design for stock picking and access to mezzanine floors, vehicle access and warehousing (no need to stock several products)
- Large 125mm wheels - improved portability and 'easy glide' action
- Large stable work platform (safe and stable) - 590mm x 800mm
- Manually operated braking system with HI VIS powder coated activation arm helps minimize unauthorised access
- Two safety gates fitted (a 2-in-1 product allowing for walk-thru access)

STEPS	PLATFORM HEIGHT	REACH HEIGHT	ALUMINIUM CODE
3	0.83m	2.8m	YLAAP13591
4	1.10m	3.1m	YLAAP13592
5	1.38m	3.4m	YLAAP13593
6	1.66m	3.7m	YLAAP13594
7	1.93m	3.9m	YLAAP13595
8	2.21m	4.2m	YLAAP13596
10	2.76m	4.8m	YLAAP13597
12	3.31m	5.3m	YLAAP13598
14	3.87m	5.9m	YLAAP13599



YLAAP13592



BAILEY Ladderweld MODULAR ACCESS SYSTEM

Modular Access Systems

Introducing the brand new Modular Access System that will revolutionise safe access to heights when used in conjunction with the Bailey Access Platforms. The modular components allow you to design and build an access platform that is customised to your needs.

- Modular system allows for unlimited types of configurations
- Fully welded frames and platforms with integrated toe boards
- Hand rails can be easily removed/repositioned to allow clear access to the work space
- Lockable castors allow easy repositioning of the system
- 170kg load rating per bay - Industrial duty - safe to use on a work site
- Meets standard AS 1892



1m bridge configuration



2m bridge configuration



Combination variable height 1m & 2m bridge configuration

INDUSTRIAL LADDERWELD 170KG

CODE	DESCRIPTION	SIZE	REACH HEIGHT
YLAAS13789	Modular Access System 1.0m Platform	1.0m	N/A
YLAAS13790	Modular Access System 2.0m Platform	2.0m	N/A
YLAAS13791	Modular Access System 3 Step Upright	0.83m	2.8m
YLAAS13792	Modular Access System 4 Step Upright	1.10m	3.1m
YLAAS13793	Modular Access System 5 Step Upright	1.38m	3.4m
YLAAS13794	Modular Access System 6 Step Upright	1.65m	3.6m

BAILEY



Tilt N Go

- Compatible with Bailey's Access Platforms
- Quick and easy to fit
- Ideal for rough terrain
- Can be used with or without existing wheel system

CODE	DESCRIPTION	UOM
YLAAP13817	Tilt N Go Castor	Ea



BAILEY

Professional Punchlock Platform Stepladders



YLAP13400

YLFP10722

- Punchlock® tread design increases the torsional rigidity of the overall ladder frame
- Industrial Duty Rated for work sites 170kg Aluminium/150kg Fibreglass where greater strength and safety is required
- Fibreglass Platform range Electro-Safe™ (non-conductive)
- Wide, anti-slip platform (490 x 400mm) for a secure work area
- 900mm handrail height from platform

DIMENSIONS			ALUMINIUM CODE	FIBREGLASS CODE
STEPS	PLATFORM HEIGHT	REACH HEIGHT		
2	0.58m	2.6m	YLAP13398	YLFP10720
3	0.86m	2.9m	YLAP13399	YLFP10721
4	1.15m	3.1m	YLAP13400	YLFP10722
5	1.43m	3.4m	YLAP13401	YLFP10723
6	1.72m	3.7m	YLAP13402	YLFP10724
7	2.0m	4.0m	YLAP13585	YLFP10725
8	2.23m	4.3m	YLAP13586	YLFP10726
Safety Gate			YLZ13647	YLZ13647

BAILEY

P170 Job Station Platform Stepladders



YLFP13531

YLAP13539

- Huge platform area (610 x 457mm) adds comfort and stability
- Multi-function handrail with optional 'DropLok' accessories
- Available in extra strong, heavy duty aluminium or fibreglass, 170kg Industrial Rating
- Large anti-slip feet for maximum stability and convenient carry handle
- Swivel castors for improved mobility

DIMENSIONS			ALUMINIUM CODE	FIBREGLASS CODE
STEPS	PLATFORM HEIGHT	REACH HEIGHT		
3	0.9m	2.87m	YLAP13538	YLFP13530
4	1.2m	3.16m	YLAP13539	YLFP13531
5	1.5m	3.45m	YLAP13540	YLFP13532
6	1.8m	3.74m	YLAP13541	YLFP13533
7	2.03m	4.03m	YLAP13542	YLFP13534
8	2.32m	4.32m	YLAP13543	YLFP13535
10	2.91m	4.91m	YLAP13544	YLFP13536
12	3.49m	5.49m	YLAP13545	YLFP13537
Safety Gate			YLZ13648	YLZ13648

BAILEY

P150 Platform Stepladders



YLFP13577

YLAP13581

- Lightweight and highly portable: up to 25% lighter than competitive products
- Fully functional 'magnetised' section on handrail secures tools and fasteners
- 150kg Industrial Duty Rating
- Available in extra strong, heavy duty aluminium or fibreglass construction



SAFETY GATE

DIMENSIONS			ALUMINIUM CODE	FIBREGLASS CODE
STEPS	PLATFORM HEIGHT	REACH HEIGHT		
3	0.9m	2.9m	YLAP13580	YLFP13576
4	1.2m	3.2m	YLAP13581	YLFP13577
5	1.5m	3.5m	YLAP13582	YLFP13578
6	1.8m	3.8m	YLAP13583	YLFP13579
Safety Gate			YLZ13647	YLZ13647
Castor Kit			YLZ13584	YLZ13584

All Bailey products are made to AS 1892.1

BAILEY

Stairway Ladder

- Slim profile for easy storage when not in use
- Wide and deep treads with anti-slip rubber insert for safety and stability
- Racked front frame for stair-like access
- 150kg Industrial Duty Rating
- Available with or without a folding handrail



YLA13747

YLA13751

CODE WITHOUT HANDRAIL	CODE WITH HANDRAIL	DESCRIPTION	SIZE	REACH HEIGHT
YLA13746	YLA13750	2 Step 150kg Ind.	0.45m	2.45m
YLA13747	YLA13751	3 Step 150kg Ind.	0.67m	2.67m
YLA13748	YLA13752	4 Step 150kg Ind.	0.89m	2.89m
YLA13749	YLA13753	5 Step 150kg Ind.	1.11m	3.11m

BAILEY

Double Sided Stepladder

- Punchlock tread design and deep fascia top cap increases the torsional rigidity of the overall ladder frame
- 150kg Industrial Duty Rating
- Double sided for greater versatility



YLA13386

YLF10484

ALUMINIUM CODE	FIBREGLASS CODE	DESCRIPTION	SIZE	REACH HEIGHT
YLA13385	YLF10483	DS3 150kg Ind.	0.9m	2.3m
YLA13386	YLF10484	DS4 150kg Ind.	1.2m	2.6m
YLA13388	YLF10485	DS6 150kg Ind.	1.8m	3.2m
	YLF10486	DS7 150kg Ind.	2.1m	3.5m
YLA13389	YLF10487	DS8 150kg Ind.	2.4m	3.8m
YLA13390	YLF10488	DS10 150kg Ind.	3.0m	4.4m
	YLF10489	DS12 150kg Ind.	3.6m	5.0m

BRADY

ToughStripe® Floor Marking Tapes & Die-Cut Shapes

- Made with Brady's B-514 polyester - withstands forklift traffic without tearing or lifting
- Low profile design minimises tears and scratches from skids, pallet jacks, etc.
- Ideal for marking aisles, passageways and storage locations
- The tape has a service temperature range of -17°C to 53°C



CODE	DESCRIPTION	UOM
STF872429	Toughstripe® Floor Tape 51mm x 30m - Black	Roll
STF872433	Toughstripe® Floor Tape 51mm x 30m - Blue	Roll
STF872434	Toughstripe® Floor Tape 51mm x 30m - Green	Roll
STF872435	Toughstripe® Floor Tape 51mm x 30m - Orange	Roll
STF872432	Toughstripe® Floor Tape 51mm x 30m - Red	Roll
STF872430	Toughstripe® Floor Tape 51mm x 30m - White	Roll
STF872431	Toughstripe® Floor Tape 51mm x 30m - Yellow	Roll
STF872438	Toughstripe® Floor Tape 51mm x 30m - Black/White	Roll
STF872436	Toughstripe® Floor Tape 51mm x 30m - Black/Yellow	Roll
STF872437	Toughstripe® Floor Tape 51mm x 30m - Red/White	Roll
STF872449	Toughstripe® Floor Tape 51mm x 30m - Yellow Dash	Roll



CODE	DESCRIPTION	UOM
STF873235	Toughstripe® Foot Prints (L/R) 254 x 89mm - Green	Pk/10
STF873234	Toughstripe® Foot Prints (L/R) 254 x 89mm - Red	Pk/10
STF873239	Toughstripe® Foot Prints (L/R) 254 x 89mm - White	Pk/10
STF873237	Toughstripe® Foot Prints (L/R) 254 x 89mm - Yellow	Pk/10
STF873229	Toughstripe® Dot Shapes 89mm - Green	Roll/350
STF873228	Toughstripe® Dot Shapes 89mm - Red	Roll/350
STF873233	Toughstripe® Dot Shapes 89mm - White	Roll/350
STF873231	Toughstripe® Dot Shapes 89mm - Yellow	Roll/350
STF873247	Toughstripe® Arrow Shapes 76 x 203mm - Green	Pk/10
STF873246	Toughstripe® Arrow Shapes 76 x 203mm - Red	Pk/10
STF873249	Toughstripe® Arrow Shapes 76 x 203mm - Yellow	Pk/10

PRO

PRO CHOICE SAFETY GEAR

Self-Adhesive Floor Tapes

- Heavy duty hazard tapes for floors and other surfaces
- HI VIS reflective options
- Slip resistant 'sand paper grip' option for wet areas



CODE	DESCRIPTION	UOM
STF3075SA	Self Adhesive Tape Yellow/Black 30m x 75mm	Roll
STF5050R:BY	Self Adhesive Reflective Tape Yellow/Black 50m x 50mm	Roll
STF5050R:RW	Self Adhesive Reflective Tape Red/White 50m x 50mm	Roll
STF1850NS:BY	Self Adhesive Non-slip Tape Yellow/Black 18m x 50mm	Roll

BRADY

Indoor Warning Tapes

- For identification of hazardous areas or work stations
- Can be used on floors, stairways, hazardous objects etc.
- Durable vinyl adhesive backed tape for industrial conditions
- Also available in a range of other sizes and in outdoor and reflective materials



CODE	DESCRIPTION	UOM
STF55297	Indoor Warning Tape 75mm x 16.4m - Red/White Stripe	Roll
STF55303	Indoor Warning Tape 75mm x 16.4m - Black/Yellow Stripe	Roll
STF76319	Indoor Warning Tape 75mm x 16.4m - Black/Yellow Check	Roll
STF55293	Indoor Warning Tape 75mm x 16.4m - Black/White Stripe	Roll
STF76318	Indoor Warning Tape 75mm x 16.4m - Black/White Check	Roll
STF850653	Indoor Warning Tape 75mm x 16.4m - Green/White Stripe	Roll



Professional Marking Products

Line Marking Paint 500g

- Quick drying
- Ideal for car parks, factories, warehouses and sporting grounds
- Use with the Dy-Mark Line Master Line Marking Machine



Spray & Mark 350g

- Highly visible marks
- Ideal for use on concrete, bitumen, steel & timber
- Available in a large range of colours

CODE	DESCRIPTION	UOM
STP150	Line Marking Paint - Various Colours*	Ea
STP400635	Spray & Mark Paint - Various Colours*	Ea
STLM00203	Line Master 4-Wheel Line Marker	Ea



Stencils

- Reusable poly stencils, ideal for marking and warning of hazards



WIDE RANGE AVAILABLE



CODE	DESCRIPTION	UOM
STSP	Floor Stencil Poly 600 x 450mm	Ea
STSN	Floor Stencil Numbers 0-9 100mm	Set
STSL	Floor Stencil Letters A-Z 100mm	Ea

*Please note: Age restriction may apply to the sale/purchase of this product



Air Grid Non-Slip Anti-Fatigue Mat

- Extremely comfortable - provides relief from constant standing
- Leather grain pattern on surface eliminates trips and slips on mat
- Spilt liquids drain from mat surface along channels and out holes to keep mat surface continually dry
- Suction cups on underside assist in steady floor adhesion
- Yellow border option ensures mat stands out
- Grease proof - will not deteriorate in greasy conditions
- HACCP Certified

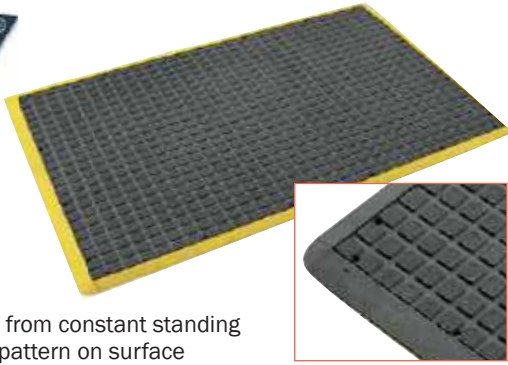

CODE	DESCRIPTION	UOM
YMAG23B	Air Grid 600mm x 900mm - Black/Black Edge	Ea
YMAG23Y	Air Grid 600mm x 900mm - Black/Yellow Edge	Ea
YMATAG34B	Air Grid 900mm x 1200mm - Black/Black Edge	Ea
YMATAG34Y	Air Grid 900mm x 1200mm - Black/Yellow Edge	Ea



Comfort Link Modular Safety Mat

- Rubber mat tiles, link together to form a desired shape or size
- Non slip surface
- Soft formula provides relief from constant standing
- Beveled edges and corners available in yellow
- Available in holed (wet areas), solid (dry areas), grease proof holed or grit top holed options
- Used in manufacturing and production areas, workbenches and workstations etc.

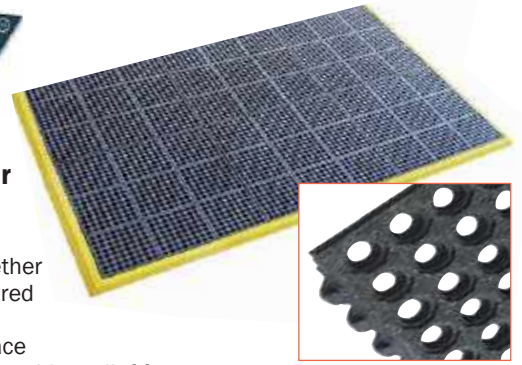

CODE	DESCRIPTION	UOM
YMATTE	Comfort Link General Purpose 900mm x 900mm - Black	Ea
YMATTEG	Comfort Link Grease Proof 900mm x 900mm - Terracotta	Ea
YMATTEE	Comfort Link Edging 900mm x 75mm - Yellow	Ea



Rubber Brush Scraper Outdoor Commercial Entrance Mat

- Heavy duty rubber mat for medium traffic entrances
- Studs on mat surface dislodge dirt and mud from the bottom of shoes
- Easy to clean: simply hose out
- Beveled edges for added safety
- Slip resistant backing keeps mat steady on the floor

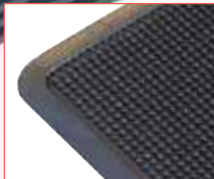
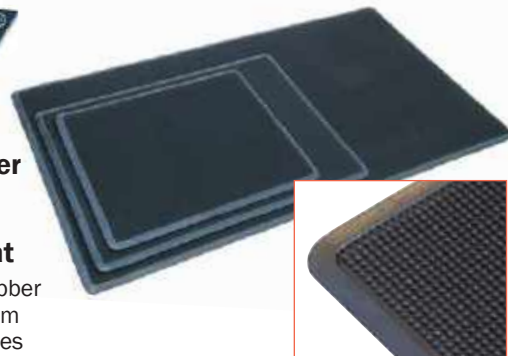

CODE	DESCRIPTION	UOM
YMATRBB	Brush Scraper 610mm x 810mm - Black	Ea
YMATRBM	Brush Scraper 710mm x 1070mm - Black	Ea
YMATRBL	Brush Scraper 910mm x 1830mm - Black	Ea



Safety Cushion Dry/Wet Area Safety Mat

- Comfortable, anti-slip rubber mat for wet or dry areas
- Beveled edges for safety
- Soft formula provides relief from constant standing
- Honeycomb surface gives excellent traction
- Optional grease proof formula (terracotta colour)
- Used in bars, kitchens, at workbenches and workstations etc.

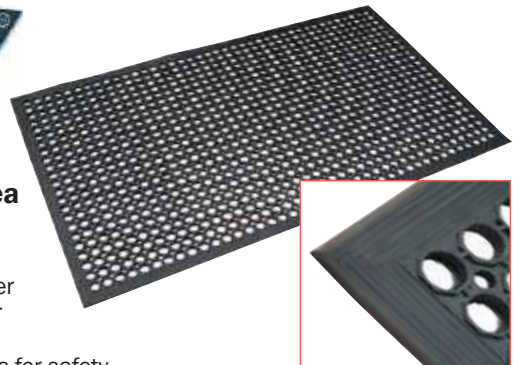

CODE	DESCRIPTION	UOM
YMATCLS	Safety Cushion General Purpose 600 x 900mm - Black	Ea
YMATCLG	Safety Cushion Grease Proof 600 x 900mm - Terracotta	Ea
YMATCLN	Safety Cushion General Purpose 900 x 1500mm - Black	Ea
YMATCLR	Safety Cushion Grease Proof 900 x 1500mm - Terracotta	Ea



Utility Matting Dry/Wet Area Safety Matting

- Versatile rubber matting on a roll
- Soft formula provides relief from constant standing
- Non-slip surface provides traction
- Easy to cut to length or width and shape
- Large drainage holes allow the escape of spilt liquids
- Used in bars, kitchens, showers and wash-up areas and also in the backs of utes and vans

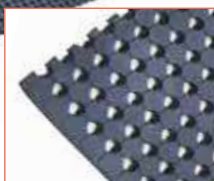
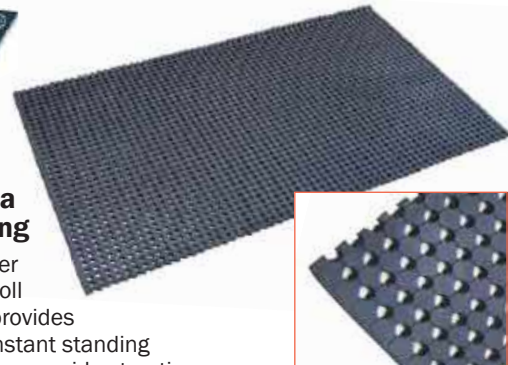

CODE	DESCRIPTION	UOM
YMATUM900	Utility Matting 900mm Wide	Per Metre
YMATUM1800	Utility Matting 1800mm Wide	Per Metre



Ribbed Indoor Commercial Entrance Mat

- PVC backed polypropylene mat for medium traffic entrances
- Coarse, bi-level fibres scrape footwear clean
- Absorbent surface dries feet effectively
- Easy to clean: can be hosed, swept or vacuumed out
- Available in a range of colours



CODE	DESCRIPTION	UOM
YMATRM23	Ribbed Mat 600mm x 900mm	Ea
YMATRM35	Ribbed Mat 900mm x 1500mm	Ea
YMATRM46	Ribbed Mat 1200mm x 1800mm	Ea

EcoBlast

Rechargeable Signal Air Horn

- Ready to emit a powerful 120dB signal
- Aluminium alloy body
- Refill valve allows recharge using a MiniAir pump, bicycle air pump or air compressor
- Available with or without MiniAir pump



CODE	DESCRIPTION	UOM
MM101	EcoBlast Signal Air Horn	Ea
MM102	EcoBlast Alloy Signal Air Horn c/w MiniAir Pump	Ea

EcoBlast

PRO Heavy Duty Air Horn

- Suitable for most industrial workplaces
- Impact resistance plastic - all-weather application
- Up to 150 blasts per charge
- Rechargeable via any source of compressed air - no need for replacement cartridges
- Included pressure gauge, carry handle and shoulder strap



CODE	DESCRIPTION	UOM
MM500	EcoBlast Pro Air Horn	Ea



Acoustic Air Horn

- Hand held and operated air horn
- Environmentally friendly canister - does not contain any harmful gas
- Refills and plastic bracket also available



CODE	DESCRIPTION	UOM
MM001	Trem Horn & Canister	Ea
MM002	Trem Horn Canister Refill	Ea

Megaphones With Siren

- Compact ABS hand held 10W output
- Range: 250m for MM180035, up to 500m for MM180040
- Operates on six AA batteries (not included)



CODE	DESCRIPTION	UOM
MM180035	Megaphone with Siren Hand Held Type, Red, 13-17hrs Speak Time	Ea
MM180040	Compact Power Megaphone with Siren, White, 8hrs Speak Time	Ea

MM180035



Portable Access Steps

- c/w Anti-Slip Tape

Step-Up® Team Step

- 370mm x 370mm deck size
- 370mm deck height
- Rubber feet

Jumbo Team Step®

- 380mm dia. deck size
- 360mm deck height
- Springloaded castors

Monstar Step

- 370mm x 370mm deck size
- 375mm deck height



CODE	DESCRIPTION	CAPACITY	WEIGHT	COLOURS	UOM
YLPST200	Step-Up® Access Step	180kg	5.0kg	Yellow, Orange	Ea
YLPST300	Jumbo Team Step®	150kg	5.0kg	Yellow	Ea
YLPST400	Monstar Step	180kg	3.5kg	Yellow	Ea



Forklift Safety Cage

- Flat pack design for easy transport and storage
- Designed to carry two people or 250kgs
- Dimensions: 1.2m x 1.2m x 1.09m with 2.2m safety screen
- Meets AS 2359.1



CODE	DESCRIPTION	UOM
MFC	Forklift Safety Cage	Ea



FRP Anti-Slip Stair Nosing & Panels

- Fibreglass composite with integrated anti-slip grit
- Industrial grade: won't chip or delaminate
- Highly resistant to chemical attack
- Safety yellow final resin layer
- No steel to rust or corrode
- Available in a wide range of sizes



STAIR NOSING

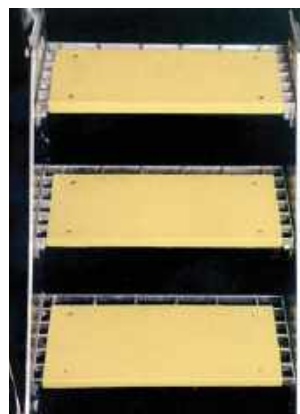

STAIR NOSING



FLOOR PLATE

CODE	DESCRIPTION	UOM
YASN75076	FRP Stair Nosing 750mm x 76mm x 30mm	Ea
YASN90076	FRP Stair Nosing 900mm x 76mm x 30mm	Ea
YASN120076	FRP Stair Nosing 1200mm x 76mm x 30mm	Ea
YASP600200	FRP Floor Plate 600mm x 200mm	Ea
YASP900200	FRP Floor Plate 900mm x 200mm	Ea

A

Absorbents	122, 123, 124
Access platforms/systems	136
Aerosol storage	127
Air horns	140
Anchorage devices	93, 95, 97
Anchor straps	92, 94, 96, 97
Anti-slip panels	140
Aprons	61, 65
ARC flash clothing	57

B

Bags	66
Backpacks	66
Back supports	65
Barrier chain	118
Barrier creams	88
Barrier mesh	115
Barriers	116, 117
Beacons	115, 118, 119
Beanies	63
Body cooling apparel	63, 107
Bollards	115, 116
Boot brush	76
Boot cleaning accessories	72, 76
Boot covers	76
Boot dip mat	76
Bowyangs	76
Breathalysers	105
Bump caps	8
Bunting flags	118

C

Cable clips	129
Cable protectors	129
Caps, disposable	61, 62
Cap light	120
Caps, safety & accessories	6, 7, 8, 10
Cigarette receptacle	131
Cleaners	110
Clothing, chainsaw	59
Clothing, cooling	63, 107
Clothing, disposable	60, 61, 62
Clothing, freezer	63
Clothing, welding	64, 65
Cleaners, wipes	110
Cleaners, industrial	110
Confined space equipm.	37, 93, 95, 96
Cooling apparel	63, 107
Corrosive storage	126, 127
Creams, skin	88, 109
Cylinder restraints	128, 131
Cylinder storage	127, 128

D

Dangerous goods storage	125-128
Deluge systems	132, 133

Defibrillators	105
Disinfectants	104, 110
Disposable clothing	60, 61, 62
Disposable respirators	28, 29
Document storage	125, 128
Drink coolers/bottles	106, 107
Drop tool prevention	98, 99, 100
Drug testing kits	105

E

Earmuffs	22, 23, 24, 25
Earmuffs, electronic	23, 25
Earplug dispensers	20, 21, 22
Earplugs	20, 21, 22
Electrical, powerboard	129
Electrical, leads	129
Electrician's gloves	87
Electrolyte replacements	106, 107
Escape & rescue kits	96
Eye and face wash	103, 132, 133
Eyewear accessories	18
Eyewear, safety	12-18
Eyewear, welding	18



F

Face shields	17, 22, 57
Fencing, barrier	115, 117
Fire resistant apparel	56, 57
Fire blankets	131
Fire extinguishers	130
Fire protection equipment	130, 131
First aid	102, 103, 104
First aid, signage	103
Flags	118
Flammable storage	125, 126, 127, 128
Floor, stands	138
Floor, stencils	138
Floor, tapes & marking	138
Footwear, disposable	60, 61
Footwear, leather	68-75
Footwear, PVC	75
Forklift cage	140

Freezer wear	63
--------------	----

G

Gas cylinder storage	127, 128
Gas detectors	38
Gloves, anti-vibration	78, 80, 81, 82
Gloves, chainsaw	59
Gloves, chemical	85
Glove clips	88
Gloves, cotton/poly	87
Gloves, cut resistant	78, 79
Glove, dispenser	88
Gloves, disposable	85, 86
Gloves, electrician's	87
Gloves, heat protection	78, 87
Gloves, latex	83, 85, 86, 87
Gloves, leather	81, 87
Gloves, mechanic's	80, 81
Gloves, nitrile	80, 82, 83, 85, 86
Gloves, PU/PVC	82, 84, 85
Gloves, cold workers	80, 82
Gloves, welding	87
Goggles	16, 18, 28
Gumboots	75

H

Hats	9, 10
Hand cleaners	108
Hand sanitisers	104
Harness accessories	94
Harnesses	91, 92, 94, 96, 97
HAZCHEM signage	128
Headlamps	120
Headwear, soft	9, 10
Headwear, sun protective	9, 10
Helmets, bushfire	8
Hard hats, decals	10
Hard hats	6, 7, 8
Hoist & tripod systems	93, 95, 96
Hoods	64, 65
Hydration, backpacks	107
Hydration, drinks	106, 107

I

Insect repellent	109
Insoles	70, 72

J

Jackets	44, 48, 50-52
Jackets, waterproof/resistant	48-53, 56
Jackets, HI VIS	48-53, 56
Jeans	42
Jumpers	46, 53

K

Karabiners	93
Kerb ramps	116
Knee pads	65
Knives, safety	88

PRODUCT INDEX

L			
Ladders	136, 137		
Lanyards	93, 95-98, 100		
Lead stands	129		
Lifelines	93, 95		
L			
Lifting & rigging	100		
Lighting & torches	120		
Lights, safety cap	120		
Lights, traffic	115, 118, 119		
Line marking	138		
Lockout tagout	134, 135		
Logo hard hats	6, 7		
Lumberjack cap/visor/muff	8		
M			
Matting	139		
Megaphones	140		
Mirrors	121		
O			
Overalls	43, 56		
Overalls, chemical	60, 61, 62		
Overalls, disposable	60, 61, 62		
P			
Painter's workwear	46		
Pedestrian management	114, 117, 118		
Personal lights	120		
Pesticide + herbicide storage	126		
Pipe markers	128		
Pole straps	92, 94, 97		
Printers, label	135		
Puncture resistant gloves	79		
R			
Rainwear	50		
Ratchet tie downs	100		
Rehydration drinks	106, 107		
Rescue products, height	91, 93, 95, 96		
Respirators, airline	36, 37		
Respirators, disposable	28, 29, 60		
Respirators, escape	37		
Respirators, full face	30, 31, 33		
Respirators, half mask	30, 31, 32		
Respirators, PAPR	34, 35, 36, 37		
Respirators, SCBA	37		
Respiratory, airline filters	37		
Respiratory, airline hose	37		
Rigging blocks/hoists	100		
Road traffic signage	114, 115		
S			
Sanitary	110		
Sharps containers	103		
Shirts, workwear	40, 41, 44-47, 56, 57		
Shirts, polo	46, 54		
Shoe/boot covers, disposable	60, 61		
Shorts, workwear	43 - 47		
Shower stations	132, 133		
Signage	112-115, 128, 131		
Sleeves, cut resistant	66		
Sleeves, disposable	61, 62		
Slings	100		
Snake bite, first aid kit	103		
Snake bite gaiters	65		
Socks	76		
Spectacle, accessories	18		
Spectacle, cleaning	18		
Spectacles, safety	12-15, 18		
Speed humps	116		
Spill bunds	124		
Spill control	122-125		
Spill kits	122, 123		
Steps	140		
Storage box - documents	125, 128		
Storage cans	125		
Sunscreens	109		
Swing signs	114		
T			
Tapes, barricade	118		
Tapes, floor	138		
Tapes & labelling - hard hats	6		
Tapes, vehicle	119		
Tether bars	97		
Tool tethering	98, 99, 100		
Torches	120		
Traffic cones	115		
Traffic cone bar	115		
Traffic cone lights	115		
Traffic control/signage	114, 115		
Traffic lights	118, 119		
Traffic wands	118		
Tripods & winches	93, 95, 96		
Trousers, workwear	42, 44-46, 56, 57		
V			
Vehicle lights	119		
Vehicle tapes	119		
Vehicle warning triangles	119		
Vehicle whip aerials	119		
Vests, HI VIS	58		
Visors	6, 7, 17		
Visors - arc flash	57		
Visor holder	6, 7		
W			
Washroom hand cleaners	108		
Welding/heat apparel	64, 65		
Welding hoods	64, 65		
Welding screens	64		
Wet weather clothing	48-52, 56		
Wheel stops	116		
Wipes, cleaning	110		
Wipes, PPE	18		
Women's workwear	47		
Workwear	40-47		
Workwear, flame resistant	56, 57		

We come to YOU!



THE SAFETYQUIP RISK INDEX

SafetyQuip has created a risk index for nationally ranged products. These products have been classified with a letter and a number as per the table below. The risk index code and commentary for these products will be highlighted on each invoice.

RISK	USE RISK	SOURCE AVAILABLE INFORMATION	CONSIDERATION OF ALL APPLICATION FACTS NECESSARY	WARNING NOTES MAY APPLY	SEEK ADVICE FOR TOTAL PROTECTION	DO NOT USE WITHOUT TRAINING & KNOWLEDGE
E	MINIMAL	1	1	2	2	3
D	POSSIBLE	1	1	2	3	4
C	MODERATE	1	2	3	4	4
B	HIGH	2	3	4	4	5
A	VERY HIGH	3	4	4	5	5

RISK MANAGEMENT

Control of risk is central to working safely with hazardous substances and workplace applications.

The steps in a risk assessment system are:

1. Identify the hazard.
2. Analyse how and why the hazard could occur.
3. Analyse the consequence of the hazard.
4. Consider the likelihood of the hazard and estimate the risk.
5. Judge risk acceptability using a matrix or tie line system to calculate a risk score.
6. Decide upon and select risk controls.
7. Monitor the risk controls put in place.



DISCLAIMER: The information detailed above is not provided as a solution to the control of workplace hazards. It is an outline and has not been prepared as any statement of law nor is it intended to replace or substitute for professional and/or legal advice which is strongly recommended.

Support for the Community



SafetyQuip has been a proud supporter of the **Australian Men's Shed Association (AMSA)** since 2011 when \$5000 was donated to AMSA for the development of an operations manual for local Men's Sheds. In the same year SafetyQuip also supported AMSA by serving as a sponsor and trade exhibitor at the 4th National Men's Shed Conference in Brisbane.

Men's Sheds are community-based, non-profit, non-commercial organizations that are accessible to all men and whose primary activity is the provision of a safe and friendly environment where men are able to work on meaningful projects at their own pace in their own time in the company of other men. A major objective is to advance the well-being and health of their male members.

The AMSA through the Men's Shed movement continues to develop initiatives and programs that address men's health and wellbeing from the perspective that many Aussie men are not very good at looking after themselves physically or emotionally.

To help to address this situation the Australian Men's Shed Association has put together a men friendly health screening and information project called **"Spanner in the Works?"**. The program has the following main aims:

- Provide some basic health screening and advice to men, utilising the staff resources of the local health service within the "men friendly" environment of the Men's Shed
- Referral on of men to health professionals (as appropriate)
- Provide "men friendly" health information and health awareness through the "Spanner in the Works?" booklet
- Have local men and shedders engage with their local health service providers
- Have local men (non 'shedders') engage with their local Men's Shed
- Have local health service providers and local Men's Shed engage with each other

In recognising the potential of the "Spanner in the Works" program to have a real impact on men's health issues, SafetyQuip provided a \$10,000 sponsorship to assist in promoting the program to all Men's Sheds throughout Australia. Ask for a copy of the **pocket guide** or visit the AMSA website **www.mensshed.org**

SafetyQuip is honoured to support the vital community work undertaken by the Australian Men's Shed Association.



'Spanner in the Works?' pocket guide ►



Are You Man Enough?

Breast cancer doesn't strike only women. Cancer Australia estimates that in 2019, 19,000+ women and 164 men will be diagnosed, and that the disease will claim the lives of 3,000+ women and 32 men.



Bisley and SafetyQuip are taking a stand in the fight against breast cancer.

Bisley has created a special 'Real Men Wear Pink' range of workwear and will donate \$3 from the sale of each promotional garment with the aim of raising \$2million research dollars focusing on breast cancer prevention. SafetyQuip is proud to be a part of this effort by offering the following 'Real Men Wear Pink' range in our catalogue. Both mens and ladies styles are available.



*Garments come complete with NBCF embroidery on sleeve

Product Code	Description	Page
WBS6896TP	Mens Taped Two-Tone Shirt*	40
WBS6696TP	Mens Taped Two-Tone Shirt*	40
WBSL6896TP	Ladies Taped Two-Tone Shirt*	47

To find out more about how you can be a part of this life-saving effort in the fight against breast cancer, visit nbcf.org.au/real-men-wear-pink.

Care for the Environment

The paper used in printing this catalogue originates from legal and sustainable sources certified under the Programme for the Endorsement of Forest Certification (PEFC).



DISCLAIMER: Whilst every care and attention to detail has been taken in the presentation of products in this catalogue, SafetyQuip Australia Pty Ltd accepts no responsibility for manufacturers changes and/or amendments to product specifications displayed in the catalogue and reserves the right to supply these changed products as necessary. Not all products displayed herein are stock items and may be subject to order.

COPYRIGHT © SAFETYQUIP AUSTRALIA PTY LTD 2020. SafetyQuip Australia retains copyright in this catalogue. No part of this catalogue may be reproduced by any process, electronic or otherwise without the specific written authority of SafetyQuip Australia Pty Ltd.





The Store That Comes To You



**Proudly Australian
Owned & Operated**

**Connect with SafetyQuip on
your favourite social channel:**

 [company/safetyquip-australia-p-l](https://www.linkedin.com/company/safetyquip-australia-p-l)

 [SafetyQuip](https://www.youtube.com/SafetyQuip)

 [@SafetyQuipAustralia](https://www.facebook.com/SafetyQuipAustralia)

FOR PRODUCT AND SERVICE ENQUIRIES...

NEW SOUTH WALES

NSW North East

2/81 Barnes Street
TAMWORTH NSW 2340
Ph: 02 6762 1333
tamworth@safetyquip.com.au

Hunter Valley

1/43 Elwell Close
BERESFIELD NSW 2322
Ph: 02 4966 1102
hunter@safetyquip.com.au

Central Coast

3/305 Manns Road
WEST GOSFORD NSW 2250
Ph: 02 4322 4179
central.coast@safetyquip.com.au

VICTORIA

Melbourne East

417 Dorset Road
BAYSWATER VIC 3153
Ph: 03 8740 1234
bayswater@safetyquip.com.au

Melbourne North

1/108 Bell Street
PRESTON VIC 3072
Ph: 03 9484 2299
preston@safetyquip.com.au

QUEENSLAND

Brisbane North

1/420 Newman Road
GEEBUNG QLD 4034
Ph: 07 3216 5844
brisbane.north@safetyquip.com.au

Brisbane West

2/56 Boundary Road
ROCKLEA QLD 4106
Ph: 07 3274 1200
brisbane.west@safetyquip.com.au

Sunshine Coast

615 Old Maroochydore Road
KUNDA PARK QLD 4556
Ph: 07 5450 1424
sunshine.coast@safetyquip.com.au

WESTERN AUSTRALIA

Perth North

1/39 Erindale Road
BALCATTWA WA 6021
Ph: 08 9446 1532
perth.north@safetyquip.com.au

SOUTH AUSTRALIA

Adelaide

100-102 Cavan Road
DRY CREEK SA 5094
Ph: 08 8349 6988
adelaide.north@safetyquip.com.au



LOCAL KNOWLEDGE  SAFER WORKERS

www.safetyquip.com.au